

Most - Often - Needed

1954

VOLUME 14

RADIO
DIAGRAMS

and Servicing Information

Compiled by

M. N. BEITMAN



SUPREME PUBLICATIONS

MANUAL OF 1954 MOST-OFTEN-NEEDED RADIO DIAGRAMS

Index

Admiral Corp.

4B2	5
4B21	5
4B22	5
4B24	5
4B28	5
4B29	5
5F31, -A, -B	6
5F32, -A, -B	6
5F33, -A, -B	6
5F34B	6
5F38, -A, -B	6
5G3	7
5G31	7-8
5G32	7-8
5G33	7-8

Arvin Industries

RE-333	14-15
RE-342	9
RE-347	11
RE-348	12
RE-350	10
RE-352	13
581	14-15
741T	13
746P	11
747P	11
753T	12
758T	10
760T	9
780TFM	14-15

Bendix

M-4	16
M-4A, -B	16
753F, -M, -W	18
853A to -D	17
953A to -D	17

Buick

981550	127-128
981551	129-130

Cadillac

7264165	135-136
7264185	135-136
7264195	135

Capehart-

<u>Farnsworth</u>	
T-54	19
CR-79	20
CR-130	19
CR-147	20

Capehart, cont.

RP-153	20
RP-254	20

CBS-Columbia

4P1	22
5C1	21
515-1	21
535	22
5165	21
5220	22
5330	21

Coronado, see

Gamble-Skogmo

Crosley Corp.

25F	23
F-25BE, -BK	23
F-25GN, -MN	23
115F	25-26
F-115GN	25-26
F-115MN	25-26
F-115TN	25-26
120F	24
F-120BN	24

Delco, see

United Motors

DeWald Radio

G-408	27
H-527	27
H-528	28
H-533	28

Emerson Radio

745B	29
746B	30-31
747	32
754D	29
778B	34
783B	33
788B	36
789B	35
790B	37
805B	38
806	35
807	35
120147B	37
120176B	29
120177B	30-31
120178	32
120199B	34
120200B	33
120201B	36
120202D	38
120207B	35

Gamble-Skogmo

RA33-9856D	142
35RA37-43-8355	39
35RA40-43-8247A	40
RA37-43-9855	141
RA42-9850A	41

General-Electric

424	42
425	42
431, -A	43
431B, -BH	43
432, -A, -B	43
433B	43
440	44-45
442	43
443	43
444	43
450	42
451	42
452	42
555	46-47
556	46-47
557	48
558	48
559	48
560	48
561	48
564	48
565	48
566	48
572 to 575	49
620 to 622	51
625	50
626	50
630 to 632	54
640	52-53
641	52-53

Hallcrafters

TW-25	55
51C1, -A	56
51C2, -A	56
611	57-58
612	57-58

Montgomery-Ward

25BR-1542A	59
25GSL-1072A	60
25GSL-1560A	61
25GSL-1561A	61

Motorola, Inc.

CT2A6	64
CT2M6	65

Motorola, cont.

GMT2M6	65
HN2A6	64
HN2M6	65
OE2A6	64
OE2M6	65
PC2A6	64
PC2M6	65
SR2A6	64
SR2M6	65
BK3A6	64
BK3M6	65
CTA3	62
GMT3A6	64
GMT3M6	65
HJ3A6	64
HJ3M6	65
HN3A6	64
HM3M6	65
HT3A6	64
HT3M6	65
KR3A6	64
KR3M6	65
PD3A6	64
PD3M6	65
SR3A6	64
SR3M6	65
R14M6	65
R15A6	64
R16M6	63
R17A6	63
53C1	67-68
53C2	67-68
53C3	67-68
53C4	67-68
53C6	70
53C7	70
53C8	70
53C9	70
53D1	69
53R1, -U	71
53R2, -U	71
53R3, -U	71
53R4, -U	71
53R5, -U	71
53R6, -U	71
53X1	72
53X2	72
53X3	72
53X4	72
54L1 to 54L6	66
63C1	73
63C2	73
63C3	73
63LSS	74
63X1, -A	75

MANUAL OF 1954 MOST-OFTEN-NEEDED RADIO DIAGRAMS

Motorola, cont.

63X2	75
63X3	75
HS-335	75
HS-336	72
HS-338	70
HS-359	69
HS-366	67-68
HS-384	71
HS-397	73
404	76
HS-414	66
HS-415	74
HS-426	71
504	77
612	78
829	79-80

Oldsmobile

983090	131-132
983091	133-134

Olympic Radio

445	81
449	82

Packard-Bell

531 to 533	83
631	84

Philco Corp.

B569	86
B570	86
B572	86
B574	87
B578	87
B649	88
B650	88
B710	86
B711	86
B712	87
B712X	86
B714	87
B1349	89-90
B1352	89-90
B1750	89
B1752	89
B1753	89

RCA Victor

3-BX-671	92-93
3-BX-672	92-93
3-HES-5	91
3-HES-5A	91
4-X-641	94
RS-146,-X	91
RP-197-1	95-102
RC-1125	92-93
RC-1140	94

Sears, Roebuck

3004	103
3005	103
3006	103
3007	104
3008	104
3009	104
3040	105
3045	105
3046	105
3215	106
3217	106
3218	106
757.120	104
757.130	103
528.253	105
528.254	105
528.265	106

Sentinel Radio

1U-345P	108
1U-352	107
1U-355P	109
1U-356	110
352	107
356	110

Sparton

5A3, 5A3C	112
6L3	111
230	112
232	112
239	112
311C	112
312C	112
315C	112
319C	112
350, 351	111
1300	111
1301	111

Stewart-Warner

9170-B,C,D	113
9175-B,-BU	114
9175-G,-GU	114
9175-H,-HU	114
9180-B,-H	115
9181-A,-C	116
9181-D,E,F	116
9182-C,H,J	116
9186-A,-B	116
9187-E,-J	116

Stromberg-Carlson

HFT	117
HI FI ET	117
BP-1	118
HFP-1	117

Sylvania Elect.

1-601-4	119
1-601-5	119

Sylvania, cont.

1-603-1	120
1-603-2	120-121
1-606-1	122
454	122
568	119
5184	119

Tele-King Corp.

RKC-54	126
--------	-----

Trav-ler Radio

5091	123
5180A,B,M	123
5182B,-M	124
5305	124
5356	125
9051	125
9052	125
9060	125
9061	125

Truetone, see

Western Auto

United Motors

981550	127-128
981551	129-130
983090	131-132
983091	133-134
7264165	135
7264185	135
7264195	135

Western Auto

4CL4	143
D-2386	137
D-2387	137
D-2388	137
D-2389	137
D-2410A	138
D-2411A	138
D-2412A	138
D-2413A	138
D-2418	139
D-2419	139
D-2420	139
D-2585	143
D-3300	140
D-3351	141
D-3352	141
D-3353	141
D-3465A	142
D-4320B	144

Westinghouse EL

H-377	150
H-391T5	147
H-392T5	147
H-394T5	147
H-397T5	149
H-398T5	149

Westinghouse +

H-404T5	147
H-405P5	146
H-406P5	146
H-409P4	150
H-410P4	150
H-411P4	150
H-414P4	148
H-415P4	148
H-417T5	152
H-418T5	152
H-420T5	147
H-421T5	147
H-422P4	151
H-423P4	151
H-424P4	151
H-425P4	151
H-434T5	145
H-435T5	145
H-436T5	145
H-437T5	145
H-438T5	145
H-461P4	148
H-462P4	148
H-463P4	148
H-464P4	148
H-479P4	148
V-2156-2	146
V-2157-13	147
V-2157-14	147
V-2182-2	148
V-2184-2	149
V-2185-1	150
V-2186-1	152
V-2188-1	151
V-2189-2	145

Zenith Radio

3L-01	154
3M-02	153
4L-03	156
5L-06	155
5L-07	155
5L-08	157
5L-09	157
5M-02	158
6L-20	159
10L-20	160
HF14, HF14E	153
HF15E, -R	153
M-510G, -R	158
M-510W, -Y	158
L-515	155
L-520	155
L-565E, -R	157
L-566	157
L-677E, -R	159
L1083E	160
L1086R	160
L2281	156
S-9011	154
S-9012	154

MANUAL OF 1954 MOST-OFTEN-NEEDED RADIO DIAGRAMS

Admiral

CHASSIS 482
MODELS 4821, 4822, 4824, 482B, 4829

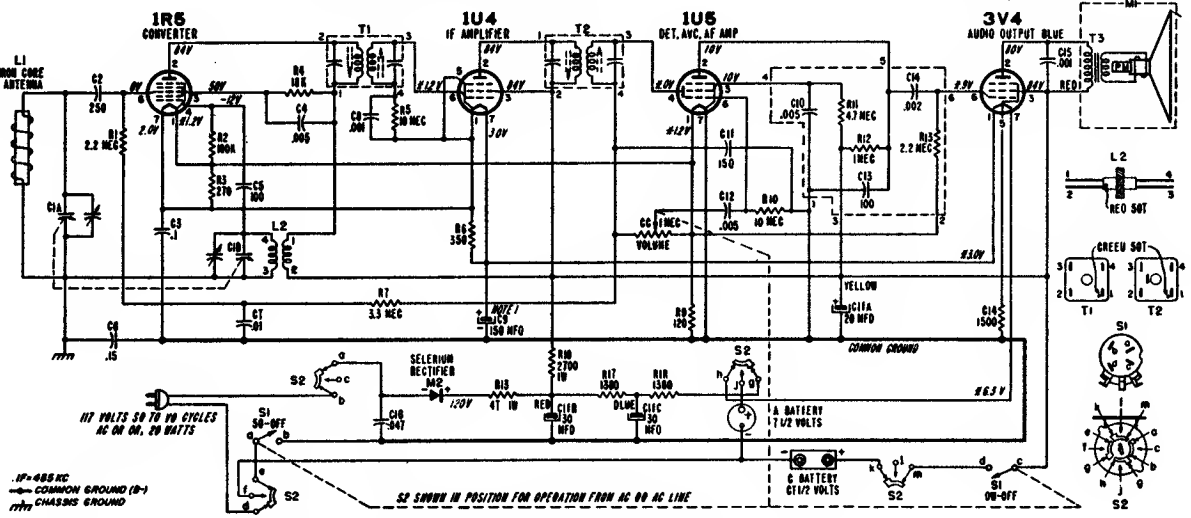

VOLTAGE DATA

Voltages shown on schematic diagram.

All readings made between tube socket terminals and B minus (terminal of On-Off switch).

Measured on 117 Volt AC line.

Volume control minimum; dial set at low frequency end.

Voltages measured with vacuum-tube voltmeter.

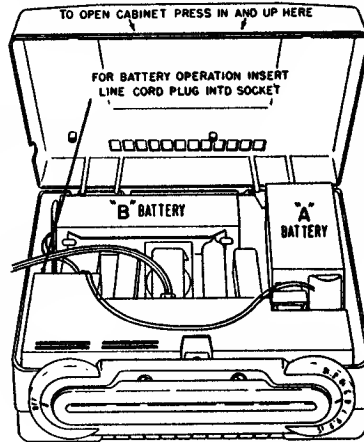

Disconnect the AC line cord from the wall outlet. Squeeze the handle support springs together near the escutcheon to remove the plastic handle. Remove the two escutcheon mounting screws. Remove the "Off-Volume" and "Tuning" knobs. Now open the cabinet (see illustration at left). Loosen the speaker mounting clips, rotate them away from the speaker, and carefully lift the chassis and batteries out of the cabinet.

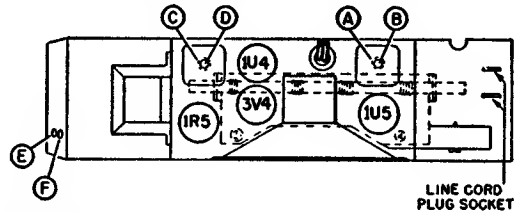

ALIGNMENT PROCEDURE

- Turn receiver volume control full on (fully clockwise).
- Use an isolation transformer if available; otherwise, connect a .1 mfd. capacitor in series with low side of signal generator and connect to chassis.
Caution: Do not connect a ground wire directly to chassis.
- Connect output meter across speaker voice coil.
- Use lowest output of signal generator required for midscale meter indication and proceed in the following sequence.
- Repeat adjustments to insure good results.

Step	Dummy Antenna in Series with Signal Generator	Connection of Signal Generator (High Side)	Signal Generator Frequency	Receiver Gang Setting	Trimmer Description	Trimmer Designation	Type of Adjustment
1	.1 mfd. capacitor	Antenna stator of tuning capacitor	455 KC	Gang fully open	2nd IF 1st IF	*A, B, *C, D	Maximum output
2	.1 mfd. capacitor	Antenna stator of tuning capacitor	1620 KC	Gang fully open	Oscillator	E	Maximum output
Set tuning pointer with tuning gang tuned to 1400 KC generator signal; see illustration below.							
3	Loop of several turns of wire, or place receiver lead close to receiver loop for adequate signal pickup.	No actual connection (signal by radiation)	1400 KC	Tune in generator signal	Antenna	F	Maximum output

*Adjustments A and C made from the underside of the chassis. Use an alignment tool with a blade 3/32" wide.

MANUAL OF 1954 MOST-OFTEN-NEEDED RADIO DIAGRAMS

Admiral

Models 5F31, -A, -B, 5F32, -A, -B, 5F33, -A, -B, 5F34B, 5F38, -A, -B. CHASSIS 5F3, 5F3A, 5F3B

Step	Dummy Antenna in Series with Signal Generator	Connection of Signal Generator (High Side)	Signal Generator Frequency	Receiver Gang Setting	Adjustment Description	Adjustment Designation	Type of Adjustment
1	.1 mfd. capacitor	Antenna stator of tuning capacitor	455 KC	Gang fully open	2nd IF 1st IF	A, B, C, D	Maximum output
2	.1 mfd. capacitor	Antenna stator of tuning capacitor	1620 KC	Gang fully open	Oscillator	E	Maximum output
Set tuning pointer with tuning gang tuned to 1400 KC generator signal; see illustration below.							
3	Loop of several turns of wire, or place generator lead close to receiver loop for adequate signal pickup.	No actual connection (signal by radiation)	1400 KC	Tune in generator signal	Antenna	F	Maximum output

+ ALTERNATE AUDIO COUPLING SYSTEM

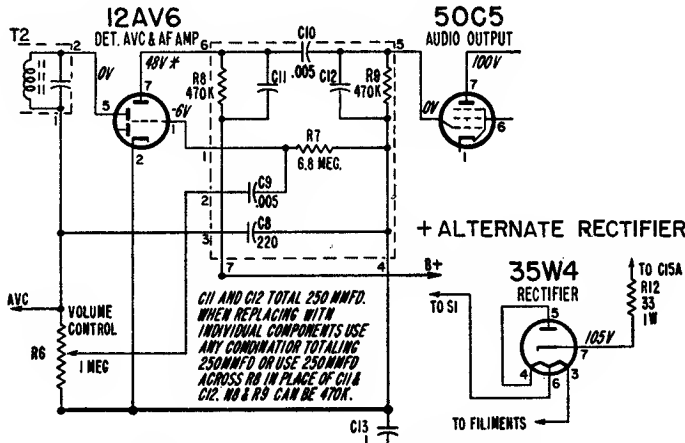

Voltagess shown on schematic diagram.

All readings made between tube socket terminals and B minus (terminal of On-Off switch).

Measured on 117 Volt AC line.

Volume control minimum; dial set at low frequency end.

Voltagess measured with vacuum-tube voltmeter.

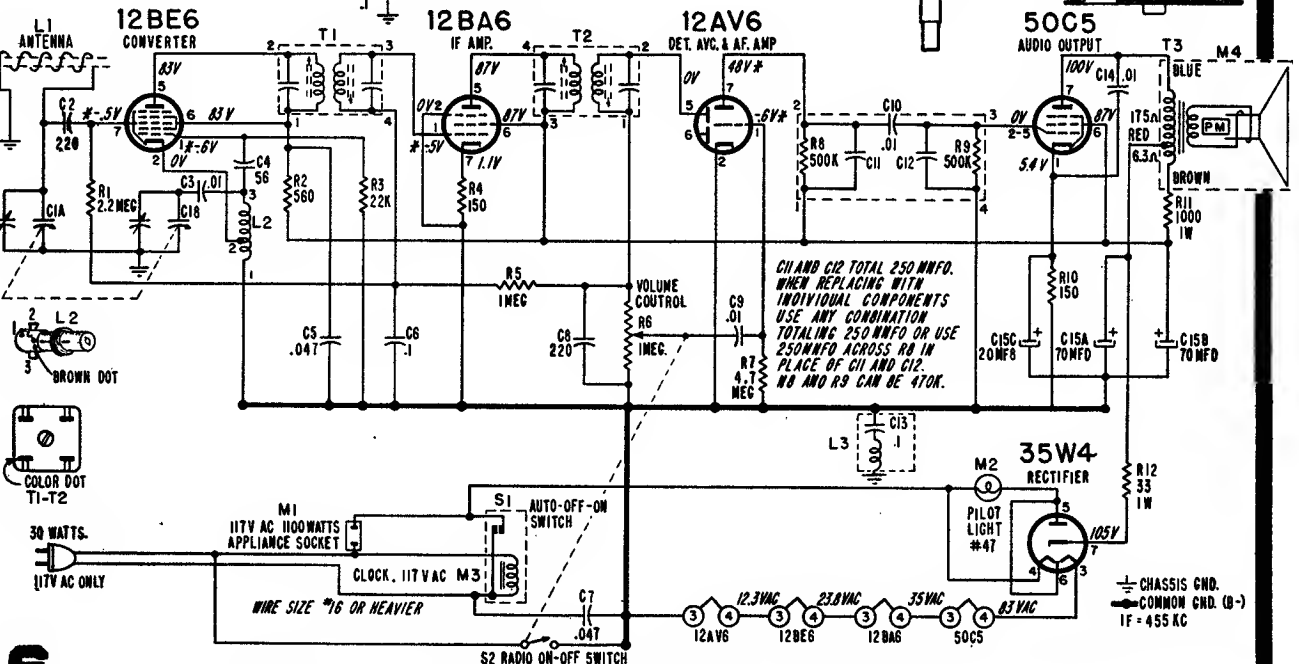
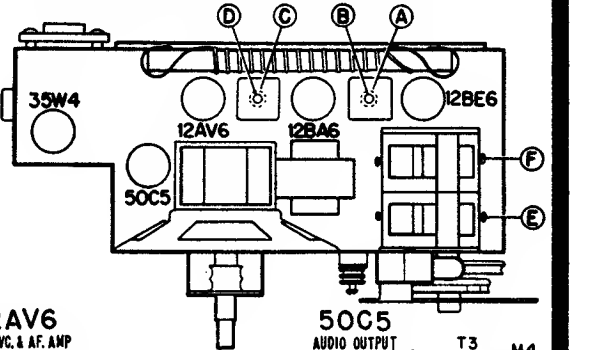

6

* THESE VOLTAGE READINGS WILL BE EITHER LOWER OR PRACTICALLY ZERO IF TAKEN WITH A 1000-ORMS-PER-VOLT METER.

+ USED ON 5F3A, 5F3B CHASSIS.

MANUAL OF 1954 MOST-OFTEN-NEEDED RADIO DIAGRAMS

Admiral

CHASSIS SG3
MODELS 5G31, 5G32, 5G33

(Continued on page 8, over)

REPLACEMENT OF COMPONENTS

This receiver employs the very latest in radio circuitry and printed circuit wiring technique. The printed circuit wiring used in this receiver replaces the hookup wire type of circuit wiring used in earlier receivers. See figure 1. The printed circuit wiring is permanently adhered to the underside of the plastic chassis base by a photo engraving process.

All components used in this receiver are of standard size and design. For servicing convenience, all components are mounted on the top side of the chassis, see figure 2.

To avoid damage to printed circuits by application of excessive heat when replacing components, use a soldering iron (60 watts or less) with a small tip. Do not use a soldering gun.

To remove a defective component, apply the tip of the soldering iron to the connection point at the underside of the chassis. Keep soldering iron on connection just long enough to melt the solder, then quickly tap the chassis against the service bench to shake the solder away from the connection. After the solder is removed, untwist or separate connections. A pick will be helpful for untwisting or separating connections. After disconnecting connecting wires or lugs, carefully remove components from the top side of the chassis.

Before installing replacement components, clean the solder from the connection point, so that the leads or lugs can be pushed through the holes in the

chassis panel. To avoid running solder into adjacent leads of the printed circuit, use as little solder as possible.

For quick replacement, resistors and capacitors may be replaced by clipping out the defective part and soldering the new part to the connecting leads remaining from the original part.

An open or damaged section of printed circuit wiring can be replaced by soldering a jumper of ordinary hookup wire across the connection points. To avoid need for complete tube socket replacement, defective tube socket pin clips may be replaced individually. Tube socket pin clips are available under part number 87A35-2.

Note: The tubular shield (center connection) at the bottom of each tube socket must be securely soldered to the printed circuit wiring, otherwise hum or oscillation will result.

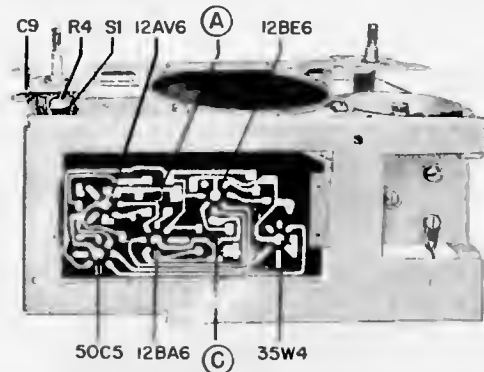

Figure 1. Bottom View of Chassis.

ALIGNMENT PROCEDURE

- Connect output meter across speaker voice coil.
- Turn receiver volume control full on.
- Use an isolation transformer if available, otherwise connect a .1 mfd. capacitor in series with low side of signal generator and connect to chassis. Caution: Do not connect a ground wire directly to chassis.
- Use lowest output setting of signal generator capable of producing adequate output meter indication and then proceed as outlined in chart below.
- Use a non-metallic alignment tool for IF transformers.
- Repeat adjustments to insure good results.

Step	Dummy Antenna In Series With Signal Generator	Connection of Signal Generator (High Side)	Signal Generator Frequency	Receiver Gong Setting	Trimmer Description	Trimmer Designation	Type of Adjustment
1	.001 mfd. capacitor	Antenna stator of tuning capacitor	455 KC	Gang fully open	2nd IF 1st IF	*A, B *C, D	Maximum Output
2	.001 mfd. capacitor	Antenna stator of tuning capacitor	1620 KC	Gang fully open	Oscillator (on gang)	E	Maximum Output
3	Loop of several turns of wire or place generator lead close to receiver loop for adequate signal pickup.	No actual connection (signal by radiation)	1400 KC	Tune in generator signal	Antenna (on gang)	F	Maximum Output
4	Set dial pointer slide as shown in Pointer Setting and Dial Cord Stringing Diagram below. Also see instructions on "Removing Or Installing Chassis In Cabinet" and on "Setting Pointer Slide."						

MANUAL OF 1954 MOST-OFTEN-NEEDED RADIO DIAGRAMS

Admiral

CHASSIS 5G3
MODELS 5G31, 5G32, 5G33

(Service material continued from page 7)

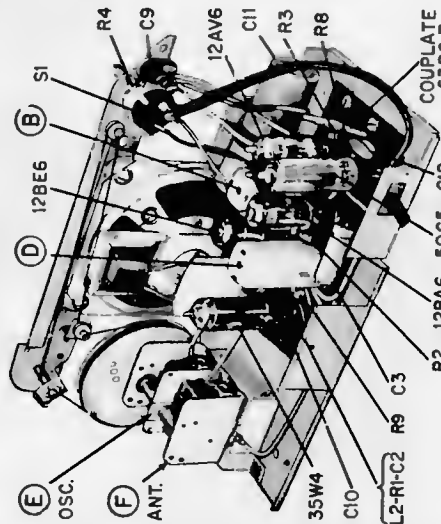
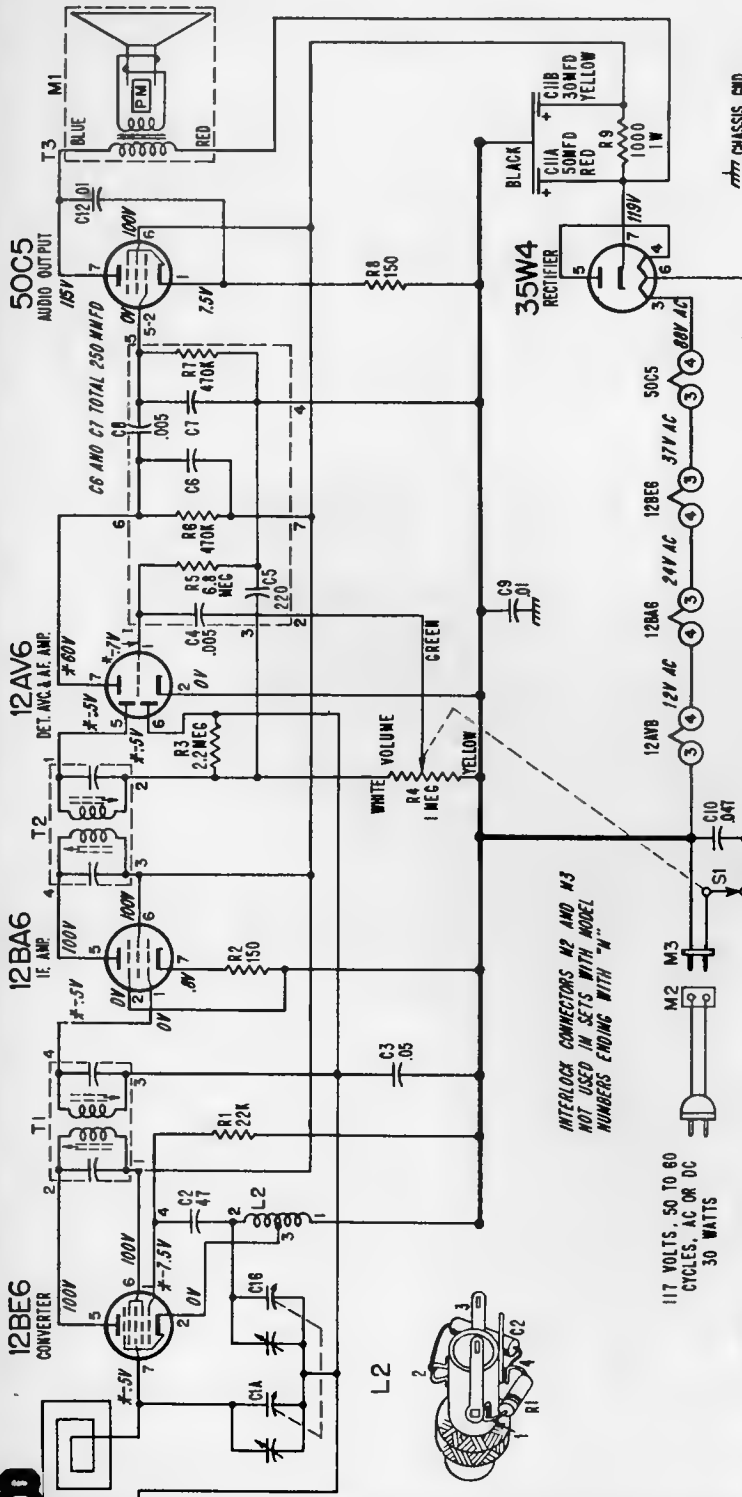

Figure 2. View of Chassis.

VOLTAGE DATA

Voltages shown on schematic diagram.
All readings made between tube socket terminals and B minus.

Dial turned to low frequency end; volume control at minimum.

Measured on 117 Volts AC line.

Voltages measured with vacuum-tube voltmeter.

The chassis of this receiver is connected directly to one side of the power line. To avoid possibility of damage to test equipment or to printed circuit wiring, do not place the chassis directly on a metal service bench, tools or other metal objects.

*These readings will be lower if taken with a 1000 ohms-per-volt meter.

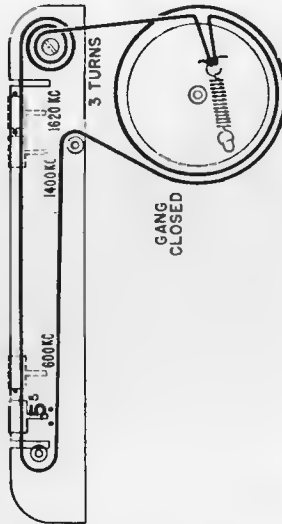

With the gang condenser fully closed, place the pointer slide nearest the volume control as shown in the figure above. The three punched holes indicate tracking points.

MANUAL OF 1954 MOST-OFTEN-NEEDED RADIO DIAGRAMS

Arvin INDUSTRIES INC.

Model 760T, Chassis RE-342

ALIGNMENT

PRELIMINARY:

Output meter connection..... Across speaker voice coil
 Output meter reading to indicate 500 Milliwatts (Standard output)..... 1.26 volts
 Connection of generator ground lead Floating ground
 Generator modulation..... 30% 400 cycles
 Position of volume control Fully clockwise

Position of Variable	Frequency of Generator	Dummy Antenna	Generator Output Connection	Trimmers Adjusted in Order Shown for Maximum Output	Function of Trimmer
Open	455 Kc	.05 uf	Pin 8 12SA7	A1, A2, A3, A4,	I. F.
Open	1650 Kc		Test Loop *	A5	Oscillator
1400 Kc	1400 Kc		Test Loop *	A6, A7 *	R. F. Antenna
600 Kc	600 Kc		Test Loop *	Check Point	

* Rock tuning shaft while A6 & A7 are being adjusted until no further output is obtained. Keep generator output at a low level to prevent detuning by AVC action.

* Test Loop: Hazeltine model 1150 or 3 turns of wire about 6" in diameter placed about one foot from the receiver antenna.

SCHEMATIC LOCATION	PART NO.	DESCRIPTION
CAPACITOR		
C1A, B, C	40548	Capacitor, Variable
C2, C5	20068-503	Capacitor, P. T., .05 uf, 400V.
C3	20067-503	Capacitor, P. T., .05 uf, 200V.
C4	20065-500	Capacitor, Mica, .00005 uf, 500V.
C6, C8	20203-221	Capacitor, Ceramic, .00022 uf, 350V.
C7, C9, C11	20068-103	Capacitor, P. T., .01 uf, 400V.
C10	20069-302	Capacitor, P. T., .003 uf, 600V.
C12, A, B,	24249	Capacitor, Electrolytic 80-50-150V.
C13	20067-102	Capacitor, P. T., .001 uf, 200V.

RESISTOR		
R1, R9	20061-334	Resistor, 330K. ohm, 1/2W 20%
R2	20061-222	Resistor, 2200 ohm, 1/2W 20%
R3	20061-223	Resistor, 22K. ohm, 1/2W 20%
R4	20061-685	Resistor, 6.8 meg. 1/2W 20%
R5	20061-105	Resistor, 1 meg. 1/2W 20%
R6	20061-150	Resistor, 15 ohm, 1/2W 20%
R8	20061-335	Resistor, 3.3 meg. 1/2W 20%
R11, R13	20061-151	Resistor, 150 ohm, 1/2W 20%
R12	20223-102	Resistor, 1000 ohm, 2W 10%
R14	20061-333	Resistor, 33K, 1/2W 20%
R15	20061-680	Resistor, 68 ohm, 1/2W 20%

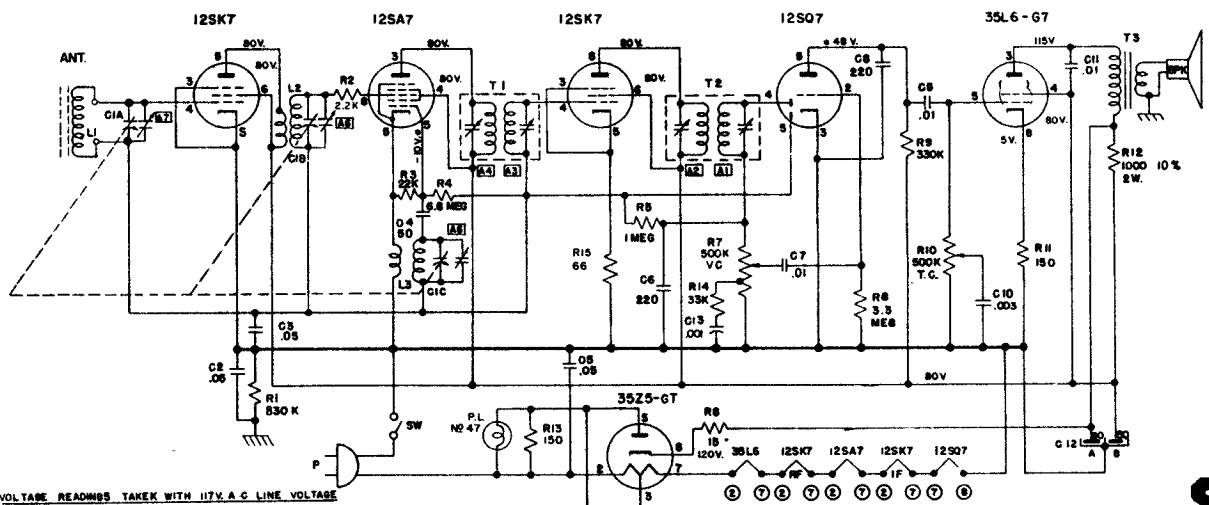
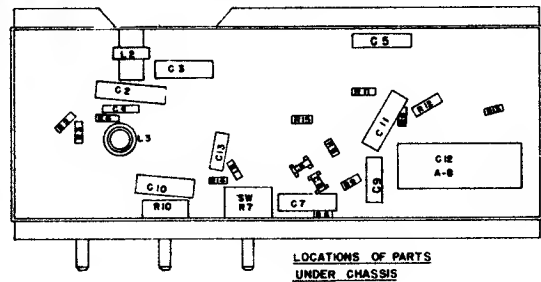
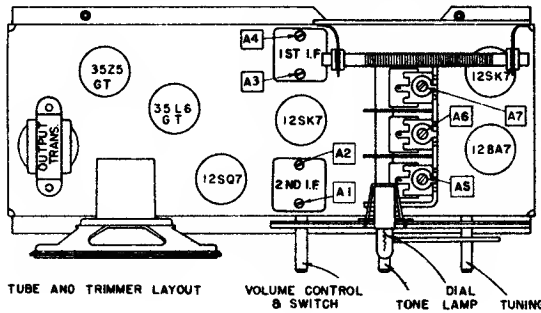

VOLTAGE READINGS TAKEK WITH 117V. A.C. LINE VOLTAGE
 * THESE READINGS TAKEN WITH VACUUM TUBE VOLTMETER

MANUAL OF 1954 MOST-OFTEN-NEEDED RADIO DIAGRAMS



Arvin INDUSTRIES INC.

MODEL 758 T

Chassis RE-350

ALIGNMENT PROCEDURE

PRELIMINARY:

Output meter connection Across speaker voice coil
 Output meter reading to indicate 500 milliwatts (Standard output)..... 1.26 volts
 Connection of generator ground lead Floating ground
 Generator modulation 30% 400 cycles
 Position of volume control Fully clockwise

Position of Variable	Frequency of Generator	Dummy Antenna	Generator Output Connection	Trimmers Adjusted in Order Shown for Maximum Output	Function of Trimmer
Open	455	.05 mfd.	Pin 7 12BE6	A1, A2, A3, A4	I. F.
Open	1650		* Test Loop	A5	Oscillator
1400	1400		* Test Loop	A6 on	Antenna
600	600		* Test Loop	*Check Point	

*Standard Hazeltine Test Loop Model 1150 or 3 turns of wire about 6" in diameter placed about one foot from the set loop.

The alignment procedure should be repeated in the original order for greatest accuracy.

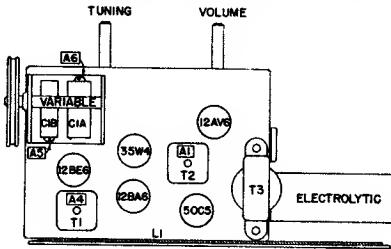

TUBE LAYOUT

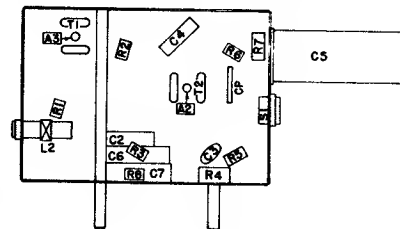
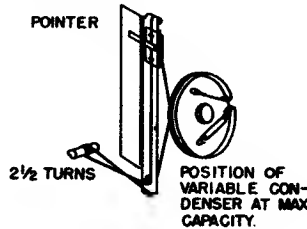

LOCATION OF PARTS UNDER CHASSIS

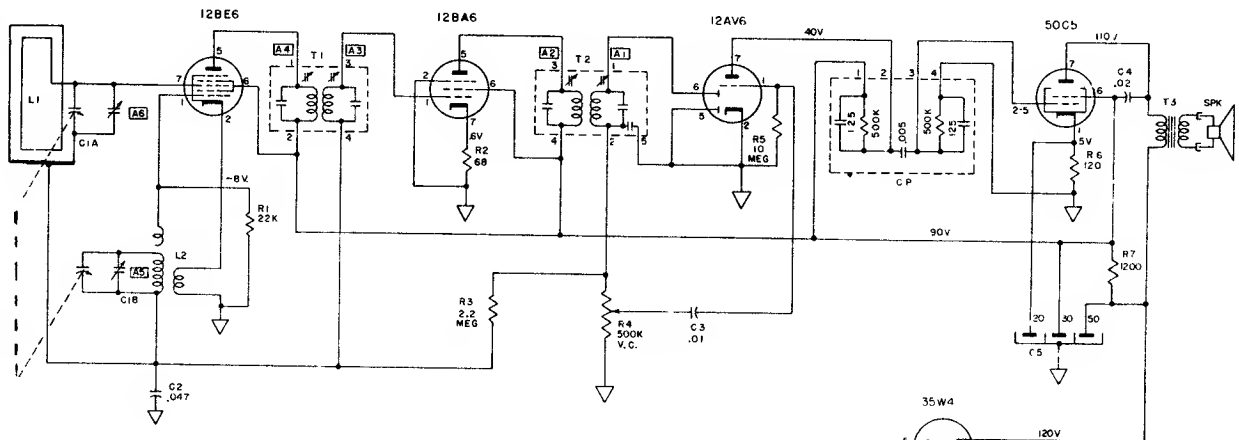

VOLTAGES MEASURED WITH VACUUM TUBE VOLTMETER TO B- WITH 117 VOLTS AC INPUT.
 ↓ INDICATES B-
 ⊕ INDICATES GROUND TO CHASSIS.
 ⊕ CURVED LINE INDICATES OUTSIDE POLE

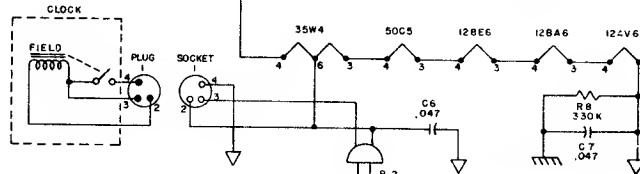

MANUAL OF 1954 MOST-OFTEN-NEEDED RADIO DIAGRAMS



Arvin INDUSTRIES INC.

MODEL 746P

MODEL 747P (CLOCK)

Chassis RE-347

ALIGNMENT PROCEDURE

PRELIMINARY

Output meter reading to indicate .05 watt across voice coil 0.4V
 Generator ground lead connected to metal chassis
 Generator modulation 30% 400 cycles
 Position of Volume Control fully on

Position of Variable	Generator Frequency	Dummy Antenna	Generator Connections	Adjust Trimmers (In order shown)	Function of Trimmer
Open	455Kc	.05 MFD	Mixer Grid	A1, A2, A3, A4,	I. F.
Open	1650Kc		* Test Loop	A5	Oscillator
1400Kc	1400Kc		* Test Loop	A6	Antenna
600Kc	600Kc		* Test Loop	Check Point	

* Standard Hazeltine Test Loop Model 1150 or 3 turns of wire about 6" in diameter placed about one foot from the set loop.

The alignment procedure should be repeated in the original order for greatest accuracy.

TO INSTALL BATTERIES

1. Turn cabinet upside down with front open to expose battery compartment.
2. Remove wingscrew take out the "B" battery clip.
3. Push the "A" battery into it's compartment making sure that the terminal end is facing the output transformer.
4. Snap the "B" battery terminals and slide battery into it's compartment.
5. Replace the battery clip with the wingscrew and close the cabinet.

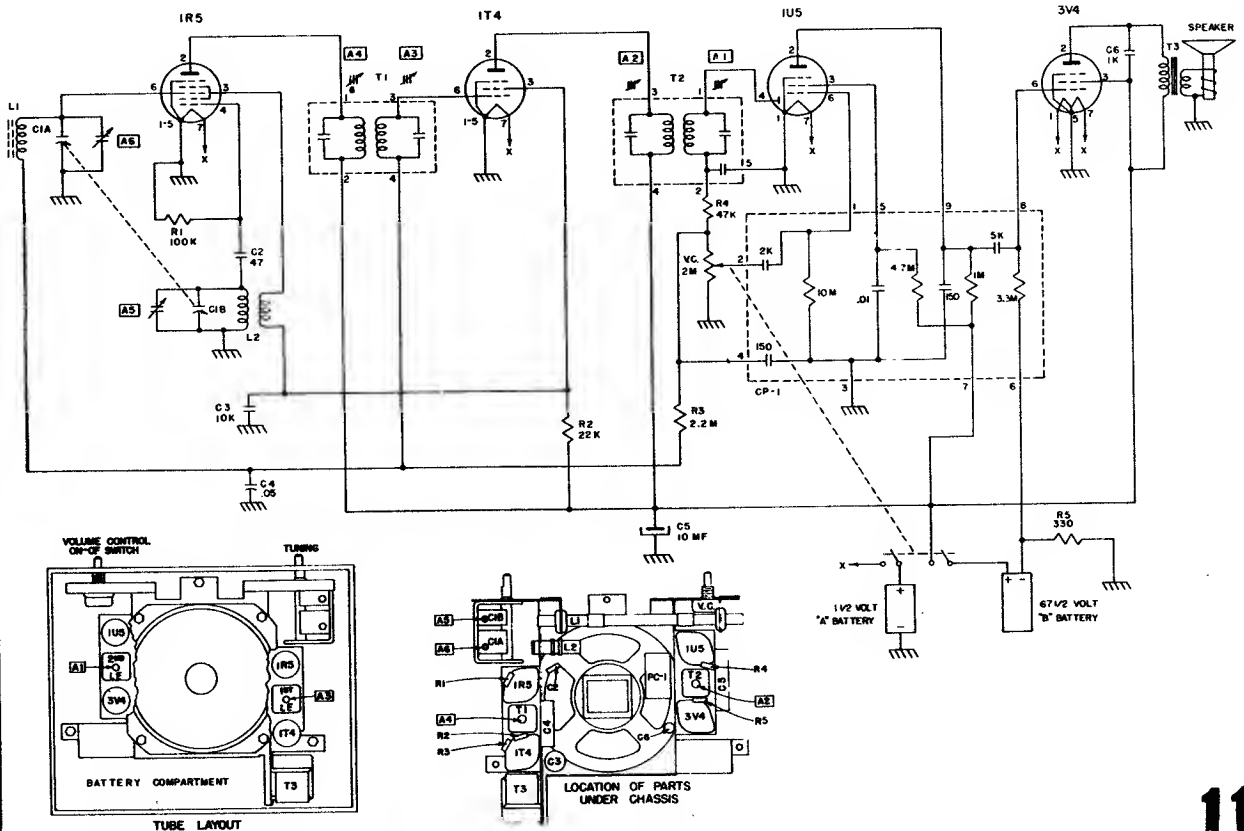

MANUAL OF 1954 MOST-OFTEN-NEEDED RADIO DIAGRAMS

ARVIN Industries, Inc.

Model 753T, Chassis RE-348

ALIGNMENT

PRELIMINARY:

Output meter connection Across speaker voice coil
 Output meter reading to indicate 500 milliwatts (standard output) 1.26 volts
 Connection of generator ground lead Floating ground
 Generator modulation 30% 400 cycles
 Position of volume control Fully clockwise

Position of Variable	Frequency of Generator	Dummy Antenna	Generator Output Connection	Trimmers Adjusted in Order Shown for Maximum Output	Function of Trimmer
Open	455	.05 mfd.	Pin 7 12BE6	A1, A2, A3, A4	I. F.
Open	1650		* Test Loop	A5	Oscillator
1400	1400		* Test Loop	A6	Antenna
600	600		* Test Loop	Check Point	

* Standard Hazeltine Test Loop Model 1150 or 3 turns of wire about 6" in diameter placed about one foot from the set loop.

The alignment procedure should be repeated in the original order for greatest accuracy. Always keep the output from the signal generator at its lowest possible value to make the AVC action of the receiver ineffective.

Note: Some sets were built without C8 capacitor 1000uuf Disc. and R9 resistor 68K 1/2W 20%. . C6 capacitor .02 was .05.

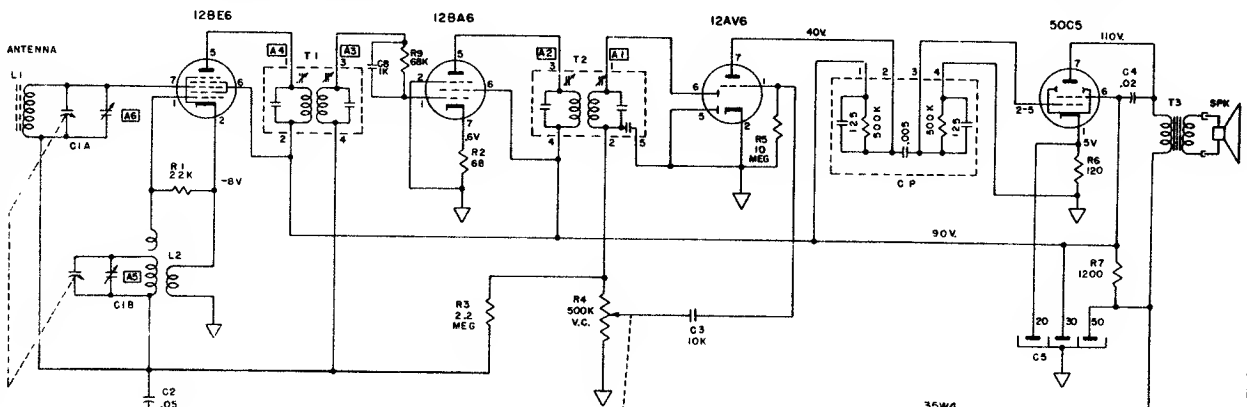
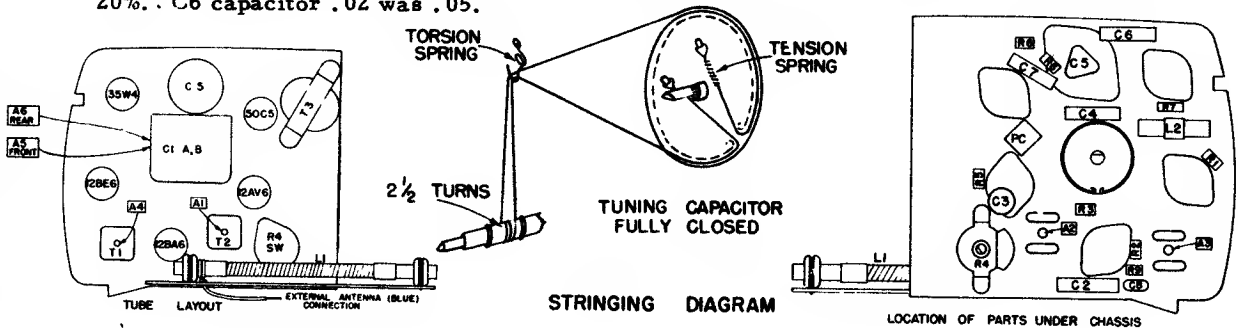

MODEL 753T

VOLTAGES MEASURED WITH VACUUM TUBE VOLTMETER TO B- WITH 117 VOLTS AC INPUT
 ↓ INDICATES B-
 ⊕ INDICATES GROUND TO CHASSIS
 ⤵ CURVED LINE INDICATES OUTSIDE FOIL

MANUAL OF 1954 MOST-OFTEN-NEEDED RADIO DIAGRAMS

Arvin

Radio

Arvin INDUSTRIES INC.

Model 741T, Chassis RE-352

ALIGNMENT PROCEDURE

PRELIMINARY					
Output meter connection	Speaker voice coil				
Output meter reading to indicate .5 watt output	1.26 Volts				
Connection of generator ground lead	Floating ground				
Generator Modulation	30% 400 cycles				
Position of volume control	Fully clockwise				

Position of Variable	Frequency of Generator	Dummy Antenna	Generator Output Connection	Trimmer Adjustment for Maximum Output	Function of Trimmer
Open	455 Kc	.05 uf	Pin 7 12BE6	A1, A2	I. F.
1400 Kc	1400 Kc	50 uuf	Antenna Clip (Blue wire disconnected)	A3 Rock Variable while making this adj. to track antenna	Oscillator
600 Kc	600 Kc	50 uuf	Antenna Clip (Blue wire disconnected)	Antenna sections plates	Check point

Keep signal generator at a low value to prevent detuning by AVC action.

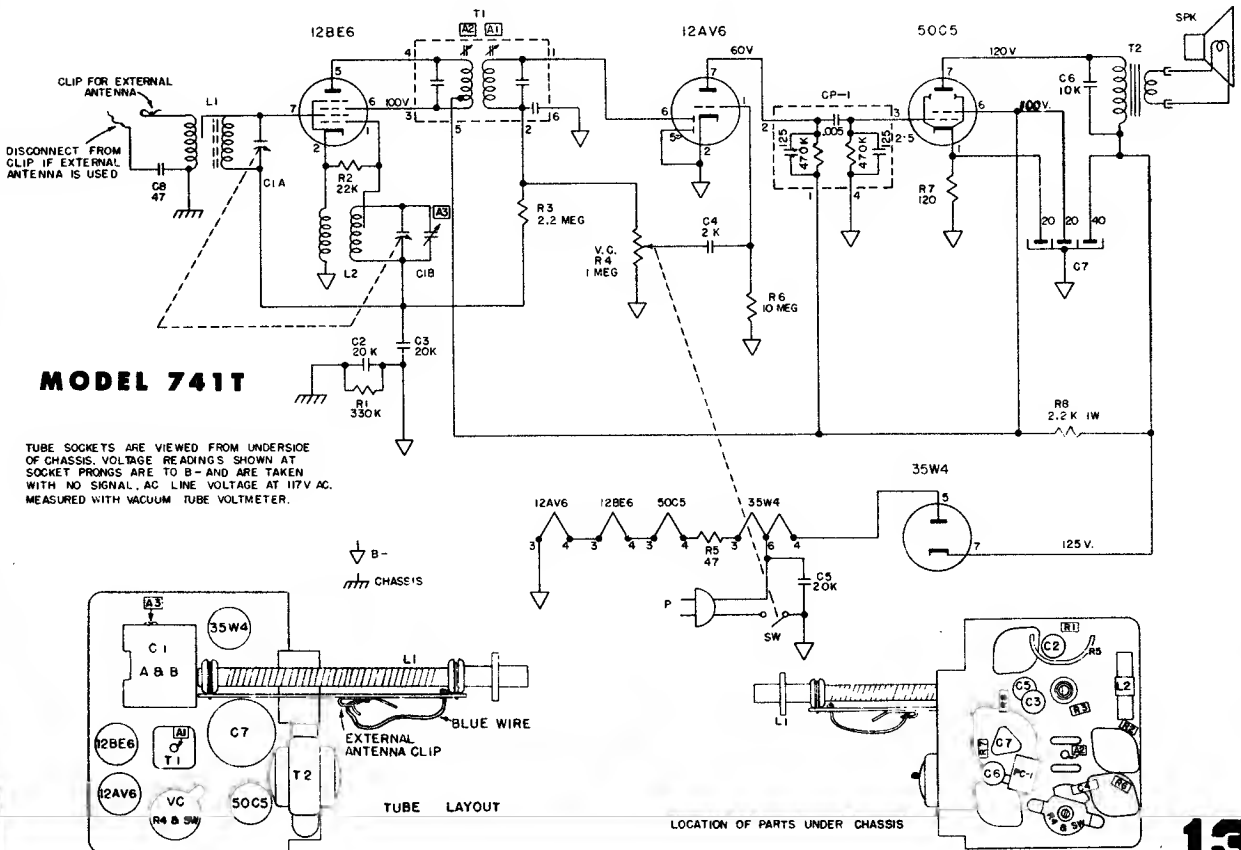

MANUAL OF 1954 MOST-OFTEN-NEEDED RADIO DIAGRAMS

ARVIN Industries, Inc. Models 581, 780TFM,
Chassis RE-333

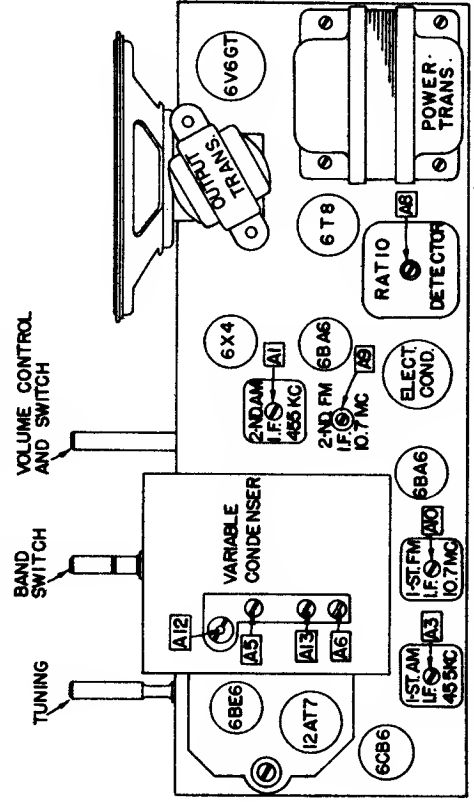
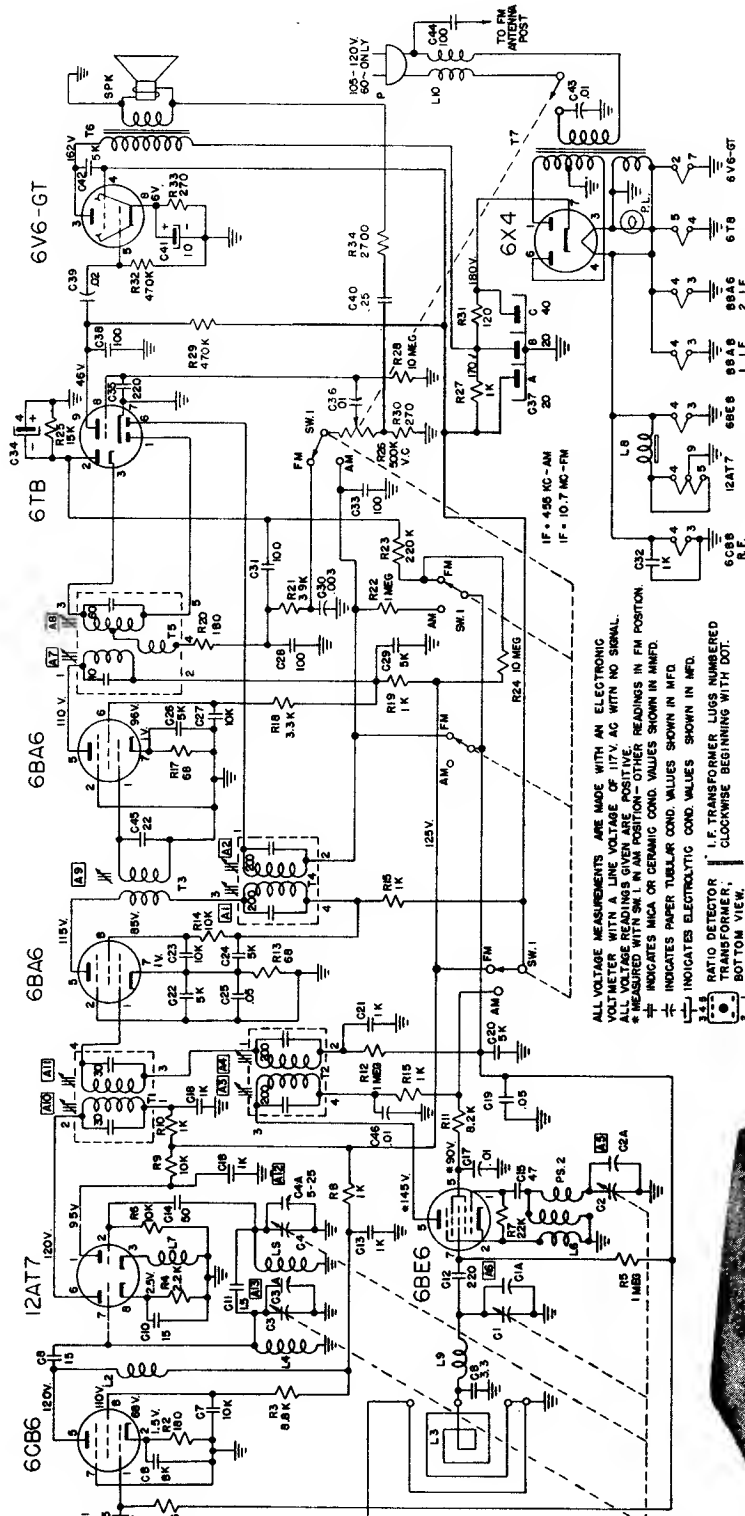

ALL VOLTAGE MEASUREMENTS ARE MADE WITH AN ELECTRONIC VOLTMETER WITH A LINE VOLTAGE OF 117V AC WITH NO SIGNAL. ALL VOLTAGE READINGS GIVEN ARE POSITIVE. * MEASURED WITH SW-1 IN AM POSITION - OTHER READINGS IN FM POSITION. † INDICATES MICRA OR CERAMIC COND. VALUES SHOWN IN MINIF. ‡ INDICATES PAPER TUBULAR COND. VALUES SHOWN IN MFD. § RATIO DETECTOR. †† L.F. TRANSFORMER LUGS NUMBERED TRANSFORMER. ††† CLOCKWISE BEGINNING WITH DOT. †††† BOTTOM VIEW.

Alignment on
the next page.



- Chassis 333-1 differs from chassis 333 as follows:
- R29, 330K changed to R29, 470K part number 20061-474.
 - R30, 150K changed to R30, 270 ohm part number 22381-271.
 - C40, 220 uuf changed to C40, .25 uf part number 20067-254.
 - R34, 2700 ohm part number 20061-272 was added.

MANUAL OF 1954 MOST-OFTEN-NEEDED RADIO DIAGRAMS

ARVIN Industries, Inc. Models 581, 780TFM, Chassis RE-333
(See preceding page for circuit diagram)

ARVIN Industries, Inc. Models 581, 780TFM, Chassis RE-333, (continued)

AM Tuning range --- 540 Kc to 1600 Kc. Intermediate Frequency --- 455 Kc. I.F. and R.F. measurements made at 600 milliwatts output --- approximately 1.27 volts on a rectifier type voltmeter connected across speaker voice coil.

Approximately input for 500 MF output; I.F. 300 uv; R.F. with standard loop; at 800 Kc, 900 uv; at 1000 Kc, 700 uv; at 1400 Kc, 800 uv/m.

FM Tuning range --- 88 megacycles to 108 megacycles. Intermediate Frequency 10.7 megacycles. I.F. and R.F. measurements made at 500 milliwatts output --- approximately 1.27 volts on a rectifier type voltmeter connected across speaker voice coil. Approximate input for 500 MF output; I.F. 300 uv; R.F. "Absolute Measurements"; 91 megacycles, 80 uv; 108 megacycles, 70 uv.

ALIGNMENT PROCEDURE

Output meter connection.....across speaker voice coil. Output meter reading to indicate 500 MF.....1.27 volts. Generator Modulation.....30%, 400 cycles. Position of volume control.....Fully clockwise. Set dial pointer.....Horizontal, variable condenser closed. Set band switch.....To left for AM alignment, right for FM alignment.

AM ALIGNMENT

Position of Variable	Generator Frequency	Dummy Ant.	Generator Connection (high)	Adjust Trimmers In Order Shown For Max. Output	Trimmer Function
Open	455 Kc	.05 Mfd.	Mixer Grid	A1, A2, A3, A4	I.F. Oscillator
Open	1650 Kc		*Test Loop	A5	Antenna
1400 Kc	1400 Kc		*Test Loop	A5	Antenna
*500 Kc	800 Kc		*Test Loop	Check Point	Antenna

Connect generator lead to a Standard Hazeltine Test Loop Model 1180, placed two feet from the set loop, or three turns of wire about six inches in diameter, placed about one foot from the set loop. Or the generator can be connected with the high side lead to the AM antenna screw terminal and the ground lead to the chassis.

With the generator signal of 600 Kc, tune the set to the point where maximum output is obtained, which should be approximately 600 Kc on the dial. Adjust antenna section slotted blades of variable capacitor for maximum output.

The alignment procedure should be repeated in the original order for greatest accuracy.

Always keep the output from the signal generator at its lowest possible value to make the A.V.C. action of the receiver ineffective.

FM ALIGNMENT

1. Connect FM Generator, High Side, to grid (pin 1) of 6BA6 End I.F. tube through .005 mfd. dummy.
2. Set generator frequency to 10.7 Mc. modulated either 60 cycles or 400 cycles, 250 Kc sweep (125 Kc. deviation.)
3. Connect vertical input of scope across volume control of receiver (grounded terminal to chassis, ungrounded terminal to high side of control.)
4. Set scope switch for external sweep and horizontal oscillator off.
5. Turn variable condenser fully open and band switch to right (FM).

8. Adjust phase shift control in horizontal sweep lead to make double trace on scope coincide.
7. Adjust ratio detector primary slug No. A7 for maximum vertical sweep of the scope pattern.

8. Adjust ratio detector secondary slug No. A8 to center the cross over point of the pattern. Pattern should look like Fig. 1, with the same amount of curve on both ends, and the cross over point in the center.

9. Connect generator high side to pin 1 of the first I.F. tube through .005 dummy. Set generator deviation to 25 Kc. Remove scope terminals from volume control and connect output meter across the voice coil.

10. With volume control maximum and signal reduced to give standard output peak I.F. slug A9 for maximum.

11. Connect generator converter grid (12A7, pin 7) and tune I.F. slugs A10 and (A-11) for maximum output. Also retouch A9 slightly for maximum output.

12. RF alignment. Generator should be modulated with 400 cps with 45 Kc sweep (22.5 Kc deviation). Output of generator should be connected to antenna terminals of set with a 270 ohm dummy in series with generator high-side lead. Use only enough signal to give standard output.

13. With variable condenser completely open and Signal Generator tuned to 108.5 Mc adjust oscillator trimmer A-12 (small ceramic trimmer) for maximum reading on output meter. Then tune receiver to low end of band (variable completely closed) and Signal Generator to 87.5 mc. If the receiver does not tune to this frequency, the FM oscillator coil L-6 will either have to be squeezed together or lengthened to cover the band, (squeezing lowers and lengthening raises the frequency). Any change in the coil will necessitate readjusting trimmer, A-12 at the high end of the band.

14. With the same Signal Generator connections as in paragraph 13, tune Signal Generator and set to 106 mc. Tune RF trimmer A-13 for maximum output at the same time rock variable back and forth through the frequency. (Rocking is necessary because slight oscillator pulling causes erroneous maximum readings.) Tune Signal Generator and set to 90 mc. Adjust R. F. coil L-4 length for maximum output by squeezing or lengthening. Any change in the coil will have to be compensated at 105 mc by the R.F. trimmer A-13.

15. After steps 4 and 5 are finished, check calibration and band coverage. Steps 4 and 5 have to be repeated if set is off calibration. Band coverage should be 87.5 mc to 108.5 mc. Sensitivity should be approximately 70 uv at 106 mc, 90 uv at 91 mc.

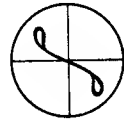

FIG. 1
RATIO DETECTOR
CURVE

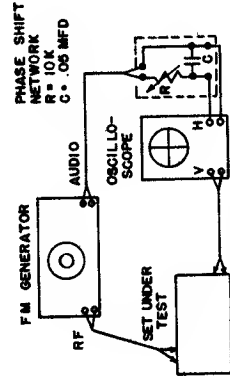

FIG. 2
INSTRUMENT
CONNECTIONS

MANUAL OF 1954 MOST-OFTEN-NEEDED RADIO DIAGRAMS

BENDIX RADIO

Models M-4, M-4A, & M-4B (used by Ford)

MODEL M-4A

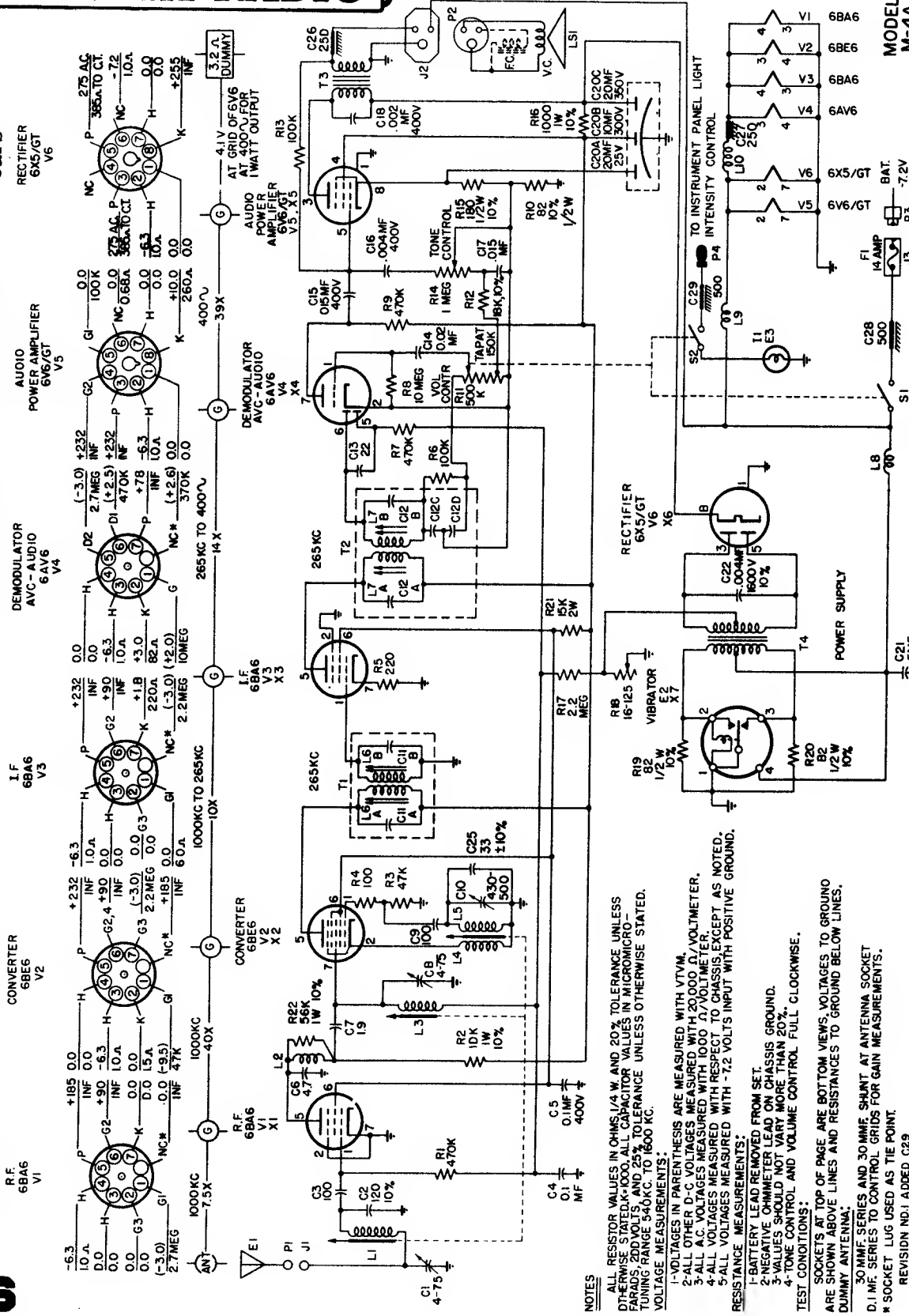

M-4B does not have spark plate C29

M-4 does not have spark plate C29

- NOTES**
- 1- ALL RESISTOR VALUES IN OHMS, 1/4 W. AND 20% TOLERANCE UNLESS OTHERWISE STATED.
 - 2- ALL OTHER D-C VOLTAGES MEASURED WITH 20,000 Ω/VOLTMETER.
 - 3- ALL A-C VOLTAGES MEASURED WITH 1000 Ω/VOLTMETER.
 - 4- ALL VOLTAGES MEASURED WITH RESPECT TO CHASSIS, EXCEPT AS NOTED.
 - 5- ALL VOLTAGES MEASURED WITH -7.2 VOLTS INPUT WITH POSITIVE GROUND.
- VOLTAGE MEASUREMENTS:**
- 1- BATTERY LEAD REMOVED FROM SET.
 - 2- NEGATIVE OHMMETER LEAD ON CHASSIS GROUND.
 - 3- VALUES SHOULD NOT VARY MORE THAN 20%.
 - 4- TONE CONTROL AND VOLUME CONTROL FULL CLOCKWISE.
- TEST CONDITIONS:**
- SOCKETS AT TOP OF PAGE ARE BOTTOM VIEWS. VOLTAGES TO GROUND, DUMMY ANTENNA, ARE SHOWN ABOVE LINES AND RESISTANCES TO GROUND BELOW LINES.
- 30MFMF SERIES AND 30MFMF SHUNT AT ANTENNA SOCKET
- D.1 MF. SERIES TO CONTROL GRIDS FOR GAIN MEASUREMENTS.
- * SOCKET LUG USED AS TIE POINT.
- REVISION NO.1 ADDED C29

MANUAL OF 1954 MOST-OFTEN-NEEDED RADIO DIAGRAMS

Bendix RADIO

MODELS 953A - 953B - 953C - 953D

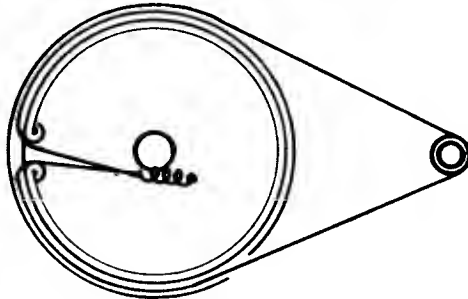

GANG FULLY CLOSED

Clock Models 853A, 853B, 853C, 853D, are similar but use a clock switching circuit.

3 TURNS

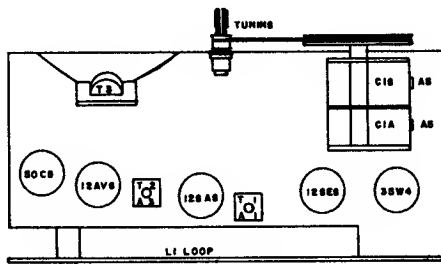
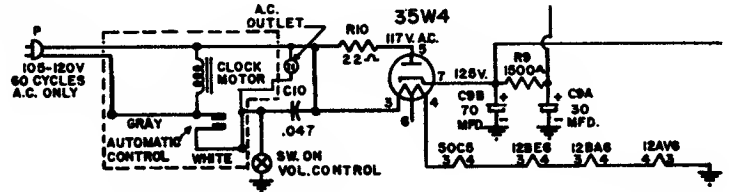

LOCATION OF TUBES & TRIMMERS

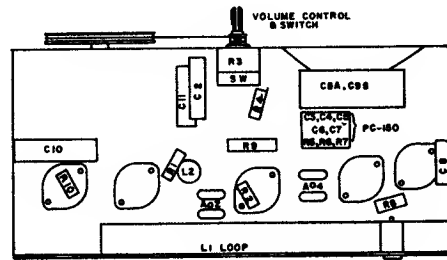

LOCATION OF PARTS UNDER CHASSIS

ALIGNMENT DATA

Position of Variable	Generator Frequency	Dummy Ant.	Generator Connection (high)	Generator Connection (low)	Adjust Trimmers (in order shown)	Trimmer Function
Open	455 Kc	.05 mfd	Mixer Grid	B-	A4, A3, A2, A1	I.F.
Open (Fully)	1640 Kc	50 mmf	*	B-	A6	Osc.
1400 Kc	1400 Kc	50 mmf	*	B-	A5	Ant.
1000 Kc	1000 Kc	50 mmf	*	B-	Check Point	
600 Kc	600 Kc	50 mmf	*	B-	Check Point	

* A loop fashioned of several turns of wire radiating the signal into the receiver's antenna or through the external antenna connection.

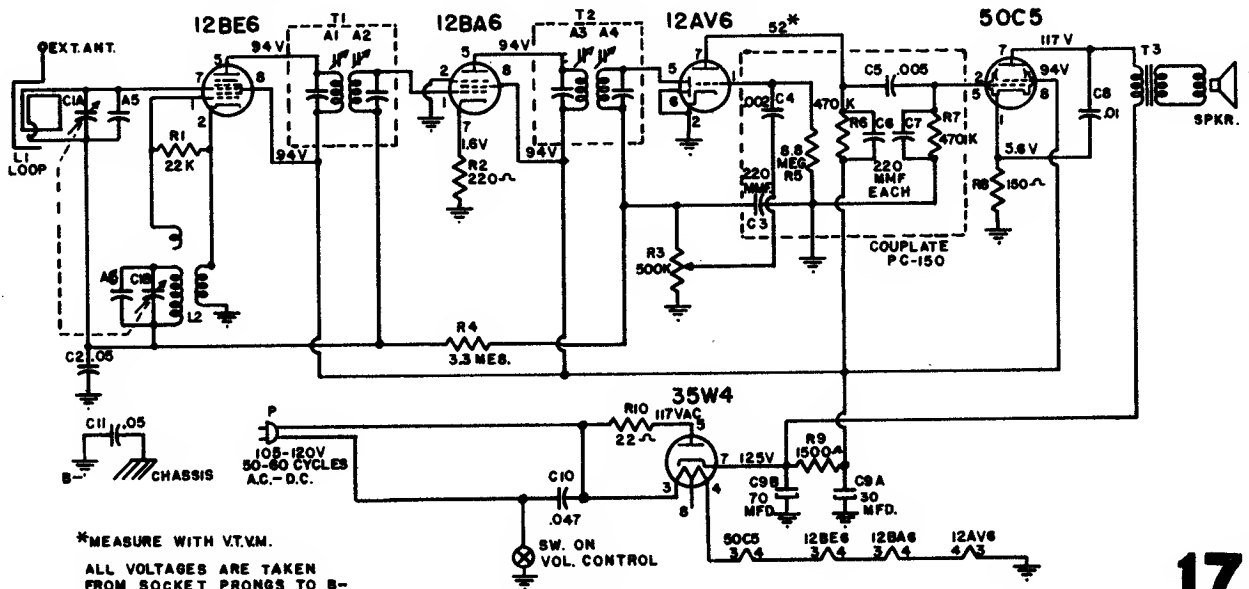

*MEASURE WITH VT.VM.
ALL VOLTAGES ARE TAKEN FROM SOCKET PRONGS TO B-

MANUAL OF 1954 MOST-OFTEN-NEEDED RADIO DIAGRAMS

Bendix

MODELS 753M, 753W, & 753F

BENDIX TELEVISION AND RADIO

DIVISION OF BENDIX AVIATION CORPORATION TUNING CONDENSER FULLY CLOSED

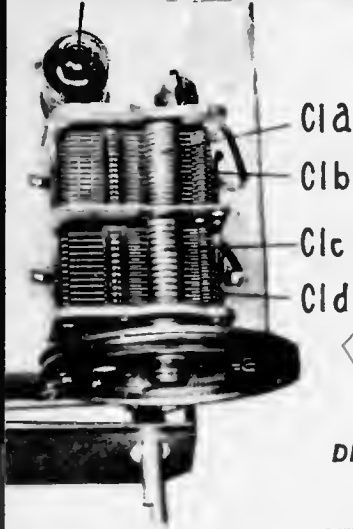

DIAL BACK PLATE REFERENCE MARKS

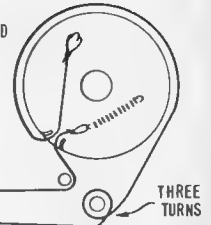

ALIGNMENT PROCEDURE

Signal Generator Coupling	Signal Generator Frequency	Dial Setting	Connect	Adjust	Remarks
High side through .01 to pin 7 (Grid) of 12BE6 Low side to B-	455KC	Max. to right	Output Meter across voice coil	T3, T2	Adjust in order given for max. meter reading
A loop fashioned of several turns of wire radiating the signal into the receivers antenna	1640	To the correct dial marking See Fig. 4	Same	C1d	Adjust for max. meter reading
Same	1475	To correct dial mark-	Same	C1b	Adjust for max. meter reading

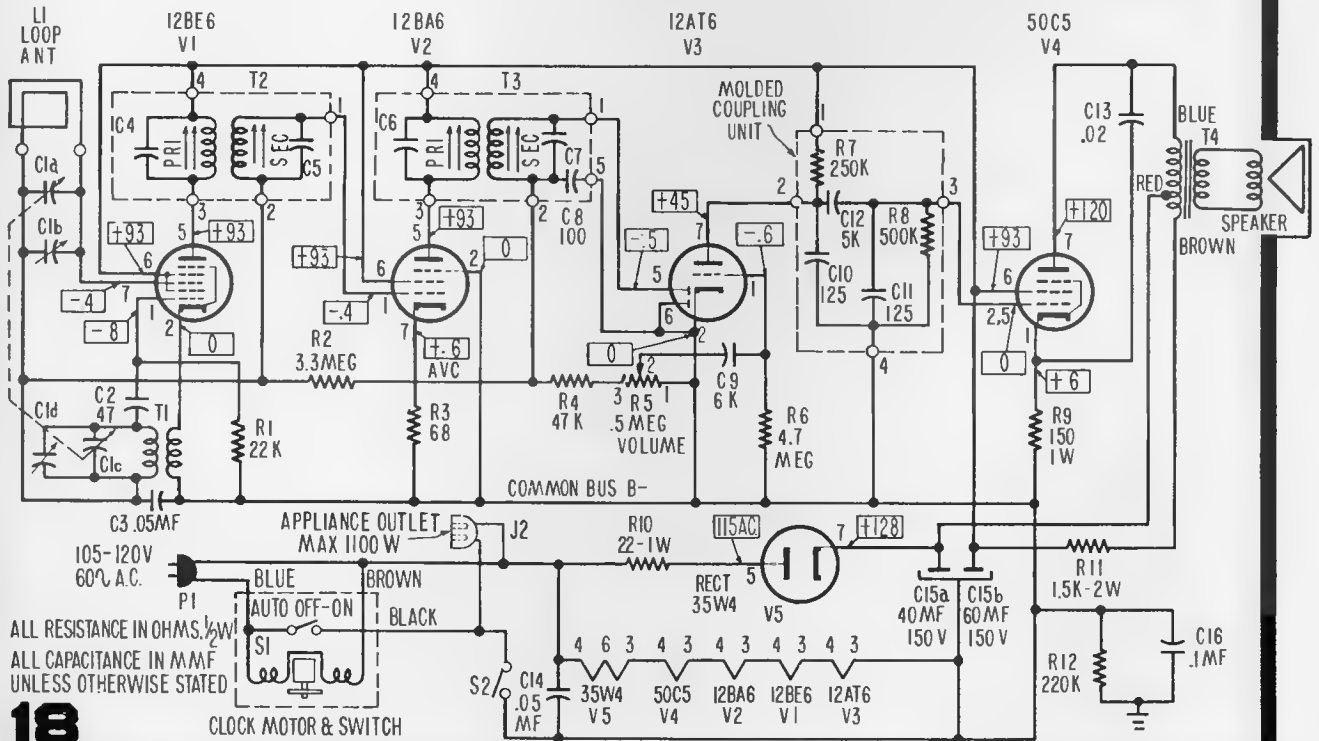

ALL RESISTANCE IN OHMS, $\frac{1}{2}$ W
ALL CAPACITANCE IN MMF
UNLESS OTHERWISE STATED

MANUAL OF 1954 MOST-OFTEN-NEEDED RADIO DIAGRAMS

CAPEHART - FARNSWORTH

Model T-54
Chassis CR-130

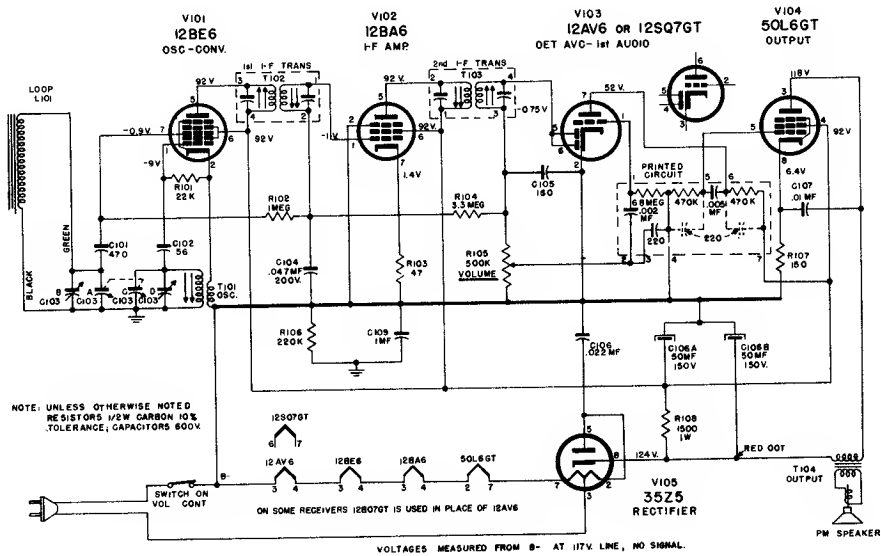

Step	Set Generator	Set Gang	Connect Generator	Adjust	To Obtain
1	455KC	Fully Open	Pin 1 V102	T104 (Top & Bottom)	Maximum
2	"	" "	Across Rod Ant.	T103 (Top & Bottom)	"
3	1620KC	Fully Open	Across Rod Ant.	Oscillator Trimmer	"
4	537KC	Closed	" " "	T101	"
5	1500 KC	1500KC	Loosely Couple To Rod Ant.	Antenna Trimmer	"

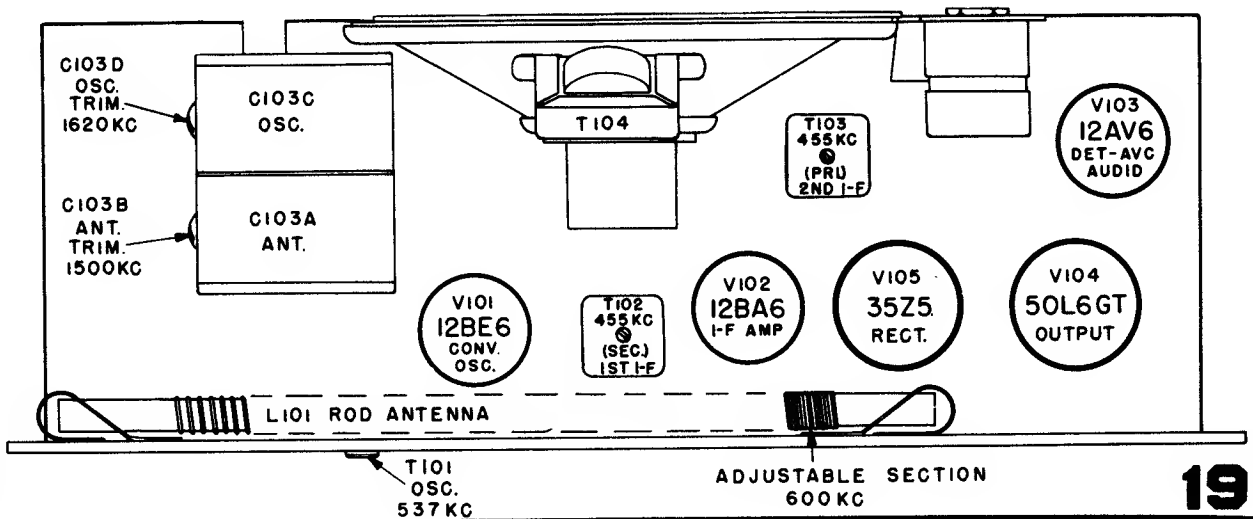

MANUAL OF 1954 MOST-OFTEN-NEEDED RADIO DIAGRAMS

Capehart

Circuit for Model RP-254, Chassis CR-147,
Model RP-153, Chassis CR-79, is similar.

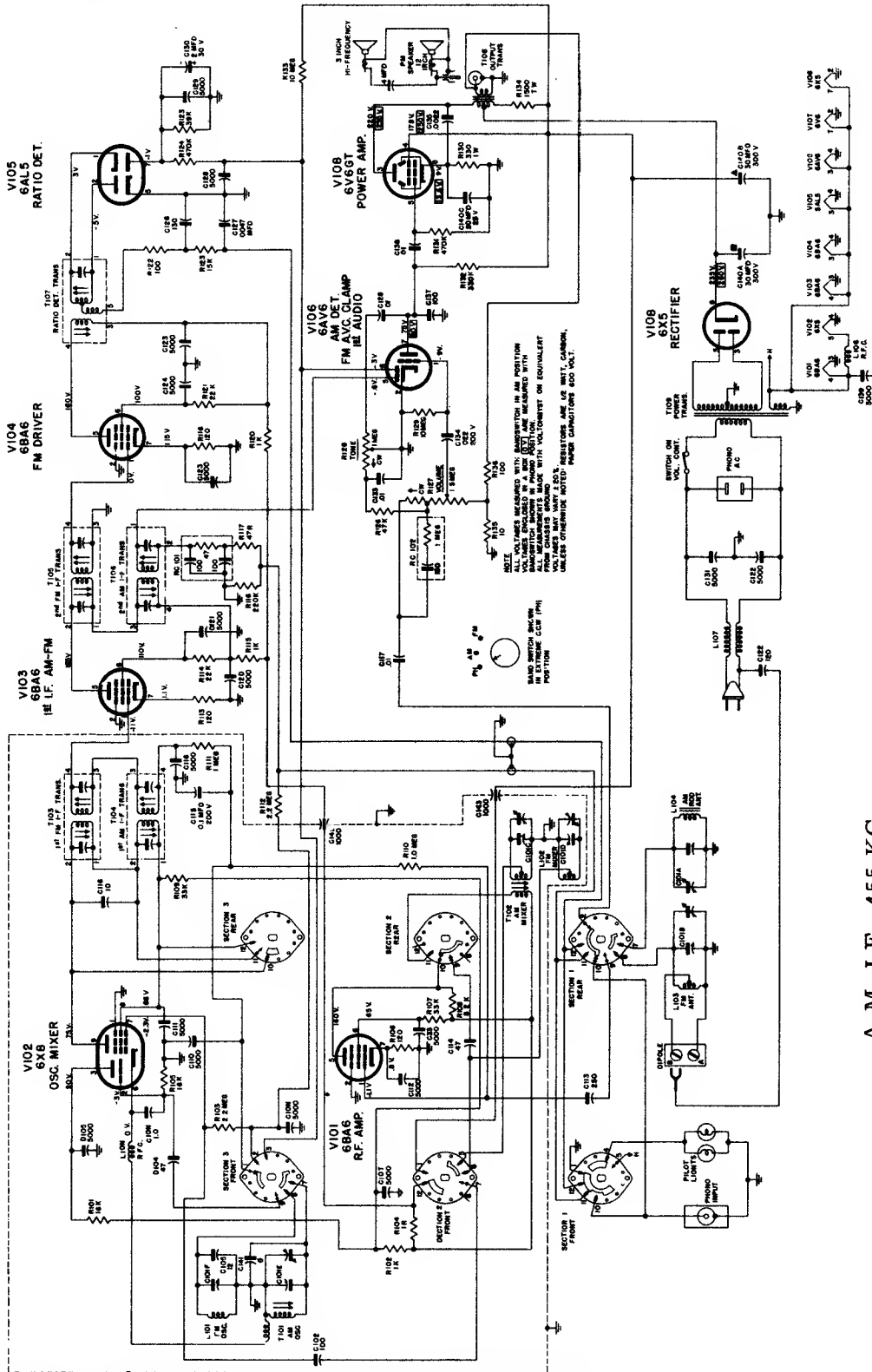

A.M. I.F. 455 KC.
F.M. I.F. 10.7 MC.

MANUAL OF 1954 MOST-OFTEN-NEEDED RADIO DIAGRAMS

CBS-Columbia, Table Model Radio
Chassis 515-1

MODELS 5165-Ebony; 5165-Ivory; 5165-Maroon

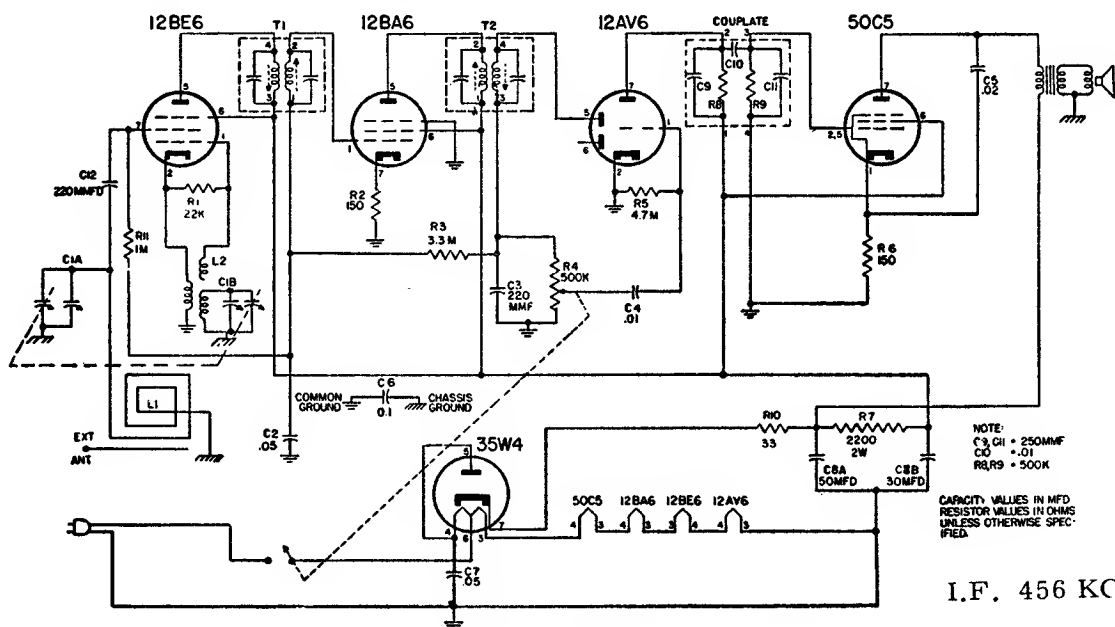

I.F. 456 KC.

CBS-Columbia, Personal Clock Radio
Chassis 5C1

MODELS 5330-Ebony; 5330-Ivory; 5330-Gray

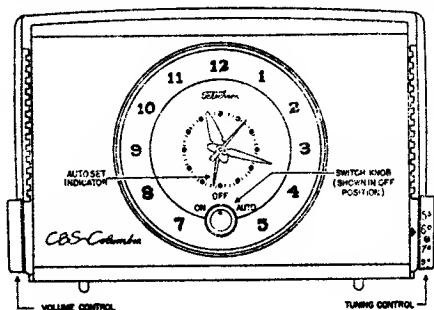

78008421

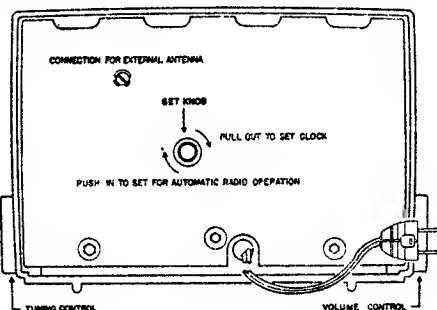

I.F. 456 KC.

Parts List

Capacitors

- C1 Variabla Capacitor
- C2 Paper .05 mfd. 200V ± 20%
- C3, C12 Ceramic Tubular 220 mfd. 500V ± 20%
- C4 Paper .01 mfd. 400V ± 20%
- C5 Paper .02 mfd. 400V ± 20%
- C6 Paper .1 mfd. 400V ± 20%
- C7 Paper .05 mfd. 400V ± 20%
- C8 Electrolytic 50-30 mfd. 150V

Resistors

- R1 Carbon 22K ohm ½W ± 10%
- R2, R6 Carbon 150 ohm ½W ± 10%
- R3 Carbon 3.3 Megohm ½W ± 10%
- R4 Control, Volume 500K ohm
- R5 Carbon 4.7 Megohm ½W ± 10%
- R7 Carbon 1800 ohm 1W ± 10%
- R10 Carbon 33 ohm ½W ± 10%
- R11 Carbon 1.0 Megohm ½W ± 10%

NOTE:
C9-C11 = 250MMF
C10 = .01
R8-R9 = 500K

CAPACITY VALUES IN MFD
RESISTOR VALUES IN OHMS
UNLESS OTHERWISE SPECIFIED.

MANUAL OF 1954 MOST-OFTEN-NEEDED RADIO DIAGRAMS

CBS Columbia

Model 535

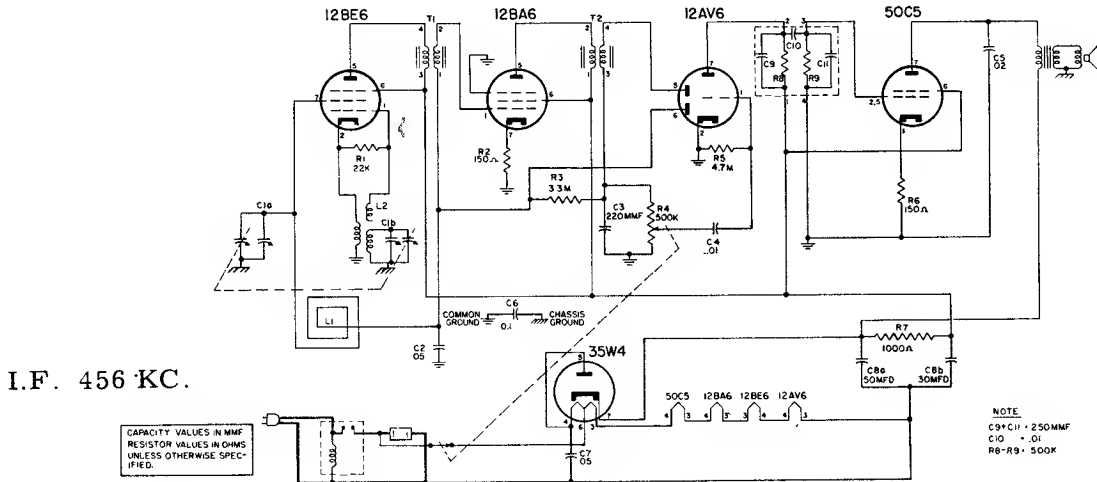

3-Way Portable Radio Chassis 4P1

MODELS 5220-Sand; 5220-Maroon; 5220-Gray; 5220-Green

Capacitors

C1A, B	24000011	Variable Capacitor
C2	23064900	Ceramic Disc, 220 mmfd. 500V ± 20%
C3	22025740	Paper, .05 mfd. 200V ± 20%
C4	23065920	Ceramic Disc, .01 mfd. 300V ± 20%
C5	23065570	Ceramic Disc, .001 mfd. 500V ± 10%
C11	23066000	Ceramic Disc, .01 mfd. 600V ± 20%
C12A, B, C	21000011	Electrolytic 60-60 mfd. 150V, 100 mfd. 25V
C13	23002660	Ceramic Tubular, 220 mmfd. 500V ± 20%
C14	22017240	Molded, .05 mfd. 400V ± 20%
C15, 17	22026280	Paper, .1 mfd. 400V ± 20%
C16	22025780	Paper, .1 mfd. 200V ± 20%

Resistors

R1	30104230	Fixed Composition, 100K Ohm ½W ± 10%
R2	30472230	Fixed Composition, 4.7K Ohm ½W ± 10%
R3	30106230	Fixed Composition, 10 Megohm ½W ± 10%
R4	36000982	Volume Control, 2 Megohm W/SW
R9	33000061	Wirewound, 75 ohm 2W ± 10% (Flexohm)
R10	31000011	Wirewound, 2250 ohm-Tapped 750 ohm
R11	30151130	Fixed Composition, 150 ohm ½W ± 5%
R12	30681130	Fixed Composition, 680 ohm ½W ± 5%
R13	30105230	Fixed Composition, 1 Megohm ½W ± 10%
R14	30335230	Fixed Composition, 3.3 Megohm ½W ± 10%
R15	30274230	Fixed Composition, 270K ohm ½W ± 10%

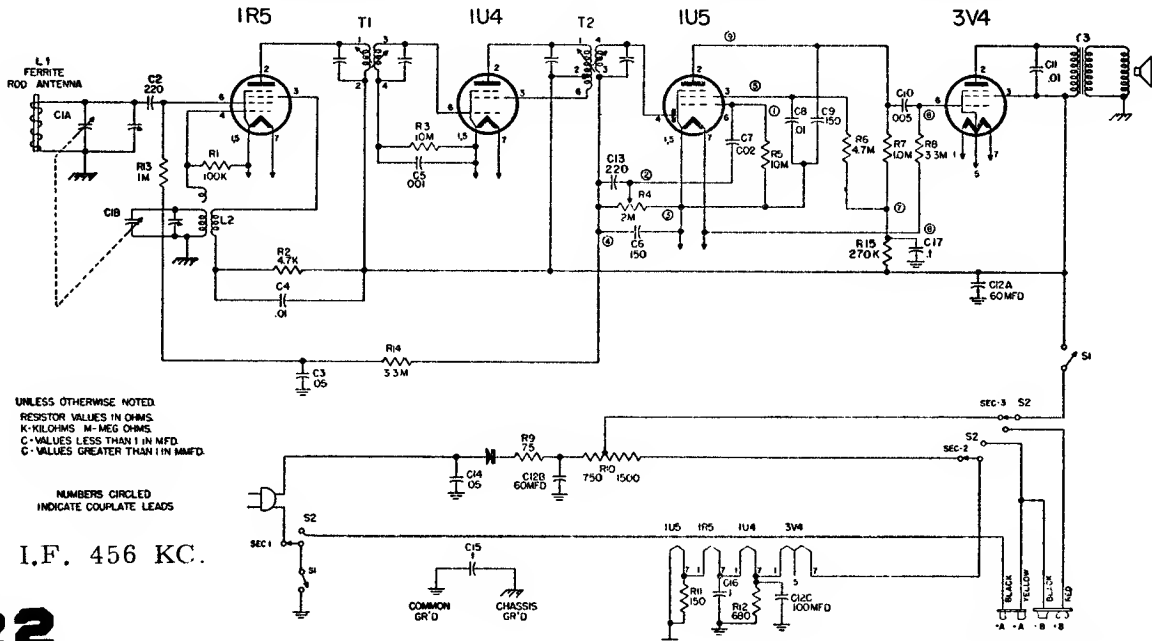

MANUAL OF 1954 MOST-OFTEN-NEEDED RADIO DIAGRAMS

CROSLEY

CHASSIS 25F

Models F-25MN, F-25BE, F-25BK, F-25GN

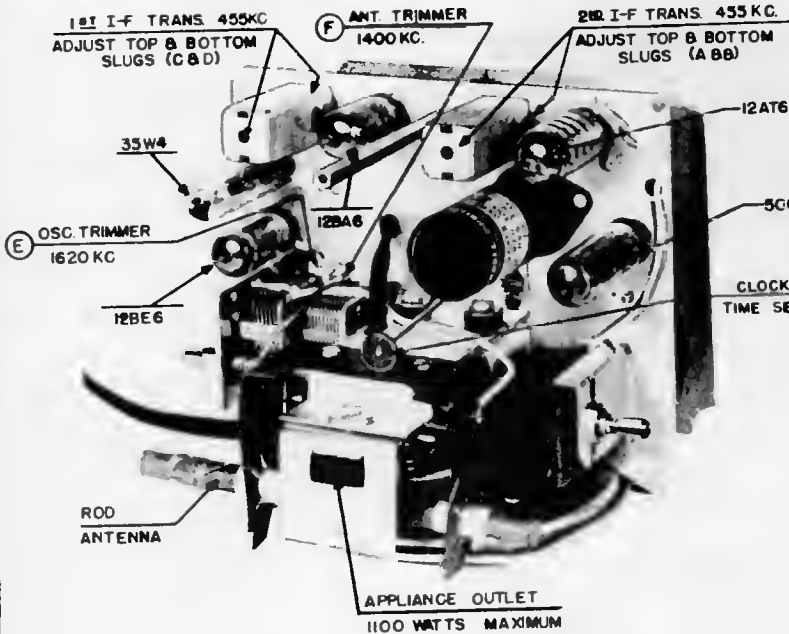

SOCKET VOLTAGE CHART

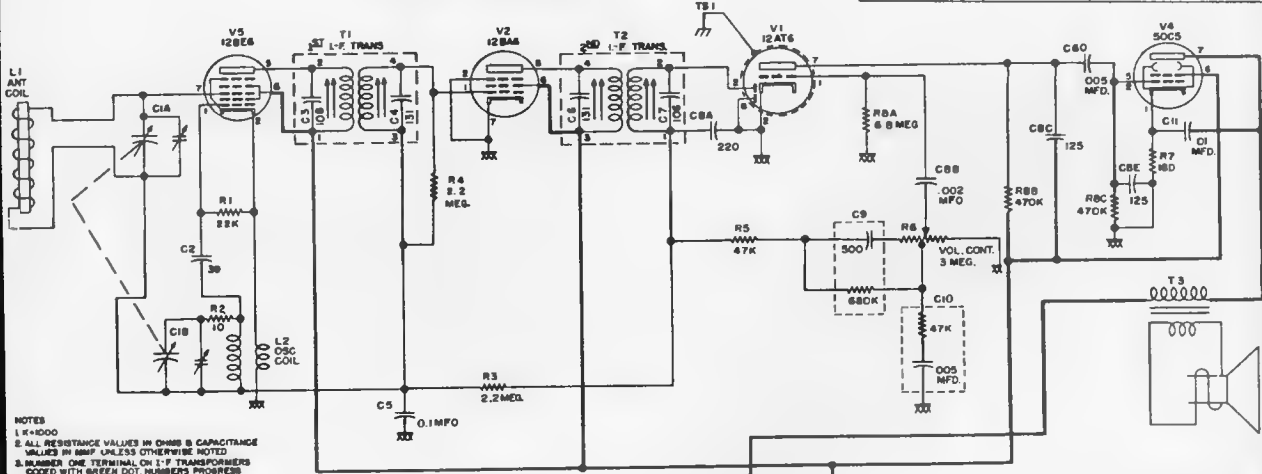
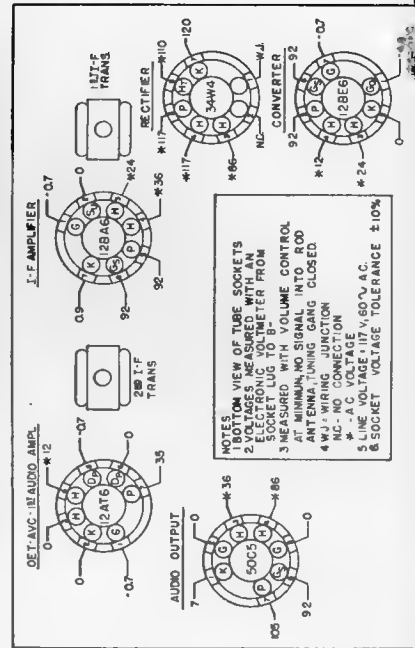

- NOTES:
 1. K=1000
 2. ALL RESISTANCE VALUES IN OHMS & CAPACITANCE VALUES IN PPMF UNLESS OTHERWISE NOTED
 3. NUMBER ONE TERMINAL ON I-F TRANSFORMERS CODED WITH GREEN DOT, NUMBERS PROGRESS CLOCKWISE
 4. I-F = 455 KC
 5. CHASSIS
 6. COMMON WIRING
 SWITCH SW1 IS USED TO CONTROL OPERATION OF THE RADIO AND OUTLET AS FOLLOWS:
 A. MANUALLY BY SETTING THE OPERATION KNOB AT "RADIO ON OR OFF"
 B. AUTOMATIC ALARM AND RADIO START POWER ON BY PRESET OF ALARM CONTROLS WITH THE OPERATION KNOB SET AT "RADIO ALARM"
 C. AUTOMATIC STOP-POWER OFF 1 AFTER NOT MORE THAN A 90 MINUTE INTERVAL BY SETTING THE SLEEP CONTROL WITH THE OPERATION KNOB AT OFF

DIAGRAM SYMBOL VIEWED FROM STAMP

R8A	6.8 MEG	R10	47
R8B	470K	R11	1200
R9	470R	C14B	100MFD.
C18	100MFD.	C12	.047 MFD.
C19	100MFD.	C13	0.66 MFD.
C20	100MFD.	C01	
C21	100MFD.	C11	DI MFD.
C22	100MFD.	C10	0.05 MFD.
C23	100MFD.	C9	3 MEG.
C24	100MFD.	C8	500
C25	100MFD.	C7	0.05 MFD.
C26	100MFD.	C6	0.05 MFD.
C27	100MFD.	C5	0.1 MFD.
C28	100MFD.	C4	0.05 MFD.
C29	100MFD.	C3	0.05 MFD.
C30	100MFD.	C2	30
C31	100MFD.	C1	10

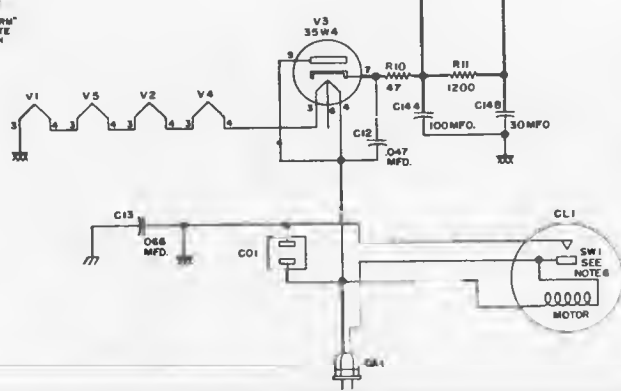

MANUAL OF 1954 MOST-OFTEN-NEEDED RADIO DIAGRAMS

CROSLEY

CHASSIS 120F
Model F-120BN

FREQUENCY RANGE: 540 to 1600 kc.
INTERMEDIATE FREQUENCY: 455 kc.

SOCKET VOLTAGE CHART

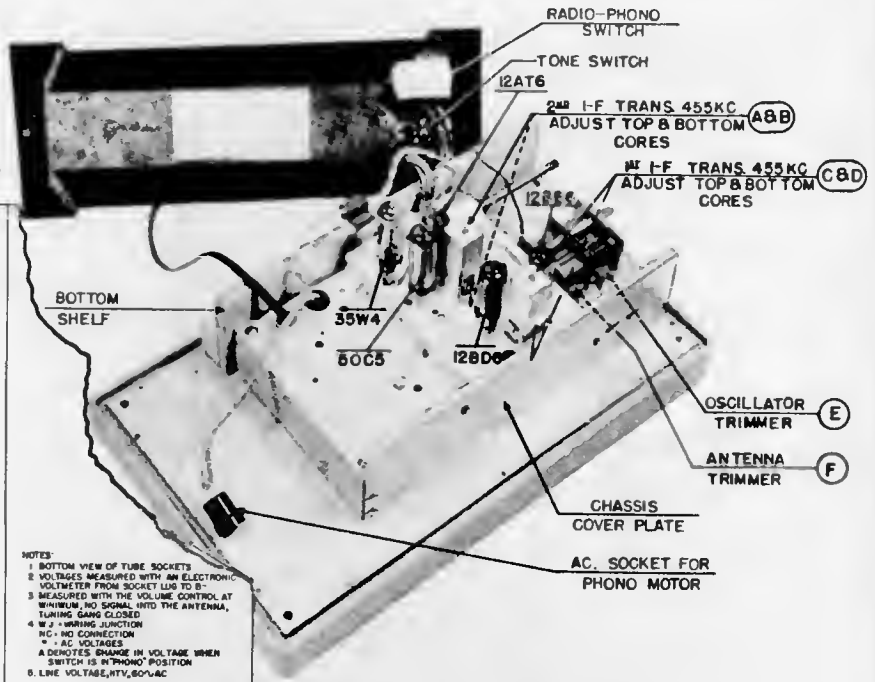
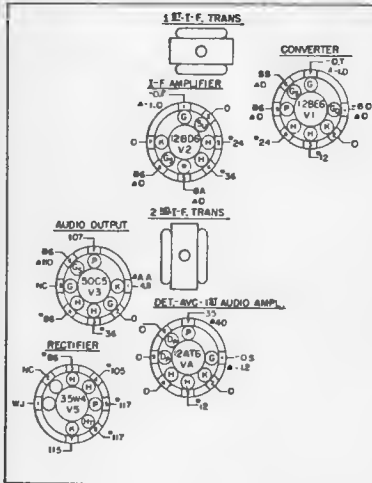

NOTES:
1. BOTTOM VIEW OF TUBE SOCKETS
2. VOLTAGES MEASURED WITH AN ELECTRONIC VOLTMETER FROM SOCKET LUG TO B-
3. MEASURED WITH THE VOLUME CONTROL AT MINIMUM, NO SIGNAL INTO THE ANTENNA, TUNING GAINS CLOSED
4. W-P = WARMING JUNCTION
NC = NO CONNECTION
+ = AC VOLTAGES
A DENOTES CHANGE IN VOLTAGE WHEN SWITCH IS IN "PHONO" POSITION
5. LINE VOLTAGE, RTV, 80VAC

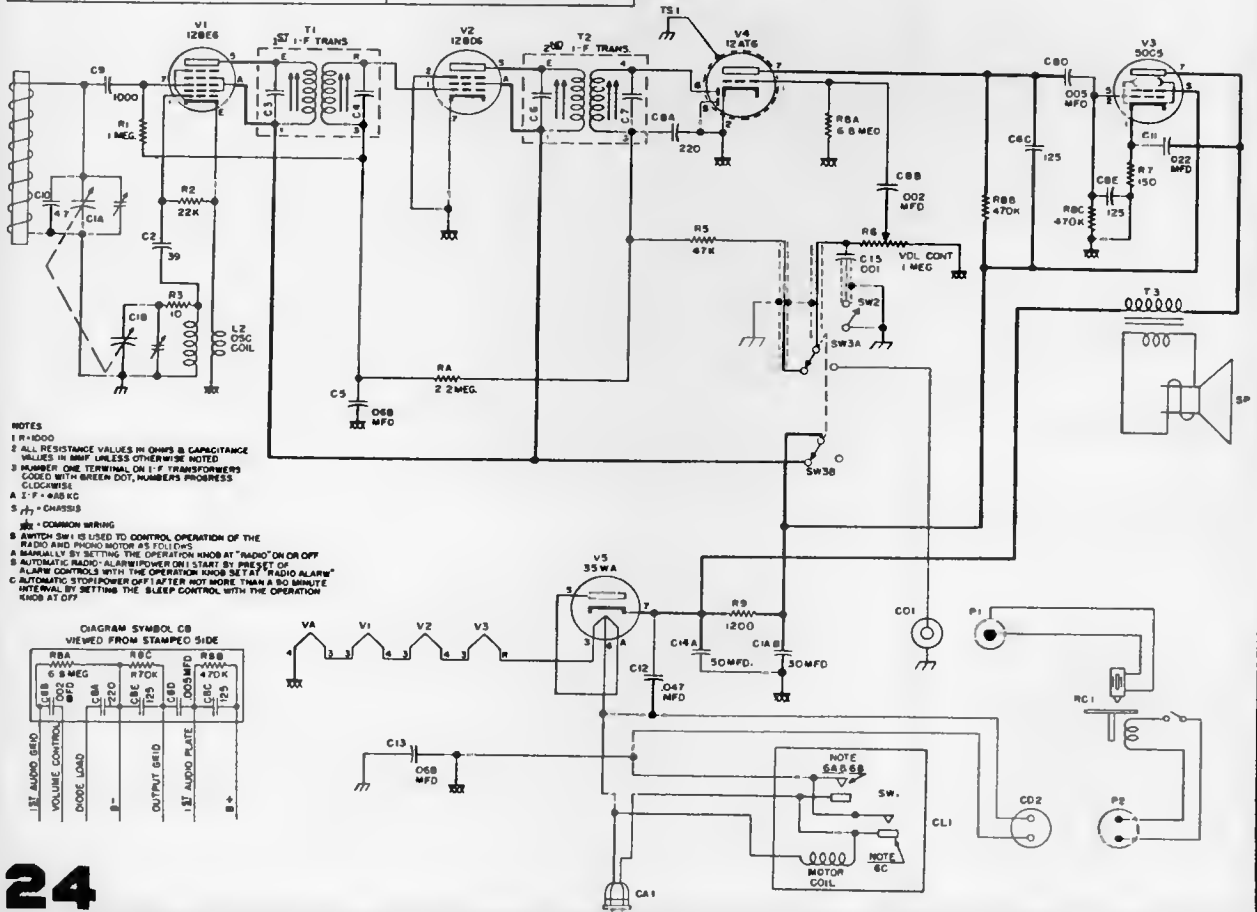

NOTES:
1. R = 1000
2. ALL RESISTANCE VALUES IN OHMS & CAPACITANCE VALUES IN MMF UNLESS OTHERWISE NOTED
3. NUMBER ONE TERMINAL ON I-F TRANSFORMERS CODED WITH GREEN DOT, NUMBERS PROGRESS CLOCKWISE
A I-F = 455 KC
S-P = CHASSIS
SW = COMMON SWING
4. SWITCH SW1 IS USED TO CONTROL OPERATION OF THE RADIO AND PHONO MOTOR AS FOLLOWS:
A. MANUALLY BY SETTING THE OPERATION KNOB AT "RADIO" ON OR OFF
B. AUTOMATIC RADIO-ALARM POWER ON START BY PRESET OF ALARM CONTROL WITH THE OPERATION KNOB SET AT "RADIO ALARM"
C. AUTOMATIC STOP POWER OFF AFTER NOT MORE THAN A 90 MINUTE INTERVAL BY SETTING THE SLEEP CONTROL WITH THE OPERATION KNOB AT OFF

DIAGRAM SYMBOL C8 VIEWED FROM STAMPED SIDE

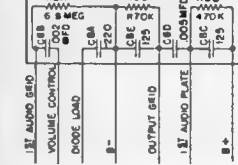

MANUAL OF 1954 MOST-OFTEN-NEEDED RADIO DIAGRAMS

CROSLEY

CHASSIS 115F
 MODELS: F115MN, F115GN, F115TN

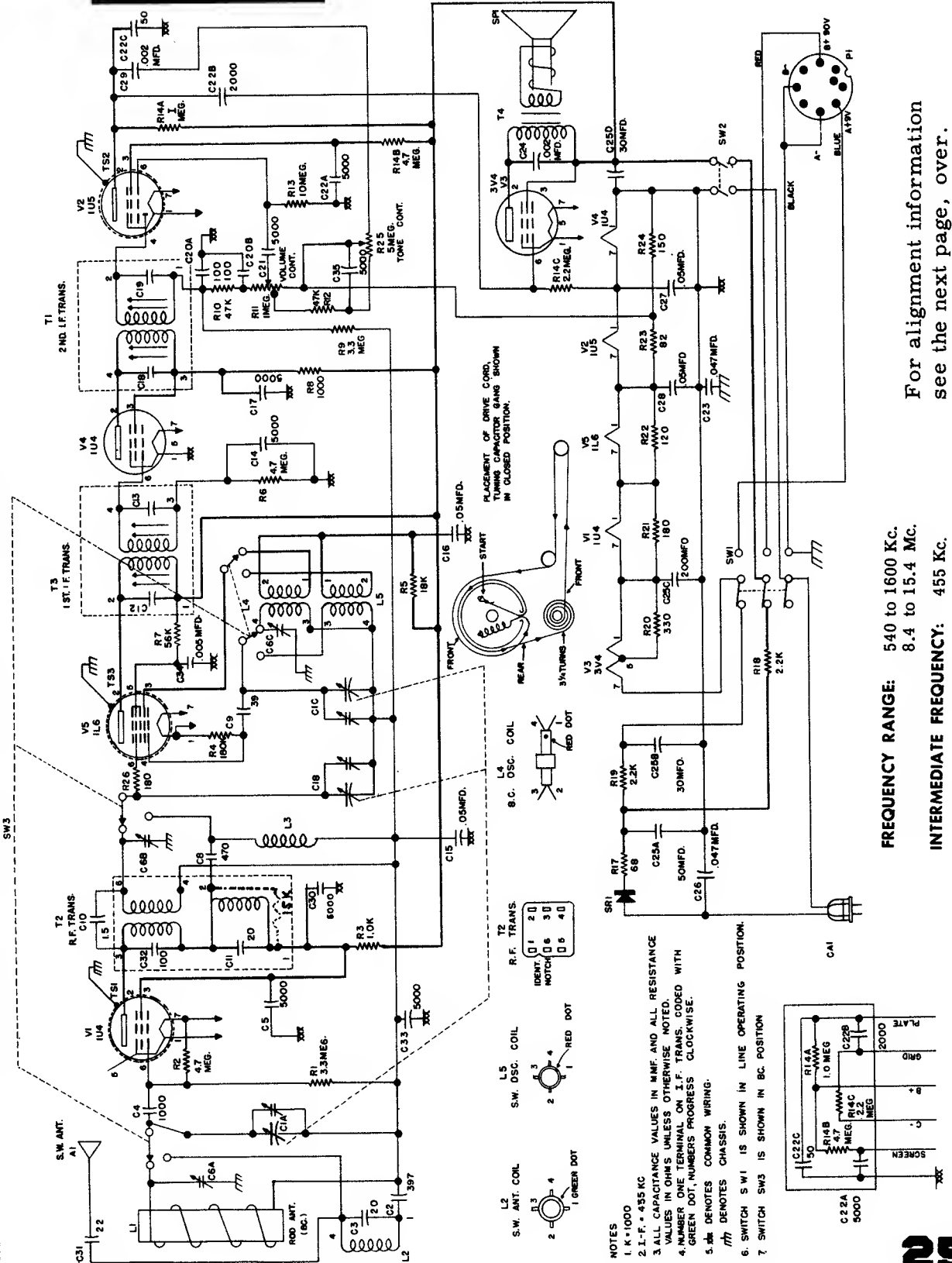

For alignment information
 see the next page, over.

FREQUENCY RANGE: 540 to 1600 Kc.
 8.4 to 15.4 Mc.
 INTERMEDIATE FREQUENCY: 455 Kc.

- NOTES
1. K=1000
 2. I.F. = 455 KC
 3. ALL CAPACITANCE VALUES IN M.M.F. AND ALL RESISTANCE VALUES IN OHMS UNLESS OTHERWISE NOTED.
 4. NUMBER ONE TERMINAL ON I.F. TRANS. CODED WITH GREEN DOT, NUMBERS PROGRESS CLOCKWISE.
 5. Δ DENOTES COMMON WIRING.
 6. Δ DENOTES CHASSIS.
 7. SWITCH SW1 IS SHOWN IN LINE OPERATING POSITION.
 8. SWITCH SW3 IS SHOWN IN BC POSITION.

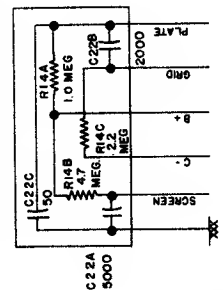

MANUAL OF 1954 MOST-OFTEN-NEEDED RADIO DIAGRAMS

CROSLEY Chassis 115F, Models F115GN, F115MN, and F115TN
(For circuit diagram see preceding page)

ALIGNMENT CHART

SEQUENCE	SIGNAL GENERATOR OUTPUT			POSITION OF		ADJUST FOR MAX. OUTPUT	REMARKS
	FREQUENCY	IN SERIES WITH	TO	RANGE SWITCH	TUNING DIAL		
1	455Kc	.05 mfd	Note 1	S.W.	Gang open	A,B,C,D	Note 1
	Repeat adjustments to obtain maximum output						
2	15.7Mc	Dummy	S.W. Antenna	S.W.	Gang open	E	Note 3 & 6
3	15Mc	Dummy	S.W. Antenna	S.W.	Tune in Sig.	F,G	Note 3 & 4
4	1620Kc	Radiated	B.C. Antenna	B.C.	Gang open	H	Note 5
5	1400Kc	Radiated	B.C. Antenna	B.C.	Tune in Sig.	I,J	Note 5

1. Low side of generator returned to B- on electrolytic capacitor, high side of generator connected to stator of gang capacitor, center section.
2. After aligning I-F Transformers, replace bottom cover of chassis.
3. Low side of generator returned to chassis, high side of generator connected to shortwave antenna through dummy.
4. Peak center trimmer (mixer section) and rear trimmer (antenna section by rocking gang to secure maximum output.)
5. Radiate signal from generator to rod antenna by placing wire attached to high side of generator close to the rod antenna opposite to the end that is wired to the gang stator.
6. Do not align the shortwave oscillator to image at 14 megacycles.

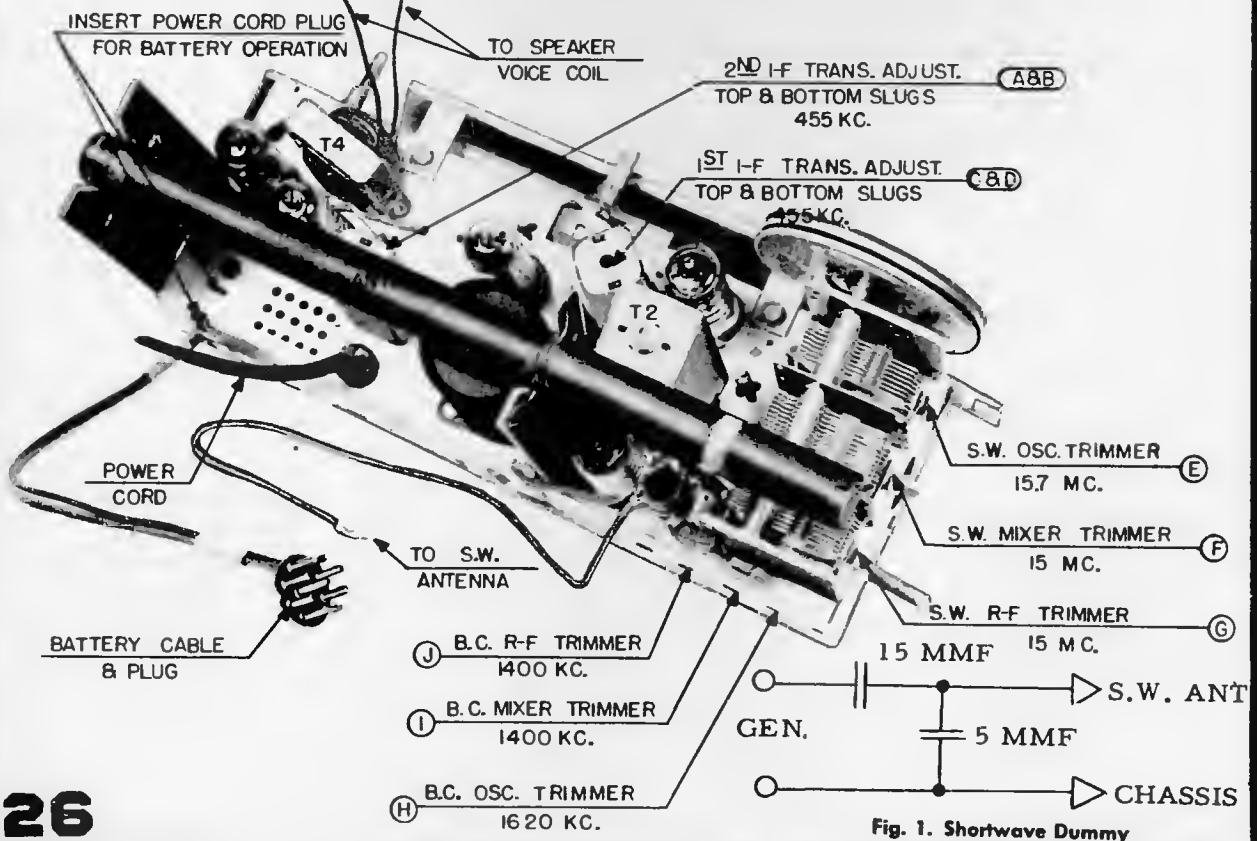
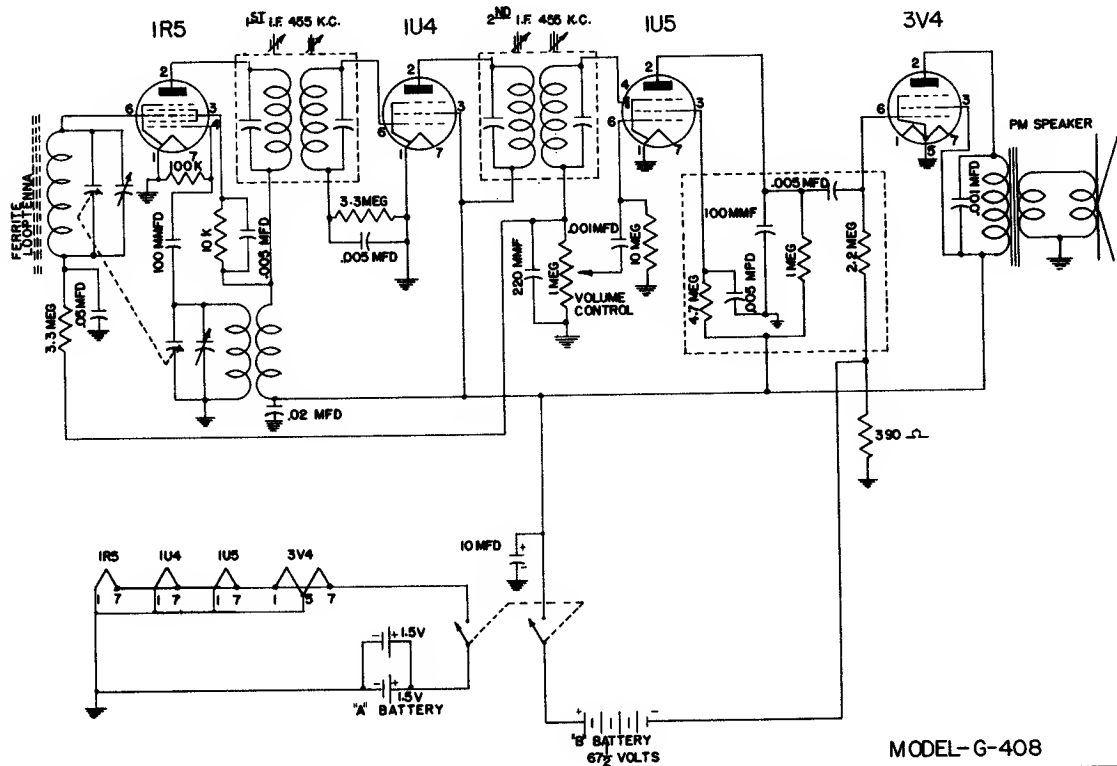

Fig. 1. Shortwave Dummy

MANUAL OF 1954 MOST-OFTEN-NEEDED RADIO DIAGRAMS

DeWald Radio Manufacturing Corp.

Model G-408



MODEL-G-408

DeWald Radio Manufacturing Corp.

Model H-527

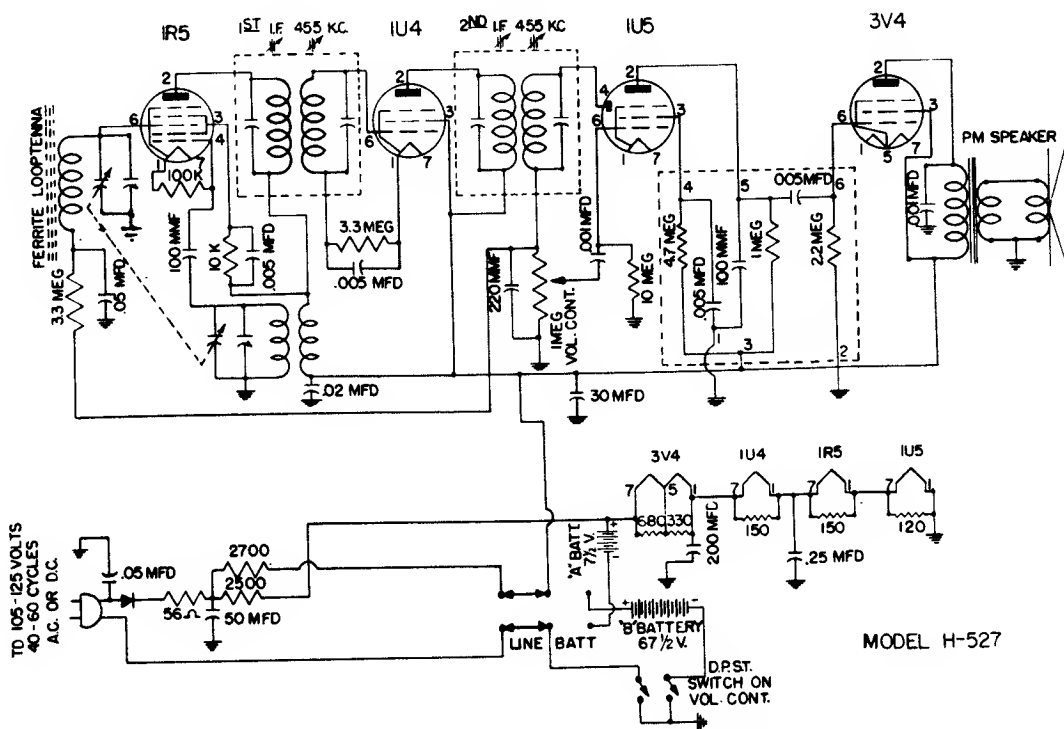

MODEL H-527

MANUAL OF 1954 MOST-OFTEN-NEEDED RADIO DIAGRAMS

DeWald Radio Manufacturing Corp.

Model H-528

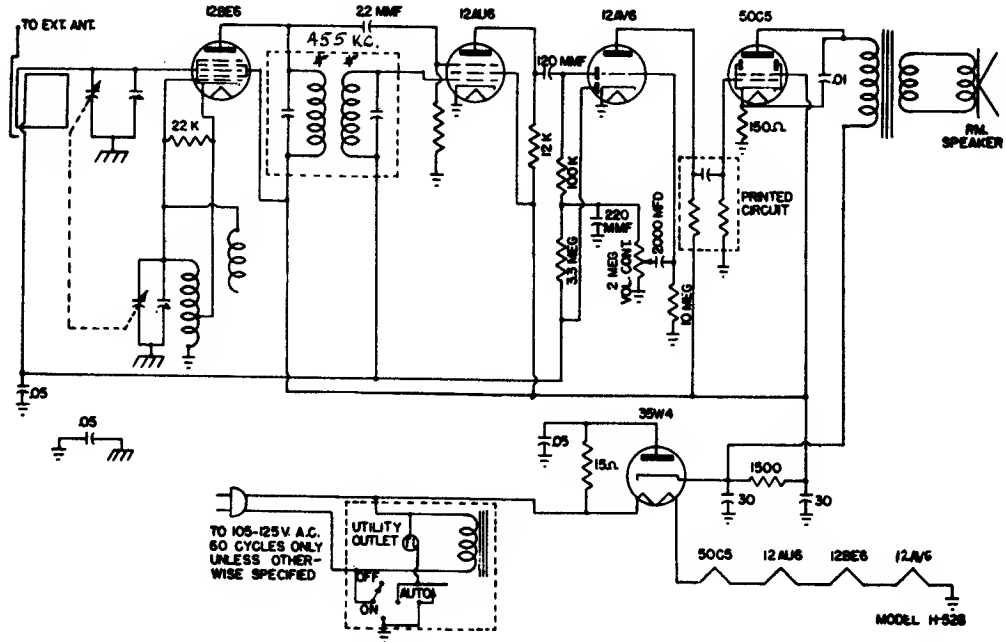

DeWald Radio Manufacturing Corp.

Model H-533

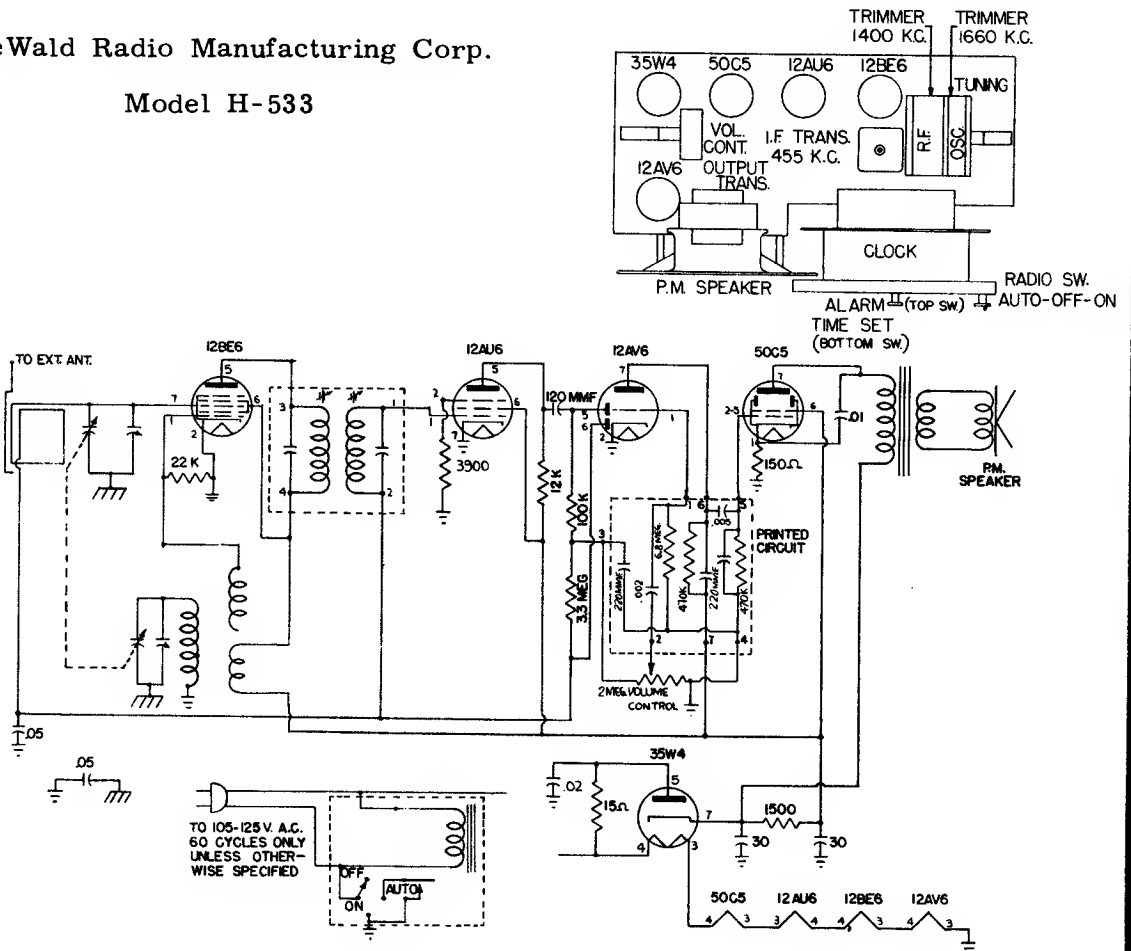

MANUAL OF 1954 MOST-OFTEN-NEEDED RADIO DIAGRAMS

EMERSON RADIO

MODEL 745B - 754D

CHASSIS 120176-B

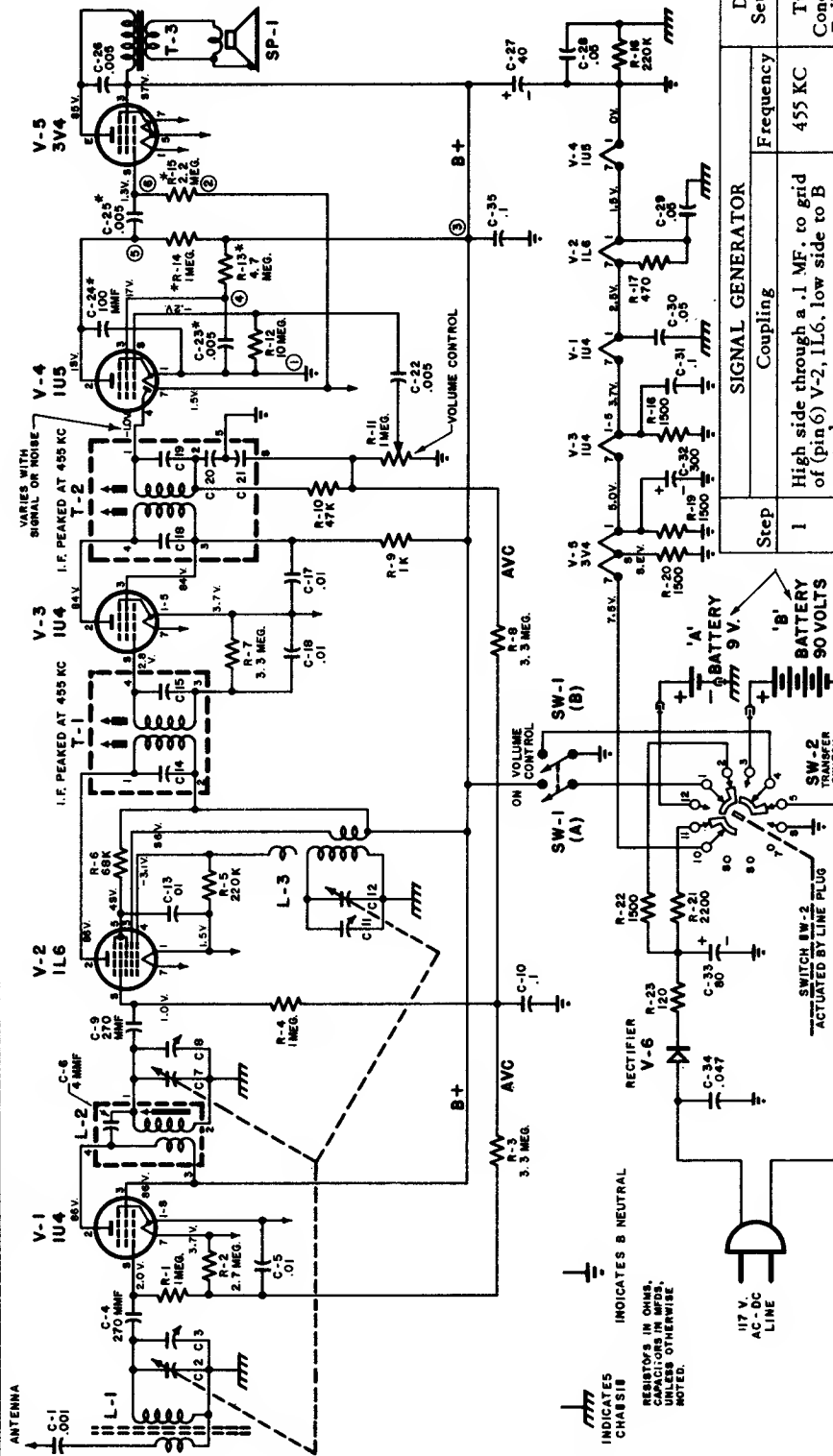

Step	SIGNAL GENERATOR		Adjust
	Coupling	Frequency	
1	High side through a .1 MF. to grid of (pin 6) V-2, 1L6, low side to B neutral.	455 KC	T-2, T-1 Top and Bottom
2	Form loop of several turns and radiate signal into receiver. Keep this loop perpendicular and about 20 in. from center of bar loop ant. in set.	1640 KC	C-11 (BC, OSC.)
3	"	1420 KC	C-8 (BC, RF) C-3 (Ant.)
4	"	530 KC	L-3 (Osc.) L-2 (R.F.)
5	Recheck steps 2 to 4 and retune if necessary		

* Underside chassis cover must be secured in place when performing steps 2 to 5

⊙ REFERS TO TERMINAL NUMBERS ON THE COUPLATE
 * INDICATES COMPONENTS ARE PART OF COUPLATE (PART NO. 925027)

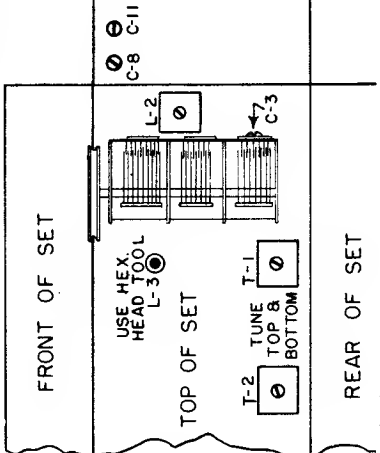
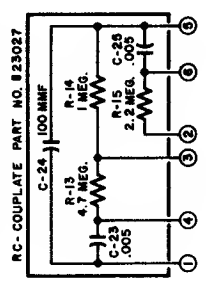

MANUAL OF 1954 MOST-OFTEN-NEEDED RADIO DIAGRAMS

Emerson Radio

MODEL - 746B

CHASSIS - 120177-B

Continued on the adjacent page, at right.

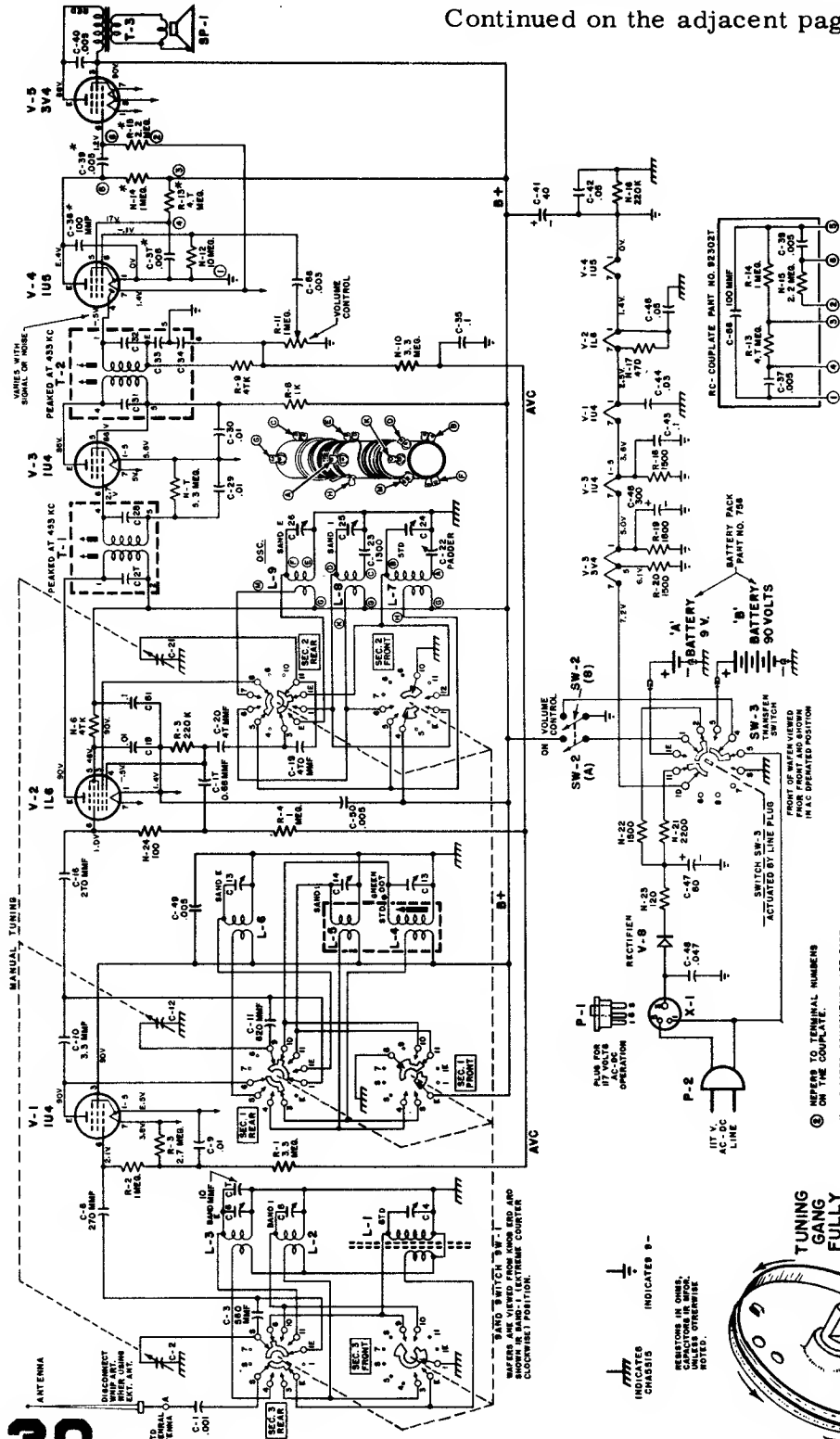
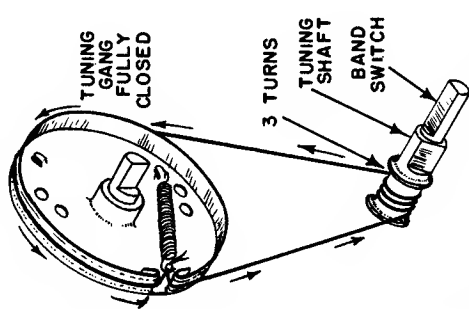

Figure 1. Schematic Diagram, Chassis 120177-B

CONDITIONS FOR VOLTAGE AND RESISTANCE ANALYSIS

1. Voltage readings are d.c. volts, resistance readings are ohms, with values measured from socket pin to B neutral.
2. Voltage readings measured for 117 volt a.c. line operation. All measurements made with voltohmmyst, or equivalent.
3. No signal applied and band switch in BC position, for voltage and resistance measurements.
4. Nominal tolerance on component values makes possible a variation of $\pm 15\%$ in readings.
5. Resistance measurements taken with set turned "On" and line plug removed from wall socket (do not insert in chassis transfer switch SW-3).



Ⓢ REFERS TO TERMINAL NUMBERS ON THE COMPLATE.
 * INDICATES COMPONENTS ARE PART OF COMPLATE (PART NO. 8320ST).

INDICATED CHASSIS COMPONENTS IN WIRE, UNLESS OTHERWISE NOTED.

MANUAL OF 1954 MOST-OFTEN-NEEDED RADIO DIAGRAMS EMERSON RADIO AND PHONOGRAPH CORPORATION

Model 746B, Chassis 120177-B (Continued from the adjacent page, at left)

ALIGNMENT PROCEDURE

1. Volume control should be set at maximum position. The output of the signal generator should be no higher than necessary to obtain an output reading. Attenuate the signal input as alignment proceeds.
2. Use isolation transformer if available; otherwise when connecting low side directly to B neutral use a .1 mfd. condenser in series with low side of signal generator.
3. Refer to figure 3 for location of alignment trimmers.
4. For SW alignment of the receiver, maintain the telescoping antenna closed.

Step	SIGNAL GENERATOR		Band Switch Position	Dial Setting	Adjust	Procedure
	Coupling	Frequency				
1	High side thru 0.1 mfd. to grid (Pin No.6) V-2, 1L6. Low side to B neutral (See note 2 above).	455 KC	BC	Tuning Cond Fully open	T-2, T-1 Top and Bottom	Peak for maximum output.
2	Form loop of several turns and radiate signal into receiver.	1640 KC	BC	"	C-24 (BC OSC.)	* "
3	"	1420 KC	BC	Tune for maximum output	C-4 (BC Ant.) C-13 BC (RF)	* "
4	"	530 KC	BC	Tuning Cond. Fully Closed	C-22 (BC pad-der L-4 (BC. RF)	* "
Recheck steps 2 to 4 and retune if necessary						
5	High side thru a 200 MMF to external antenna terminal, low side to chassis.	6.5 MC.	SW-1	Tuning Cond Fully open	C-25 OSC.	Peak for maximum output *
6	"	5.5 MC	SW-1	Tune for max. output	C-5 (Antenna) C-14,(RF)	* "
7	"	22.0 MC	SW-2	Tuning Cond Fully open	C-26 OSC.	* "
8	"	21.5 MC	SW-2	Tune for max. output	C-6 (Antenna) C-15,(RF)	Rock dial each side of 21.5 MC. while adjusting C-6 and then C-15 for maximum response *

* Note underside chassis cover must be secured in place when performing steps 2 to 8, otherwise tuner tracking will shift.

RESISTANCE READINGS FOR CHASSIS 120177-B

SYMBOL	TUBE	PIN 1	PIN 2	PIN 3	PIN 4	PIN 5	PIN 6	PIN 7
V-1	1U4	25 ~	4 K	4 K	2 MEG.	N.C.	3 MEG.	40 ~
V-2	1L6	14 ~	4 K	4 K	210 K	50 K	3.5 MEG.	25 ~
V-3	1U4	40 ~	5 K	5 K	N.C.	40 ~	3 MEG.	55 ~
V-4	1U5	0 ~	900 K	4.2 MEG.	900 K	4 K	10 MEG.	14 ~
V-5	3V4	55 ~	4 K	4 K	0	65 ~	2.2 MEG.	75 ~
V-6	Selenium Rectifier							

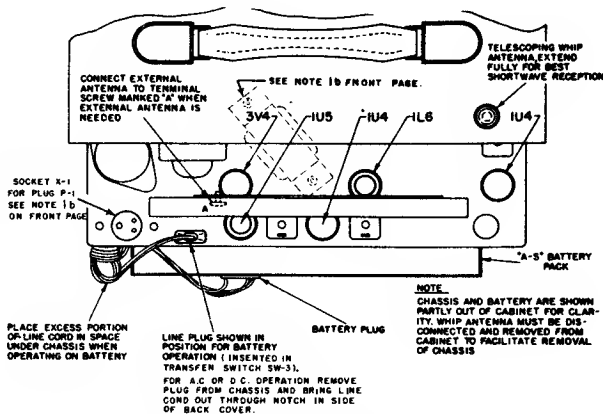

Figure 2. Tube and Battery Location Diagram

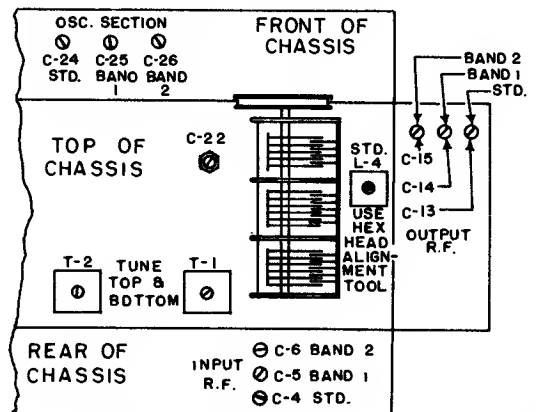

Figure 3. Alignment Point Drawing

MANUAL OF 1954 MOST-OFTEN-NEEDED RADIO DIAGRAMS

Emerson

MODEL 747

CHASSIS 120178

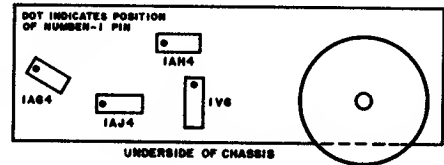

ALIGNMENT INSTRUCTIONS

NOTE: C-5, C-2, and L-2 must be adjusted with the chassis and batteries in the cabinet. C-5 and C-2 can be adjusted by removing a small plate on the side of the cabinet by pressing it out from the inside. See Fig. 3.

	DUMMY ANTENNA	SIGNAL GENERATOR COUPLING	SIGNAL GENERATOR FREQUENCY	RADIO DIAL SETTING	OUTPUT METER	ADJUST	REMARKS
1	.1 mfd.	High side to pin 3 (grid) of IV6. Low side to chassis.	455 KC.	Tuning condenser fully open.	Across voice coil	T2 and T1	Adjust top and bottom of each for maximum output.
2		Use a loop set perpendicular and about 20" from center of bar loop ant. in set.	1640 KC.	Tuning condenser fully open.	Across voice coil	C-5 (osc. trimmer)	Fashion loop of several turns of wire and radiate signal into bar loop of receiver. Adjust for maximum output.
3		"	1400 KC.	Tune for maximum output.	Across voice coil.	C-2 (Ant. trimmer)	Adjust for maximum output.
4		"	600 KC.	Tuning condenser set for 600 KC.	Across voice coil.	Osc. slug in L-2	Rock the variable cond. each side of 600 KC while adj. osc. slug for maximum response.
5		"	1640 KC.	Tuning condenser fully open.	"	C-5 Osc. trimmer	If readjustment is necessary repeat steps 2 to 4 until no further improvement is noted.

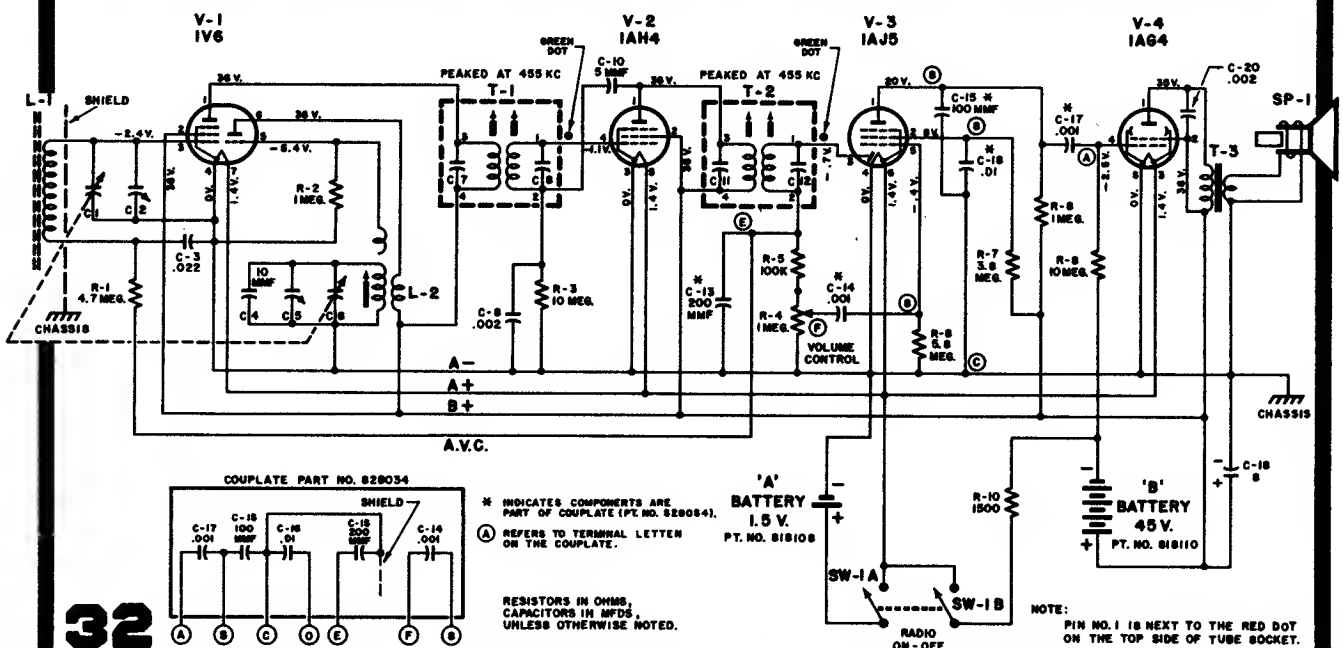

MANUAL OF 1954 MOST-OFTEN-NEEDED RADIO DIAGRAMS

EMERSON RADIO AND PHONOGRAPH

MODEL - 783B
CHASSIS - 120200-B

ALIGNMENT INSTRUCTIONS

Use isolation transformer if available. If not, connect a .1 mfd. condenser in series with low side of signal generator and B neutral.

STEP	DUMMY ANTENNA	SIGNAL GENERATOR COUPLING	SIGNAL GENERATOR FREQUENCY	RADIO DIAL SETTING	OUTPUT METER	ADJUST	REMARKS
1	.1 mfd.	High side to grid (pin 7) of V1 (12BE6). Low side to B neutral	455 KC	Variable condenser fully open.	Across voice coil.	T2, T1 (A3, A4, A1, A2)	Adjust for maximum output. If isolation transformer is not used, reduce dummy ant. to .001 mfd. to reduce hum modulation.
2		Form loop of several turns and radiate signal into receiver	1620 KC	"	Across voice coil.	Trimmer C-4 (Osc.)	Adjust for maximum output.
3		"	1400 KC	Tune for maximum output.	Across voice coil.	Trimmer C-2 (Ant.)	Adjust for maximum output.

RESISTANCE READINGS FOR CHASSIS 120200-B

SYMBOL	TUBE	PIN 1	PIN 2	PIN 3	PIN 4	PIN 5	PIN 6	PIN 7
V-1	12BE6	22K [*]	0	12	24	1500 [*]	1500 [*]	4.0 meg
V-2	12BA6	13 [~]	0	24	36	1500 [*]	1500 [*]	120 [~]
V-3	12AT6	6.8 meg	0	0	12 [~]	680K	0	470K [*]
V-4	50C5	150 [~]	492K	36 [~]	90 [~]	492K	1500 [*]	210 [*]
V-5	35W4	NC	NC	90 [~]	120 [~]	135 [~]	110 [~]	0 [*]

* Resistances measured to Pin 7 of Rectifier 35W4 (B+).

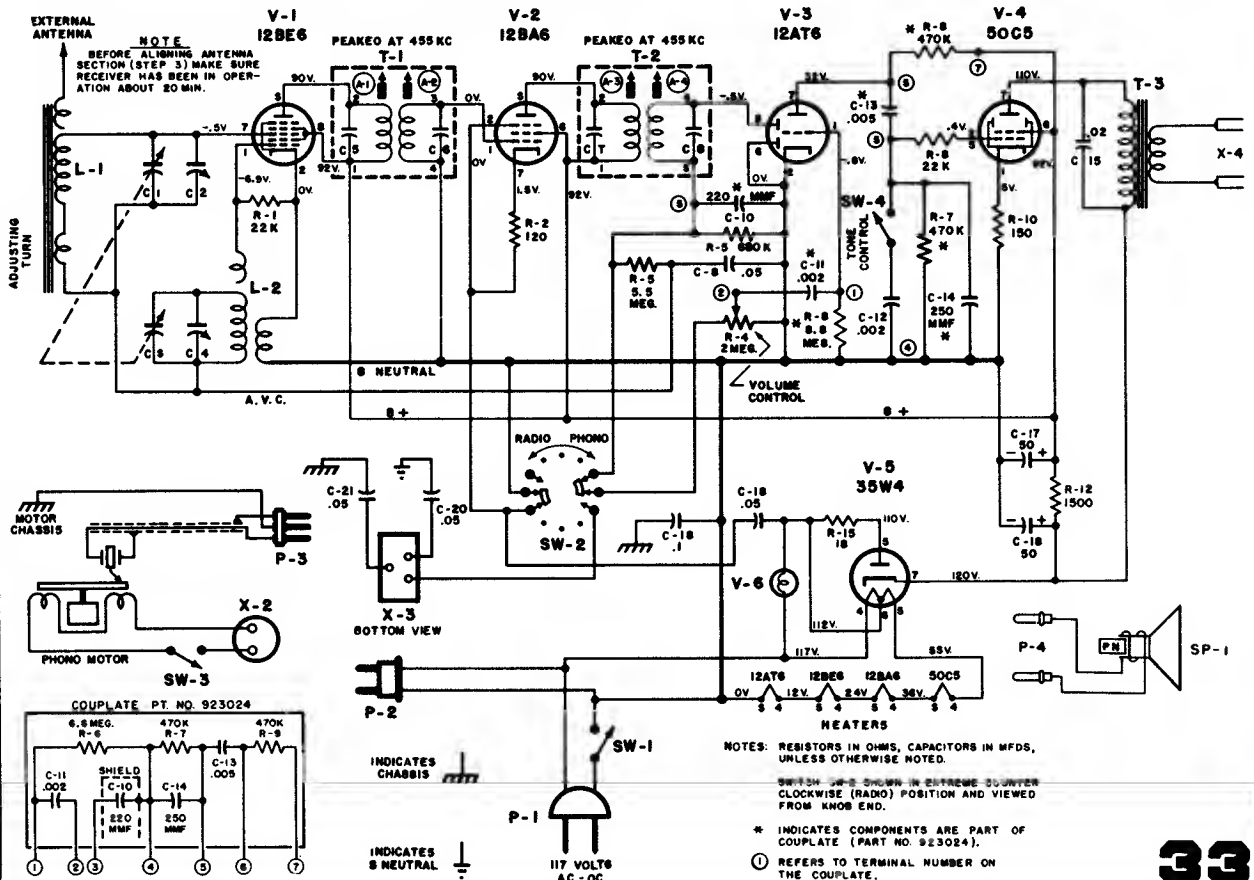

MANUAL OF 1954 MOST-OFTEN-NEEDED RADIO DIAGRAMS

EMERSON RADIO

MODEL - 778B

CHASSIS - 120199-B

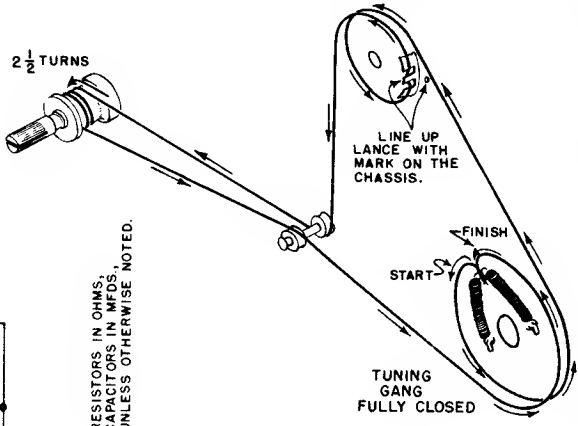
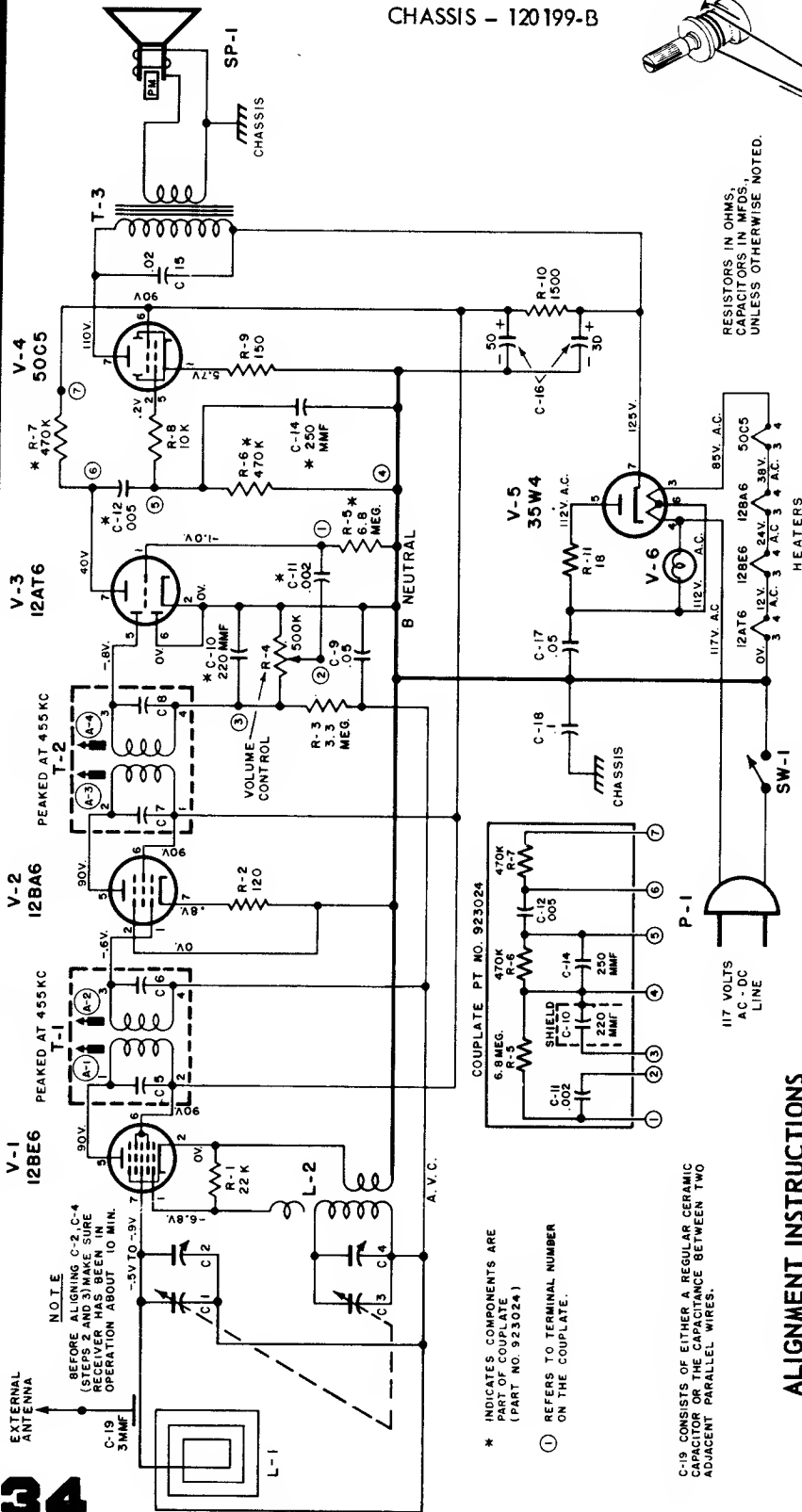

ALIGNMENT INSTRUCTIONS

STEP	DUMMY ANTENNA	SIGNAL GENERATOR COUPLING	SIGNAL GENERATOR FREQUENCY	RADIO DIAL SETTING	OUTPUT METER	ADJUST	REMARKS
1	.005 mfd.	High side to grid (pin 7) Low side to V1 (I2BE6).	455 KC	Variable condenser fully open.	Across voice coil.	T2, T1 (A3, A4, A1, A2)	Adjust for maximum output.
2		Form loop of several turns and radiate signal into receiver	1620 KC	"	Across voice coil.	Trimmer C-4 (Osc.)	Adjust for maximum output.
3		"	1400 KC	Tune for maximum output.	Across voice coil.	Trimmer C-2 (Ant.)	Adjust for maximum output.

MANUAL OF 1954 MOST-OFTEN-NEEDED RADIO DIAGRAMS

EMERSON RADIO & PHONOGRAPH

MODEL - 789B

CHASSIS - 120207-B

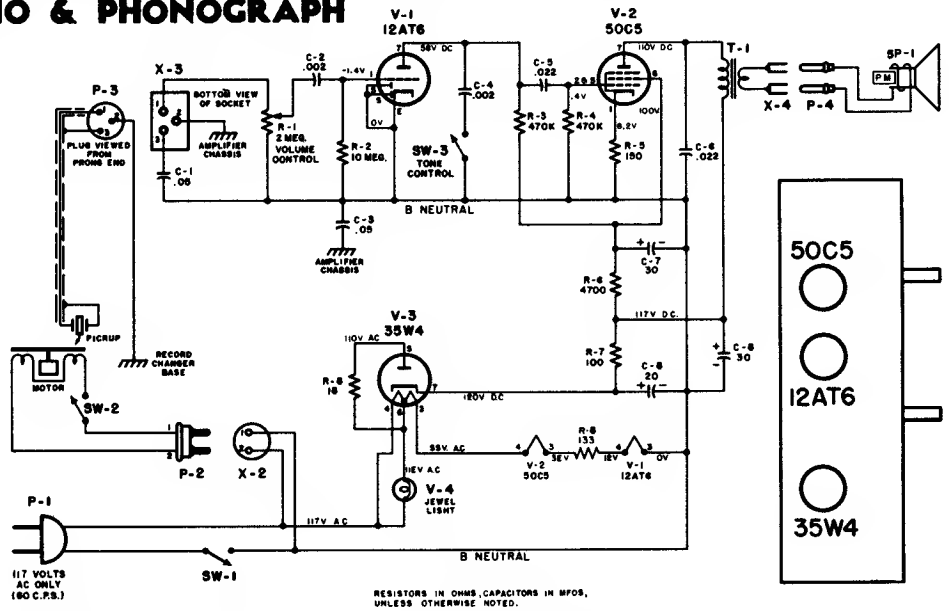

RESISTANCE READINGS FOR CHASSIS 120207-B

SYMBOL	TUBE	PIN 1	PIN 2	PIN 3	PIN 4	PIN 5	PIN 6	PIN 7
V-1	12AT6	10 MEG	0 ~	0 ~	12 ~	0 ~	0 ~	*470K ~
V-2	50C5	150 ~	470 ~	145 ~	185 ~	470 ~	*4700 ~	*250 ~
V-3	35W4	2 MEG †	2 MEG †	185 ~	205 ~	220 ~	205 ~	2 MEG †

* Resistance measured to Pin 7 of rectifier 35W4 (B+).

† Measured with VTVM Rx10,000 when using other meters allow reading to settle (1 min.)

Emerson Radio and Phonograph *** Models 806 and 807

RESISTANCE READINGS

SYMBOL	TUBE	PIN 1	PIN 2	PIN 3	PIN 4	PIN 5	PIN 6	PIN 7	PIN 8
V-1	25L6	N.C.	18 ~	*150 ~	*2700 ~	Vary Vol. Control 153K to 1.1 Meg.	36 ~	0 ~	150 ~

* Taken with respect to positive terminal of Selenium Rectifier.

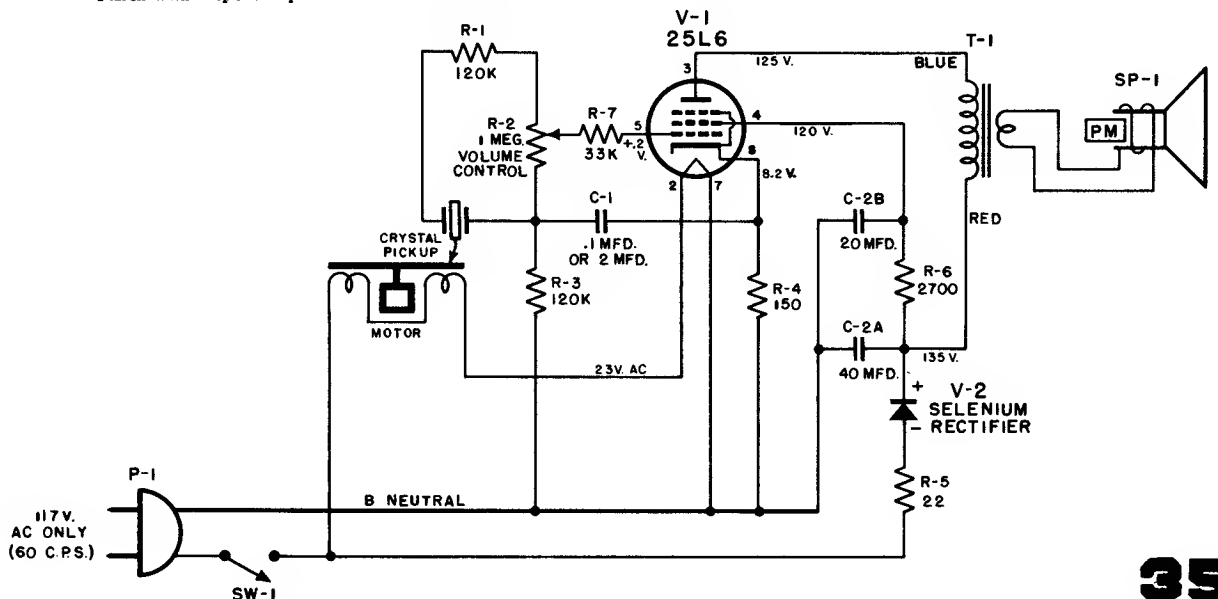

Emerson Radio

MODEL - 788B

CHASSIS - 120201B

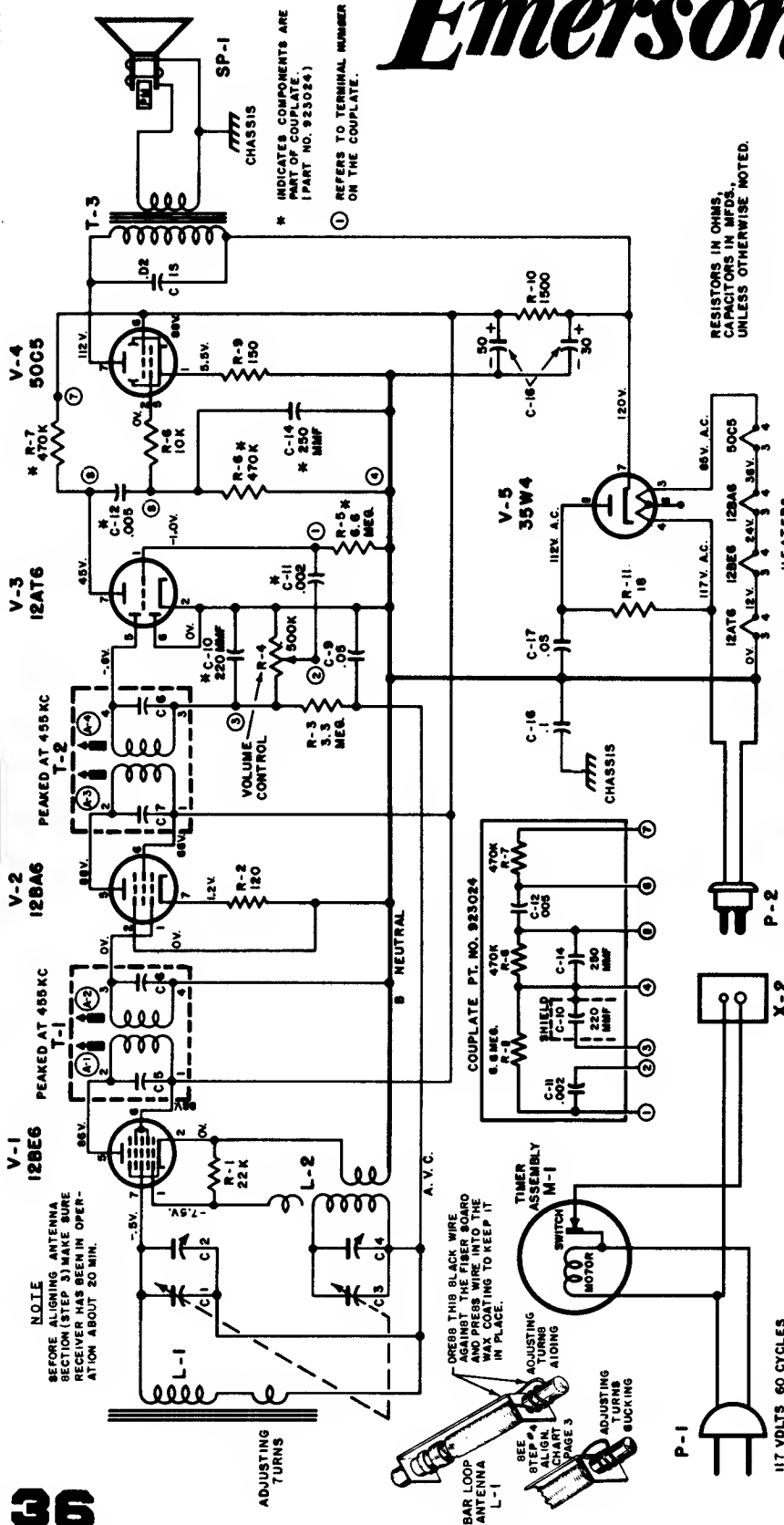

ALIGNMENT INSTRUCTIONS

STEP	SIGNAL GENERATOR COUPLING	SIGNAL GENERATOR FREQUENCY	RADIO DIAL SETTING	OUTPUT METER	ADJUST	REMARKS
1	High side through .005 MFD to grid (pin 7) of V-1 (12BE6). Low side to B neutral. See alignment Note No. 1.	455 KC	Variable condenser fully open.	Across voice coil.	T-2, T-1 (A-3, A-4 A-1, A-2)	Adjust for maximum output.
2	Form loop of several turns and radiate signal into receiver	1630 KC	Variable condenser fully open.	Across voice coil.	Trimmer C-4 (OSC.)	Adjust for maximum output.
3	Form loop of several turns and radiate signal into receiver	1400 KC	Tune for Max. output.	Across voice coil.	Trimmer C-2 (ANT.)	Adjust for maximum output.

MANUAL OF 1954 MOST-OFTEN-NEEDED RADIO DIAGRAMS

Emerson

MODEL - 790B

CHASSIS - 120147-B

RESISTANCE READINGS FOR CHASSIS 120147-B

SYMBOL	TUBE	PIN 1	PIN 2	PIN 3	PIN 4	PIN 5	PIN 6	PIN 7
V-1	1R5	0 ~	• 1.5K	• 16.5K	100K	0 ~	3.2 MEG	14 ~
V-2	1U4	26 ~	• 1.5K	Infinite	Infinite	26 ~	3.3 MEG	38 ~
V-3	1U5	14 ~	• 1.0 MEG	• 4.7 MEG	1.0 MEG	NC	10 MEG	26 ~
V-4	3V4	38 ~	• 1.5K	• 1.5K	300 ~	46 ~	3.6 MEG	56 ~
V-5	117Z3	NC	2.24K	490 ~	0 ~	490 ~	2200 ~	22K

*Resistance measured to Pin 6 of Rectifier 117Z3 (B+)

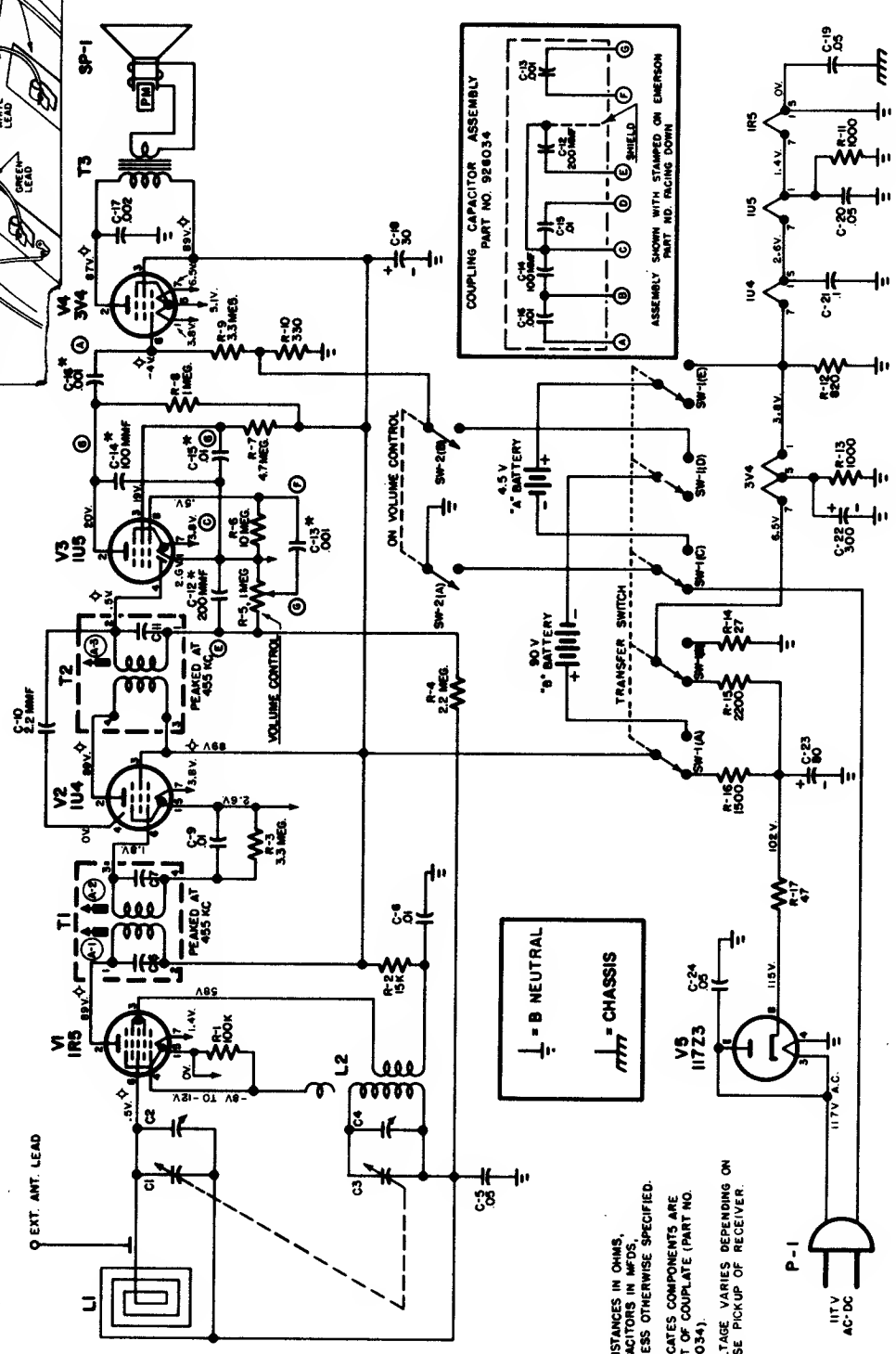
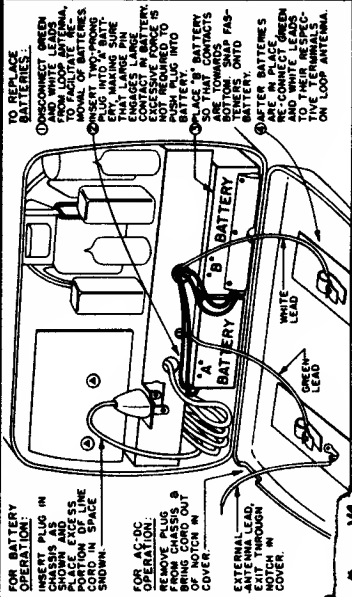

NOTE: RESISTANCES IN OHMS, CAPACITORS IN MFDS, UNLESS OTHERWISE SPECIFIED.
 * INDICATES COMPONENTS ARE PART OF COUPLER (PART NO. 928034).
 ⚡ VOLTAGE VARIES DEPENDING ON NOISE PICKUP OF RECEIVER.

MANUAL OF 1954 MOST-OFTEN-NEEDED RADIO DIAGRAMS

Emerson Radio

MODEL - 805B

CHASSIS - 120202-D

STEP	DUMMY ANTENNA	SIGNAL GENERATOR COUPLING	SIGNAL GENERATOR FREQUENCY	RADIO DIAL SETTING	OUTPUT METER	ADJUST	REMARKS
1	.005 mfd.	High side to grid (pin 7) of V1 (12BE6). Low side to B-neutral	455 KC	Variable condenser fully open.	Across voice coil.	T2, T1 (A3, A4, A1, A2)	Adjust for maximum output.
2		Form loop of several turns and radiate signal into receiver	1620 KC	"	Across voice coil.	Trimmer C-4 (Osc.)	Adjust for maximum output.
3		"	1400 KC	Tune for maximum output.	Across voice coil.	Trimmer C-2 (Ant.)	Adjust for maximum output.

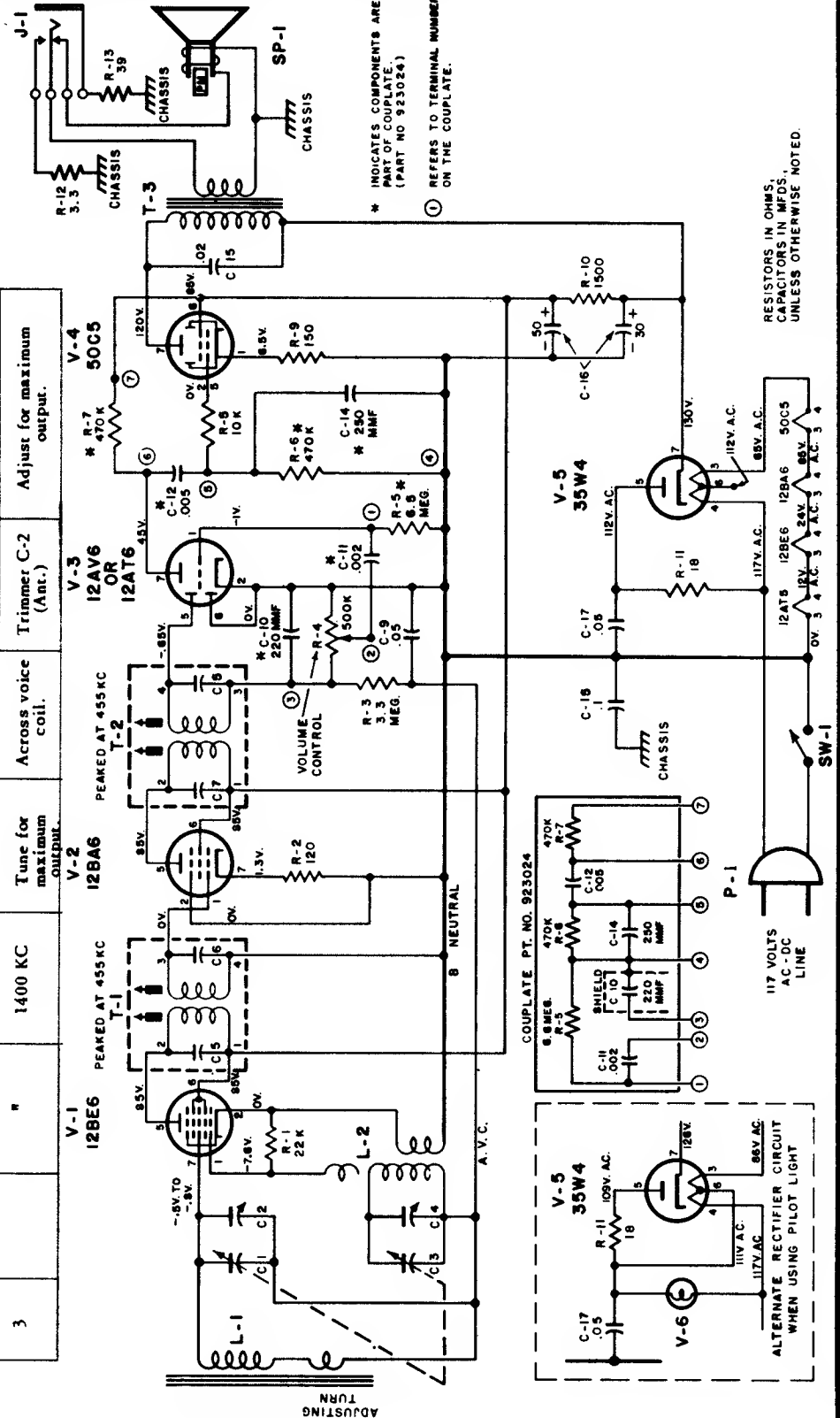

* INDICATES COMPONENTS ARE PART OF COUPLATE. (PART NO 923024)
 ① REFERS TO TERMINAL NUMBER ON THE COUPLATE.

RESISTORS IN OHMS, CAPACITORS IN MFDS., UNLESS OTHERWISE NOTED.

MANUAL OF 1954 MOST-OFTEN-NEEDED RADIO DIAGRAMS

Gamble-Shogmo, Inc.

CORONADO RADIO MODEL 35RA37-43-8355

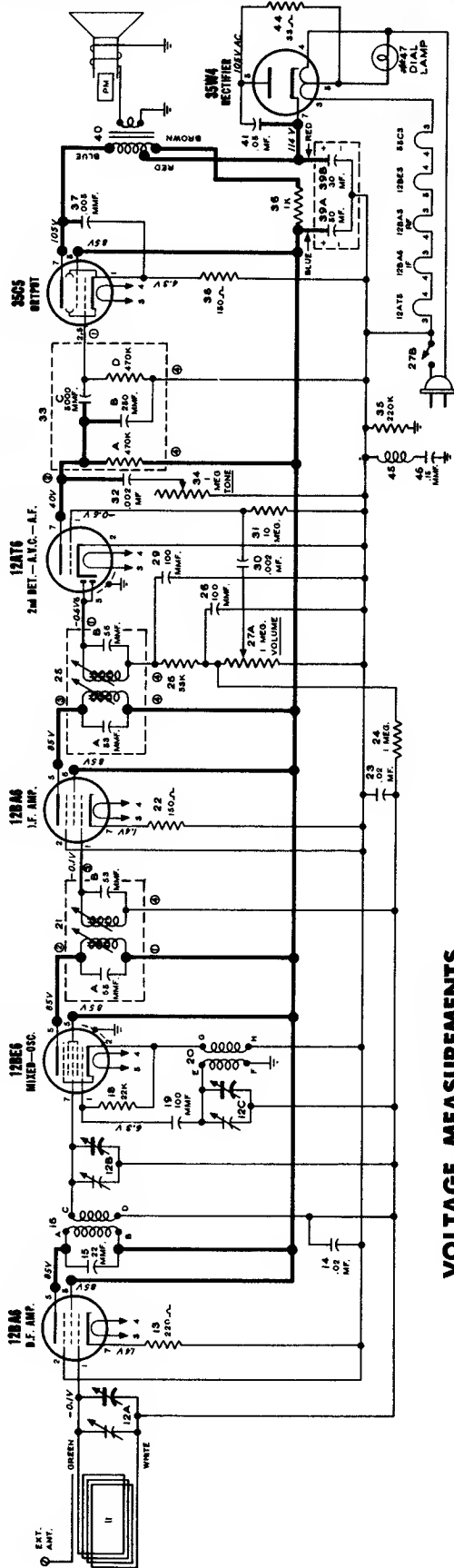

I. F.

455 K. C.

Lettered terminals in illustration correspond to similarly lettered terminals on the circuit diagram.

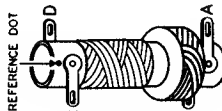

R.F. COIL
521396

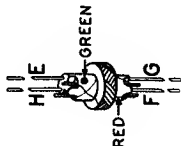

OSCILLATOR
COIL
506094

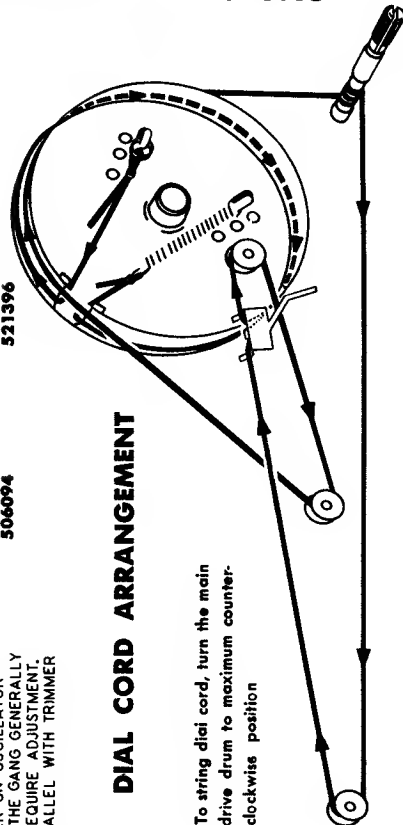

DIAL CORD ARRANGEMENT

To string dial cord, turn the main drive drum to maximum counter-clockwise position

VOLTAGE MEASUREMENTS

All voltages measured to B—using a 20,000 ohm per volt meter with the receiver connected to a 117 volt 60 cycle power supply.
Loop terminals shorted together.

No voltage reading at a tube element indicates zero voltage or voltage which cannot be accurately measured with a 20,000 ohm per volt meter.

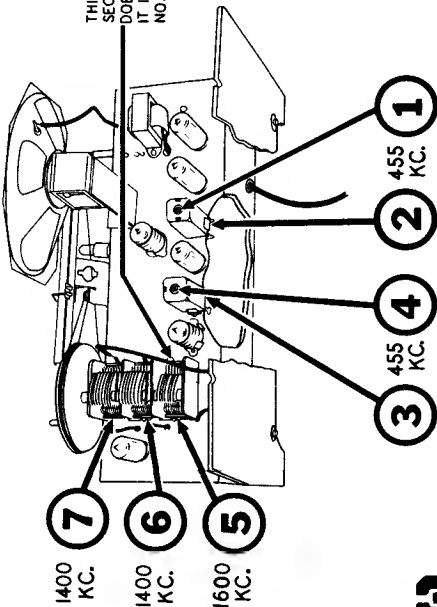

TRIMMER LOCATION CHART

MANUAL OF 1954 MOST-OFTEN-NEEDED RADIO DIAGRAMS

GAMBLE - SKOGMO, INC.

CORONADO RADIO MODEL 35RA40-43-8247A

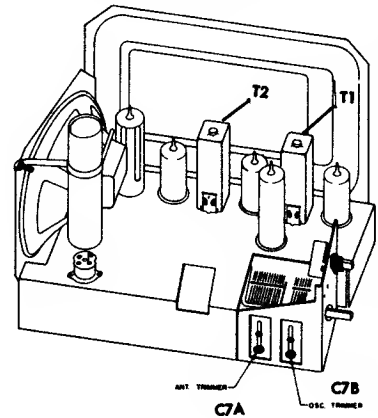
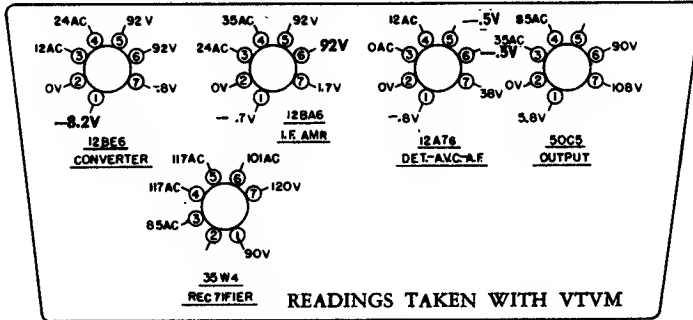

Frequency	Dummy Antenna	Connection to Radio	Position of Variable	Adjust for Maximum Output
455 KC	05	Pin 7 — 12BE6 Converter Grid	Rotor Open (Plates Out of Mesh)	T2 — Pri. and Sec.
455 KC	05	Pin 7 — 12BE6 Converter Grid	Rotor Open (Plates Out of Mesh)	T1 — Pri. and Sec.
1650 KC	05	Pin 7 — 12BE6 Converter Grid	Rotor Open (Plates Out of Mesh)	C7B — Osc. Trimmer
1500 KC		Several Turns Around Loop Ant.	1500 KC	C7A — Ant. Trimmer

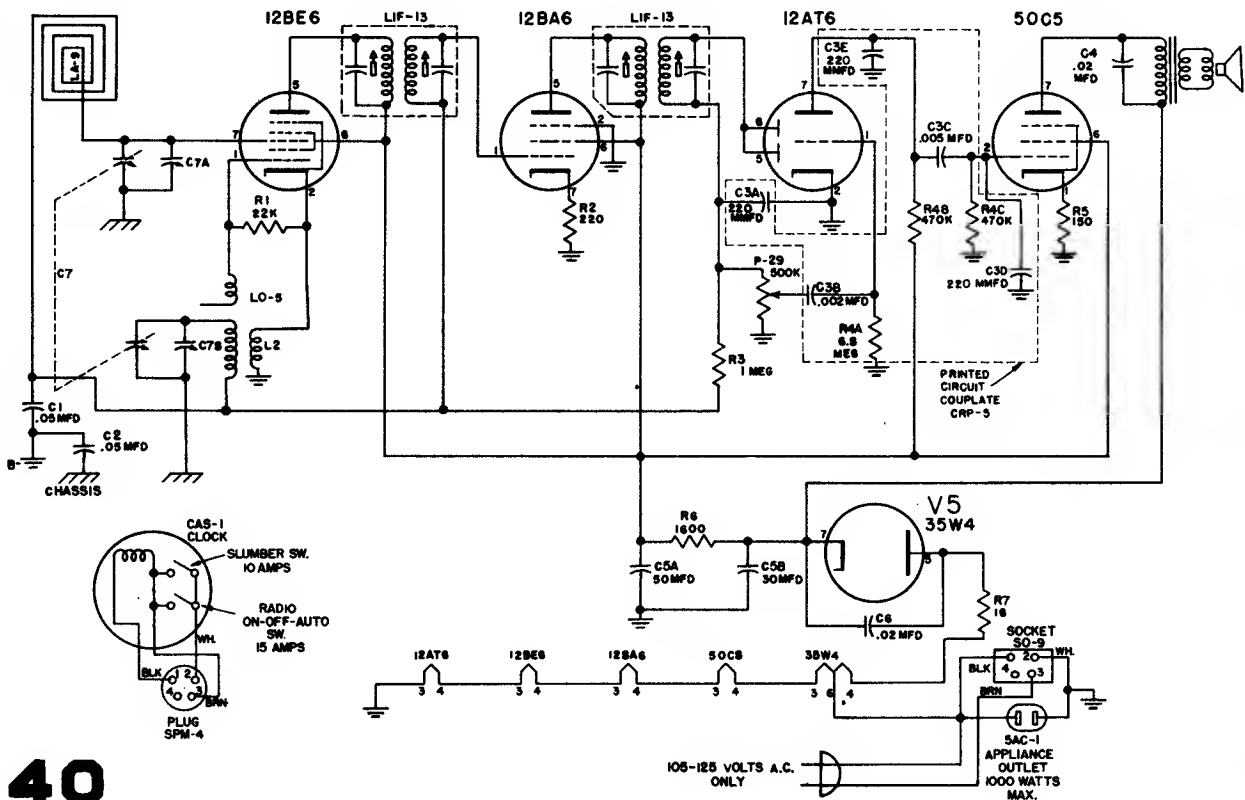

MANUAL OF 1954 MOST-OFTEN-NEEDED RADIO DIAGRAMS

GAMBLE - SKOGMO, INC.

CORONADO RADIO

MODEL RA 42-9850A

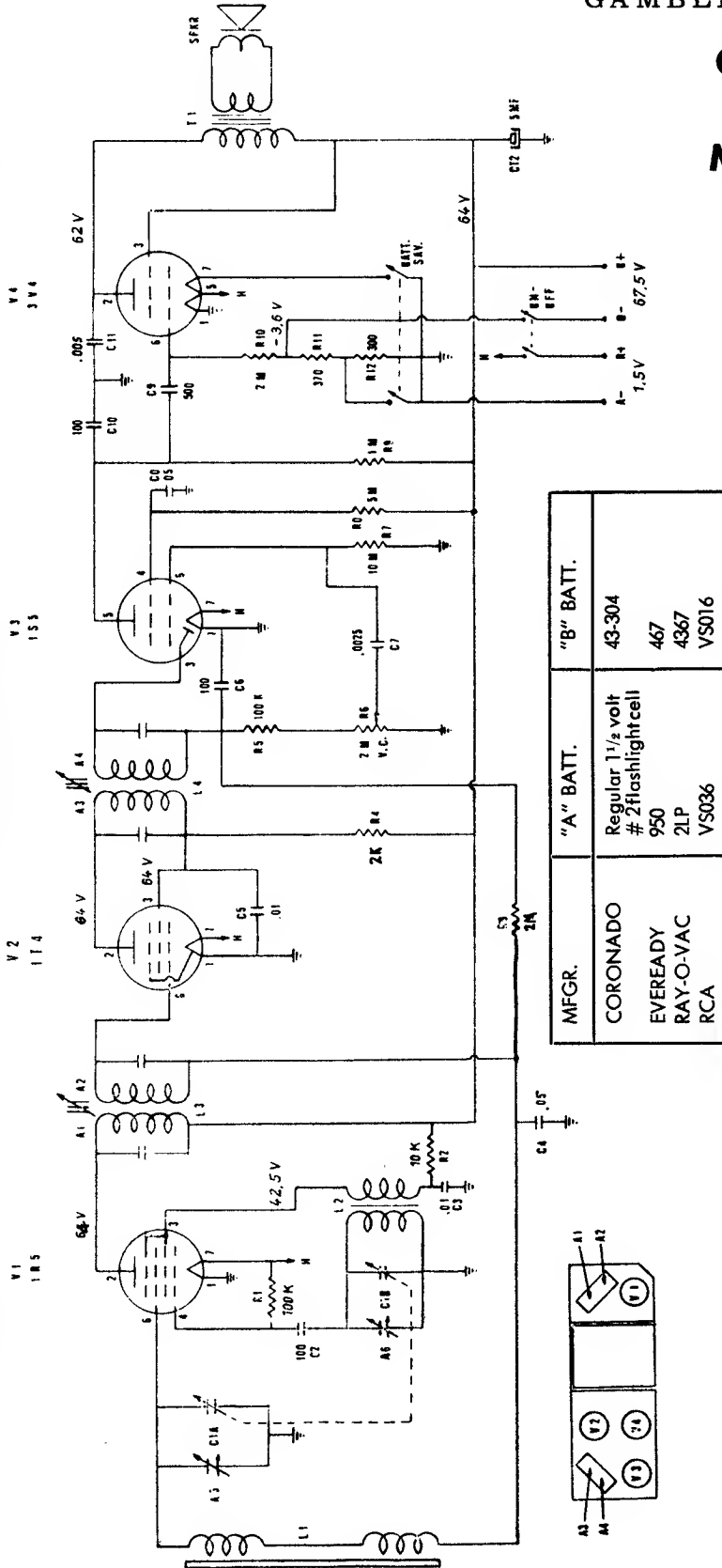

Volume control should be at maximum position. Output of signal generator should be no higher than necessary to obtain an output reading. Use an insulated screwdriver for adjusting.

DUMMY ANTENNA	SIGNAL GENERATOR COUPLING	SIGNAL GENERATOR FREQUENCY	RADIO DIAL SETTING	OUTPUT METER	ADJUST	REMARKS
1. .1 mfd	High side to pin 6 (grid) of 1R5 (V1) Low side to chassis.	460 Kc. 400 c. Modul.	1600 Kc.	Across voice coil.	A1, A2, A3, A4	Adjust for maximum output. Repeat step 1. for greatest accuracy.
2.	Loop	1400 Kc.	tune in 1400 Kc. signal.	"	A5	Adjust for maximum output.
3.	Loop	1620 Kc.	tune in 1620 Kc. signal.	"	A6	Adjust for maximum output.

MANUAL OF 1954 MOST-OFTEN-NEEDED RADIO DIAGRAMS



Models 450, 451, and 452
Models 424 and 425 are similar.

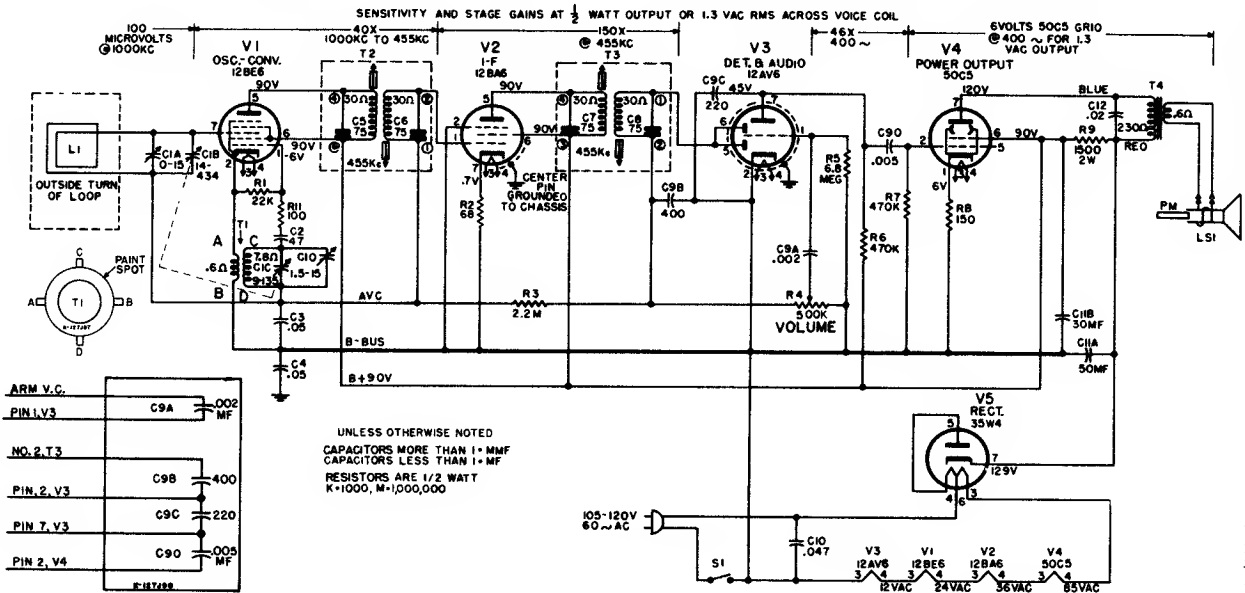

UNLESS OTHERWISE NOTED
CAPACITORS MORE THAN 1-MF
CAPACITORS LESS THAN 1-MF
RESISTORS ARE 1/2 WATT
K=1000, M=1,000,000

ARM V.C.	C9A	.002 MF
PIN 1, V3	C9B	400
NO. 2, T3	C9C	220
PIN 2, V3	C9D	.005 MF
PIN 2, V4	C9E	.005 MF

ALIGNMENT CHART

STEP	CONNECT TEST OSCILLATOR TO	TEST OSC. SETTING	RADIO DIAL SETTING	ADJUST FOR MAXIMUM
I-F ALIGNMENT				
1	V2, 12BA6 grid (Pin 1) in series with .05 mfd.	455 KC		Cores of second I-F trans. T3
2	V1, 12BE6 grid (Pin 7) in series with .05 mfd.			Cores of first I-F trans. T2
3				Recheck adjustment of T3 and T2
R-F ALIGNMENT				
4	Inductively coupled to radio loop	1620 KC	Tuning gang open	C1D, oscillator trimmer
5		1500 KC	For maximum	C1A, Antenna trimmer*

*Rock tuning gang for maximum, while adjusting C1A.

Chassis Removal

The tuning knob is captivated to the cabinet by means of a spring clip and therefore cannot be pulled away from the cabinet in the usual manner. After loosening the chassis, simply pull it towards the rear to disengage the tuning gang shaft.

CATNO.	SYMBOL	DESCRIPTION
RCE-160	C11A, B	50-50 mf., 150 V., cardboard tubular electrolytic
RCN-050	C12	.02mf., 600 V., paper molded
RCN-053	C10	.047mf., paper molded
RCT-066	C1A, B, C, D	Tuning, two gang
RCW-3048	C9A, B, C, D	.002mf., .400mf., .220mf., .005mf., ceramic couplet...
RCW-3075	C2	.47mf., ±20%, N2200, ceramic
UCC-045	C3, 4	.05mf., 600 V., paper

RESISTORS

RRC-205	R4, S1	500K ohms, volume control and switch
URD-021	R1	68 ohms, ±10%, 1/2 w. carbon
URD-025	R10	100 ohms, ±10%, 1/2 w. carbon
URD-029	R8	150 ohms, ±10%, 1/2 w. carbon
URD-081	R1	22K ohms, ±10%, 1/2 w. carbon
URD-113	R6, 7	470K ohms, ±10%, 1/2 w. carbon
URD-129	R3	2.2 megohms, ±10%, 1/2 w. carbon
URD-141	R5	6.8 megohms, 1/2 w. carbon
URF-053	R9	1500 ohms, ±10%, 2 w. carbon

COILS AND TRANSFORMERS

RLC-122	T1	COIL - Oscillator coil
RTL-143	T2	TRANSFORMER - 1st i-f.
RTL-163	T3	TRANSFORMER - 2nd i-f.
RTO-128	T4	TRANSFORMER - Audio output

MISCELLANEOUS ELECTRICAL

RII-081	WAFER	-Part of i-f trans. receptacle
RII-082	WAFER	-Part of tube receptacle
RJC-004	CONNECTOR	-Loudspeaker connector, fem.
RJC-027	CONNECTOR	-Tube pin connector, part of tube receptacle
RJC-028	CONNECTOR	-Oscillator coil receptacle
RJC-029	CONNECTOR	-Wire push-on type terminal for i-f connecting lead
RJC-030	CONNECTOR	-I-F wafer
RJC-031	CONNECTOR	-I-F wafer
RWL-025	CORD	-Power cord and plug, brown, for Model 452
RWL-026	CORD	-Power cord and plug, ivory, for Models 450, 451
S403D7	LOUDSPEAKER	-4 inch PM

MISCELLANEOUS MECHANICAL

*RHC-024	CLIP	-7/8 in. electrolytic mtg. clip
RHC-061	CLIP	-Holds textolite sub-chassis
RHC-081	CLIP	-Tuning knob retaining clip
RHE-014	EYELET	-Tube receptacle mtg.
RHE-016	EYELET	-I-F receptacle wafer mtg.
*RHG-018	GROMMET	-Rubber grommet for tuning capacitor shock mounting
*RHI-017	STRAIN RELIEF	-Two piece strain relief for power cord entrance in chassis
*RHJ-005	SPACER	-In grommet for shock mtg. tuning capacitor
*RHS-109	SHIELD	-Insulating spacer, black textolite in chassis tube holes
RHS-110	SHIELD	-Tube shield for 12AV6 tube

MANUAL OF 1954 MOST-OFTEN-NEEDED RADIO DIAGRAMS

GENERAL ELECTRIC

MODELS 431A, 432A, 431B, 432B, 433B AND 431BH

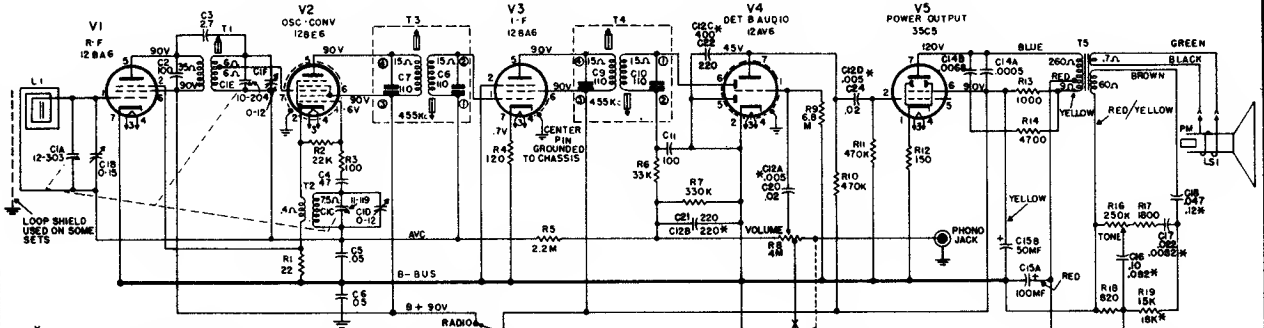

USED ON MODELS 431, 432, 431A, 432A

The 431 and 432 are identical to the 431A and 431B respectively, except as noted in the schematic in regard to S1 and S2. A B+ switch was added to the volume control and the former

The 431B, 432B and 433B chassis are identical. These models also employ the same arrangement of combination Radio-Phono volume control and B+ switch, and Tone control with power On-Off switch, as is used on the Models 431A and 432A. Tone control circuit components, however, were changed as shown in the schematic diagram for the 431B, 432B and 433B receivers. In addition, the ceramic couplate, C12A, B, C, D, used on the other receivers, was replaced by separate capacitors.

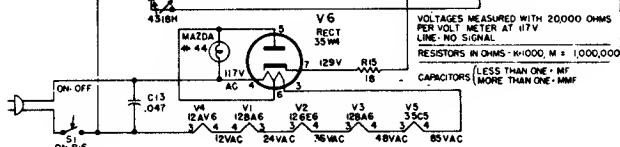

VOLTAGES MEASURED WITH 20000 OHMS PER VOLT METER AT 117V LINE, NO SIGNAL.
RESISTORS IN OHMS - K=1000, M=1,000,000
LESS THAN ONE - MF
CAPACITORS (MORE THAN ONE - MMF)

GENERAL ELECTRIC

MODEL 442, 443 and 444

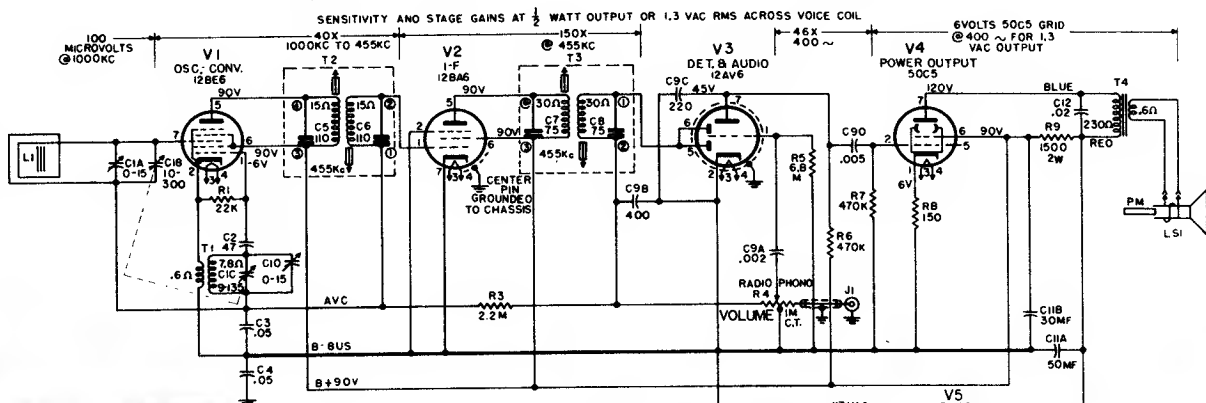
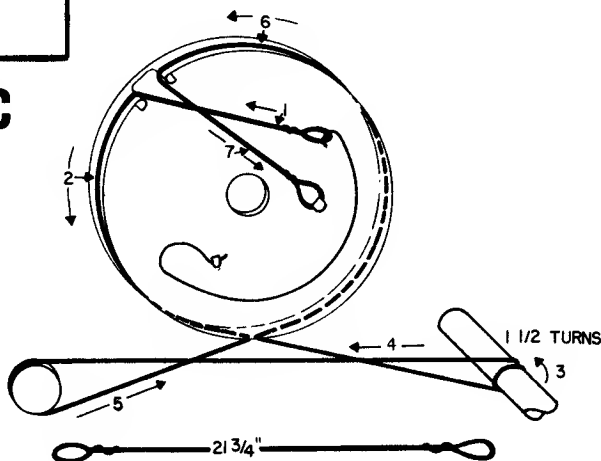
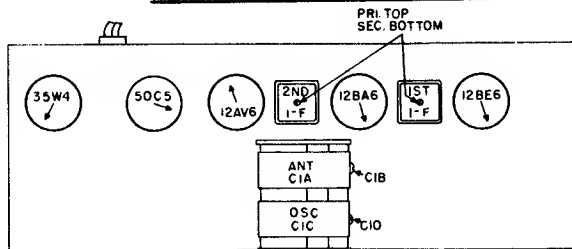

T. ARM OF R4	
TO SOCKET OF 12AV6, PIN 1	C8A .002 MF
TO NOT LINE OF R4	
TO SOCKET OF 12AV6, PIN 3	C9B .002 MF
TO SOCKET OF 12AV6, PIN 7	C9C .002 MF
TO SOCKET OF 35C5, PIN 8	C9D .005 MF

UNLESS OTHERWISE NOTED
CAPACITORS MORE THAN 1 = MMF.
CAPACITORS LESS THAN 1 = MF.
RESISTORS ARE 1/2 WATT. K=1000, M=1,000,000
SOCKET CONNECTIONS: PIN # ON EACH SOCKET IS A DUMMY PIN USED FOR A SPARE TERMINAL. A SMALL HOLE IN THE TUBE SOCKET BETWEEN PINS 105-120V #1 & #8 IS USED TO KEY THESE PINS. 60 ~ AC LINE ON A 20,000 OHMS PER VOLT METER. ALL D.C. VOLTAGES MEASURED AT 117V. READINGS TAKEN BETWEEN TUBE PIN TERMINALS & B+.

MANUAL OF 1954 MOST-OFTEN-NEEDED RADIO DIAGRAMS

GENERAL ELECTRIC

MODEL 440

(Circuit diagram and other service data on adjacent page at the right.)

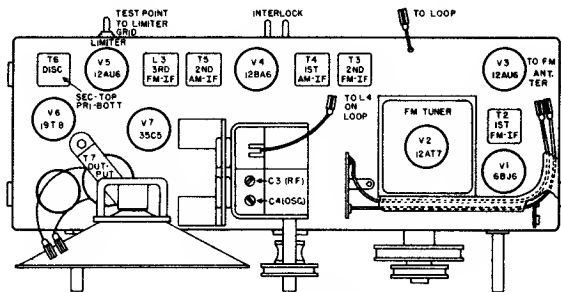

TOP VIEW

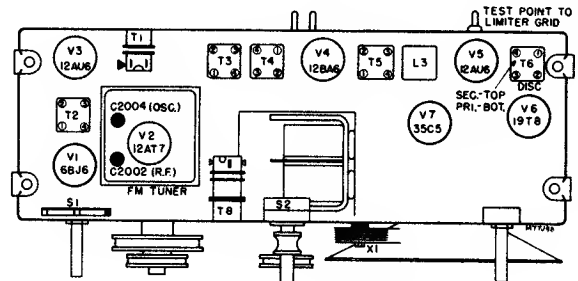

BOTTOM VIEW

ALIGNMENT CHART

	STEP NO.	SIGNAL GENERATOR FREQUENCY	SIGNAL INPUT POINT BETWEEN	TUNING CAPACITOR SETTING	ADJUST	SEE NOTE NO.
AM—I-F	1	455 kc, 30% mod. with 400 cycles	Pin 1 of V4 (12BA6) thru .02 mf. and chassis	Fully closed	Primary and secondary cores of T5 for maximum output meter reading.	1, 2, 4
	2		Pin 1 of V3 (12AU6) thru .02 mf. and chassis		Primary and secondary cores of T4 for maximum output meter reading	
AM—R-F	3	1620 kc, 30% mod. with 400 cycles	Pin 1 of V1 (6BJ6) Inductively coupled to the loop. See Note 3	Fully open (min. cap.)	(C4) oscillator trimmer for maximum output meter reading	1, 2, 4
	4	1500 kc, 30% mod. with 400 cycles		For maximum output meter reading	R-f trimmer (C3) for maximum output meter reading while rocking gang condenser	
	5				Adjust antenna trimmer (C2) on loop for maximum	
FM—I-F	6	10.7 mc unmodulated	Pin 1 of V4 (12BA6) thru 100 mmf. and chassis	Fully closed	Core of L3 for maximum DC reading at test point on rear of chassis	5, 10
	7		Pin 1 of V3 (12AU6) thru 100 mmf. and chassis		Cores of T3 for maximum DC volts at test point on rear of chassis	
	8		Stator of C2001 thru .02 mf. thru hole in bottom of FM tuner cover		Cores of T2 for maximum DC volts at test point on rear of chassis	
FM DIS-CRIMINATOR	9	10.7 mc unmodulated	Pin 1 of V4 (12BA6) thru 100 mmf. and chassis	Fully closed	T6 primary core for maximum DC volts across the volume control R104	6, 7, 10
	10				T6 secondary core for zero DC volts output across volume control R104	
FM—R-F	11	108.5 mc	At FM antenna terminals with built-in FM antenna disconnected	Fully open (min. cap.)	FM oscillator trimmer C2004 for max. DC volts at test point on rear of chassis	5, 8, 9, 10
	12				FM—r-f trimmer C2002 for maximum DC volts at test point on rear of chassis while rocking signal generator frequency	

ALIGNMENT

A-M METER ALIGNMENT NOTES

1. Connect an output meter across the speaker leads to indicate maximum output during AM alignment.
2. Turn the volume control to maximum clockwise position and reduce signal input so that output meter does not indicate more than 1/2 watt output during AM alignment.
3. For alignment of the antenna trimmer C2, it is necessary to inductively couple the signal generator output to the loop antenna by connecting a four-turn, six-inch diameter loop of wire across the generator output terminals and locating the loop about one foot from the radio loop. The position of loop should not be changed during alignment to prevent possible errors in peak readings.
4. Set the band switch in "AM" position.

F-M METER ALIGNMENT NOTES

5. Connect a vacuum tube voltmeter between the test point on the rear of the chassis and chassis to read the DC voltage developed at the limiter grid during FM—i-f and r-f alignment. Dress the VTVM leads away from the r-f end of the chassis to prevent regeneration. Reduce the signal input so that the VTVM reads approximately 1 volt DC.
6. Connect a VTVM across the volume control to read the discriminator output.
7. To align the primary of T6 (discriminator), detune the secondary core slightly until some DC voltage is read across the volume control, then adjust the primary of T6 for maximum.
8. For FM—r-f alignment, the output impedance of the signal generator should be 300 ohms to properly match the input impedance of this receiver.
9. The cover on the FM tuner must be in place during FM—r-f alignment.
10. Set the band switch to the "FM" position.

MANUAL OF 1954 MOST-OFTEN-NEEDED RADIO DIAGRAMS

GENERAL ELECTRIC

MODEL 440

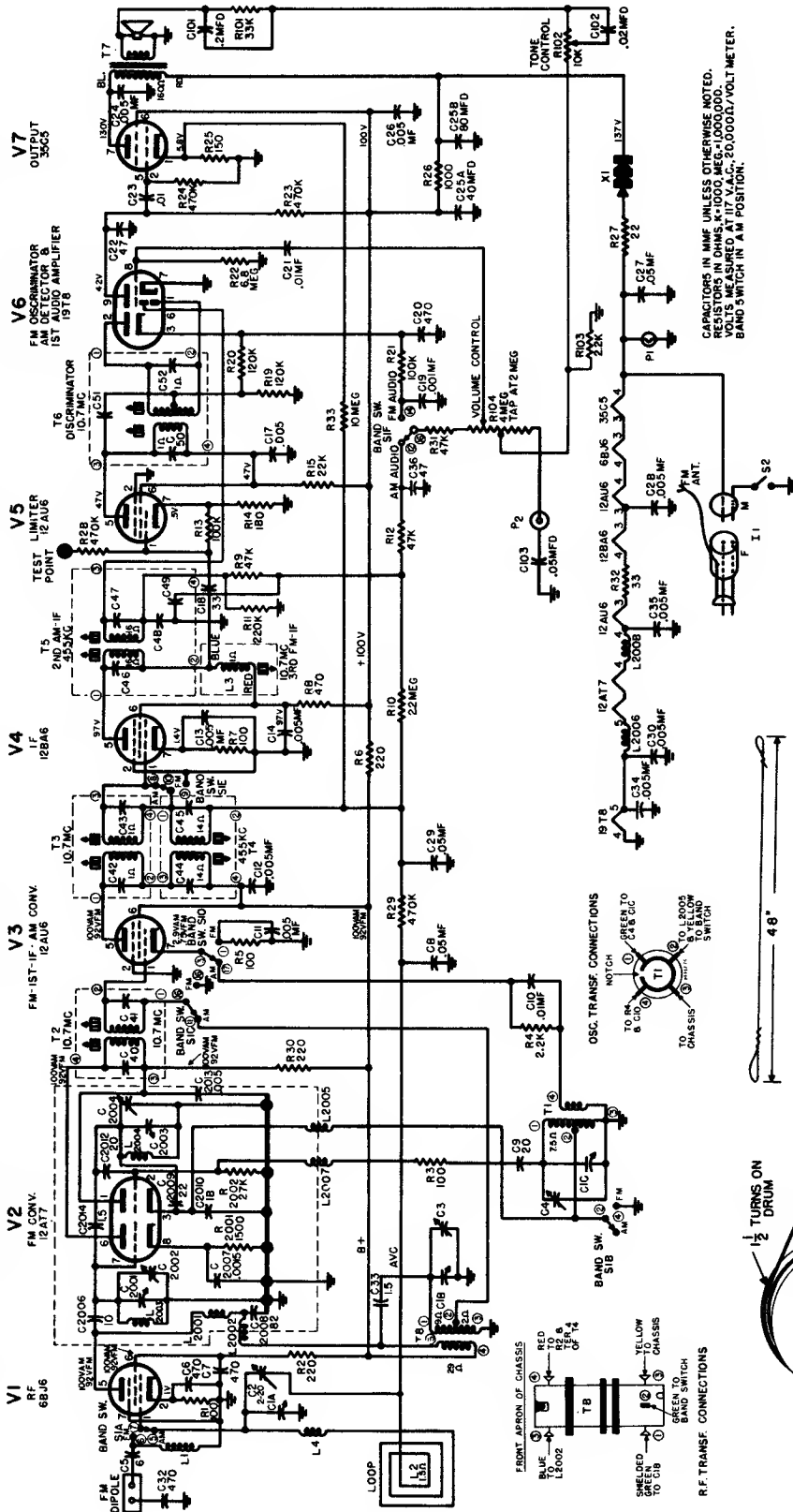

(See adjacent page at the left for complete alignment information)

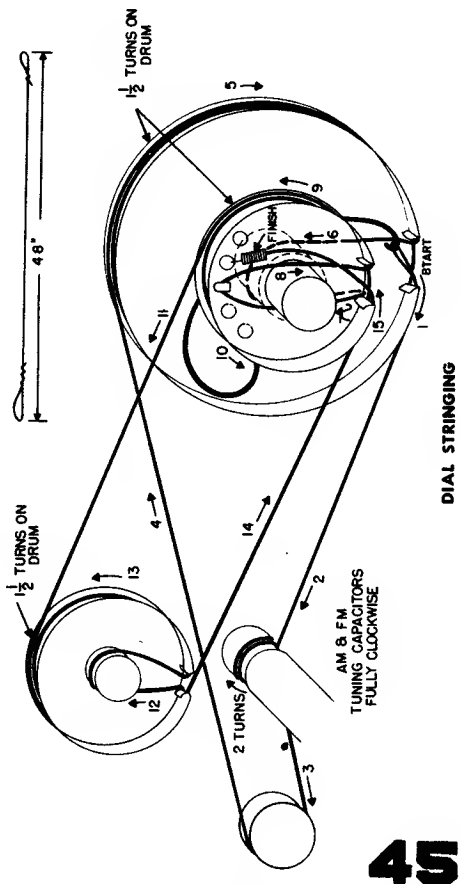
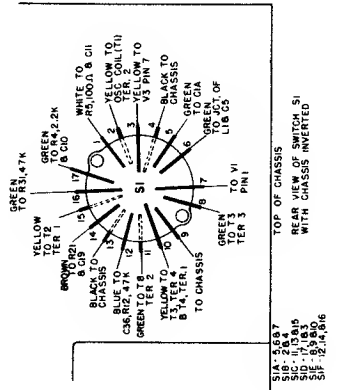

MANUAL OF 1954 MOST-OFTEN-NEEDED RADIO DIAGRAMS

GENERAL ELECTRIC

MODEL 555 AND 556 CLOCK-RADIO RECEIVERS

(For additional information on these models see the next page, adjacent at right.)

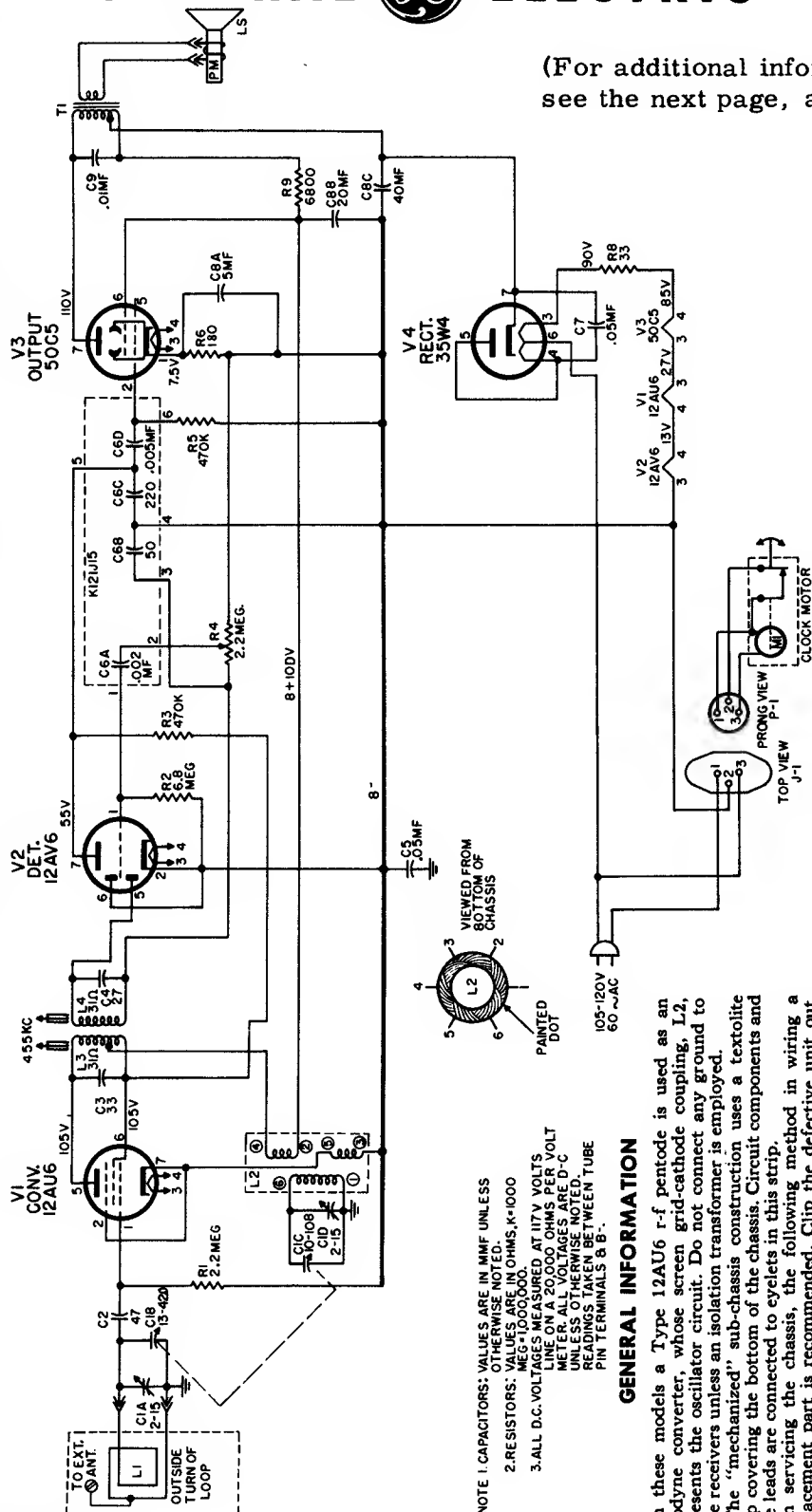

ALIGNMENT CHART

Step	Connect Test Oscillator To	Test Oscillator Setting	Tuning Gang Setting	Adjust for Maximum
I-F ALIGNMENT				
1	12AU6, V1, grid through .05 mf.	455 KC		L4 and L3 i-f coupling
R-F ALIGNMENT				
2	Inductively coupled to radio antenna loop	1620 KC	Tuning Gang fully open	C1D, oscillator trimmer
3		1500 KC	For maximum output	C1A*, antenna trimmer

*Rock radio dial for maximum while adjusting C1A.

NOTE 1. CAPACITORS: VALUES ARE IN MMF UNLESS OTHERWISE NOTED.
2. RESISTORS: VALUES ARE IN OHMS, K=1000
3. ALL D.C. VOLTAGES MEASURED AT 117V VOLTS LINE ON A 20,000 OHMS PER VOLT METER. ALL VOLTAGES ARE D-C UNLESS OTHERWISE NOTED.
 *RESISTOR VALUE BETWEEN TUBE PIN TERMINALS 8 & 9.

GENERAL INFORMATION

In these models a Type 12AU6 r-f pentode is used as an autodyne converter, whose screen grid-cathode coupling, L2, represents the oscillator circuit. Do not connect any ground to these receivers unless an isolation transformer is employed. The "mechanized" sub-chassis construction uses a textolite strip covering the bottom of the chassis. Circuit components and wire leads are connected to eyelets in this strip.

In servicing the chassis, the following method in wiring a replacement part is recommended. Clip the defective unit out, leaving enough of its leads attached to the strip to form eye loops. Each lead of the replacement component may then be passed through a corresponding loop, pruned to length, crimped and soldered.

To replace an oscillator coil, i-f coil or broken socket beneath the textolite strip, the strip may be raised at the rear of the chassis. To raise the strip, remove the tubes, three screws and rear apron of chassis, and electrolytic capacitor from its mounting clip. Move strip out slightly to clear. Volume control and remove control from front apron of chassis. Raise the textolite strip upward at rectifier tube to a vertical position to reach components for servicing.

If necessary, the strip may be removed completely by disconnecting the wire connections at tuning capacitor and output transformer.

The oscillator or i-f coils may be removed or replaced by heating all pins at the rear of the textolite strip simultaneously, using a large soldering iron; or, if desired, the old coil may be destroyed and the pins removed separately.

MANUAL OF 1954 MOST-OFTEN-NEEDED RADIO DIAGRAMS

GENERAL ELECTRIC

Models 555 and 556

(Continued from pre-
ceding page, at left.)

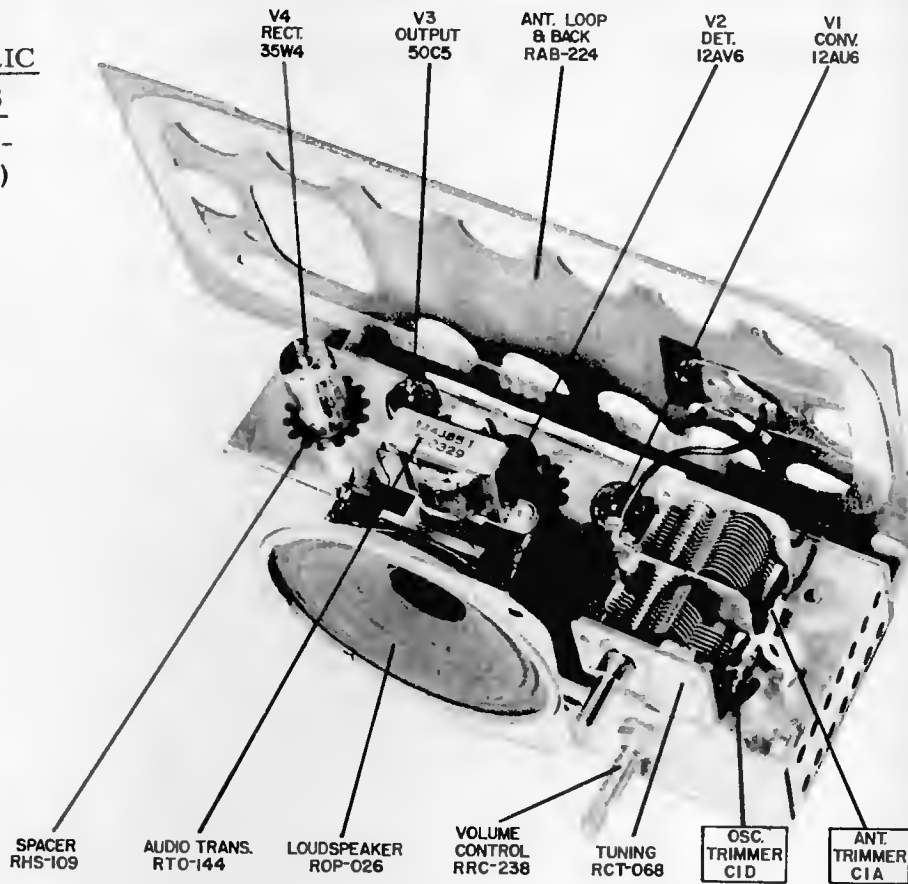
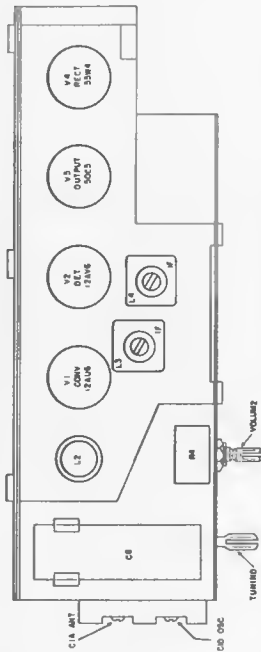

Identification of Components, Top View

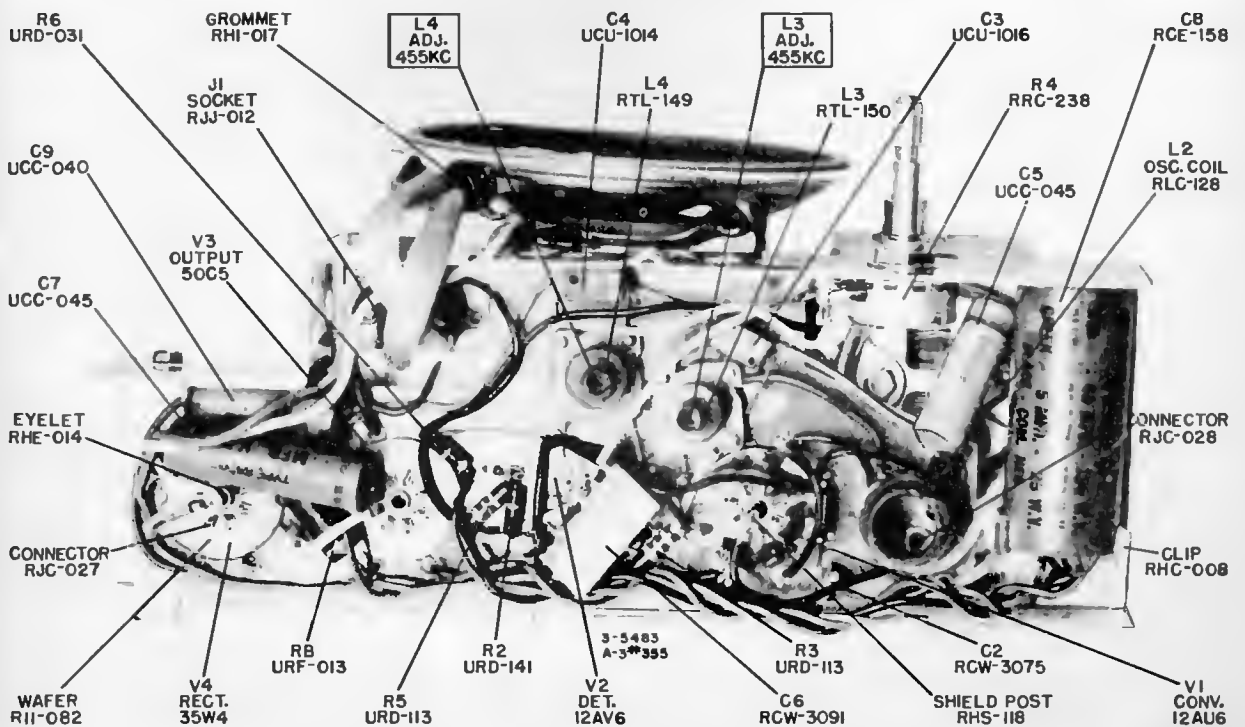

Identification of Components, Bottom View

MANUAL OF 1954 MOST-OFTEN-NEEDED RADIO DIAGRAMS



MODEL 560 AND 561 CLOCK-RADIO RECEIVERS

Models 557, 558, 559, 564, 565, and 566, use the identical radio circuit to Models 560 and 561.

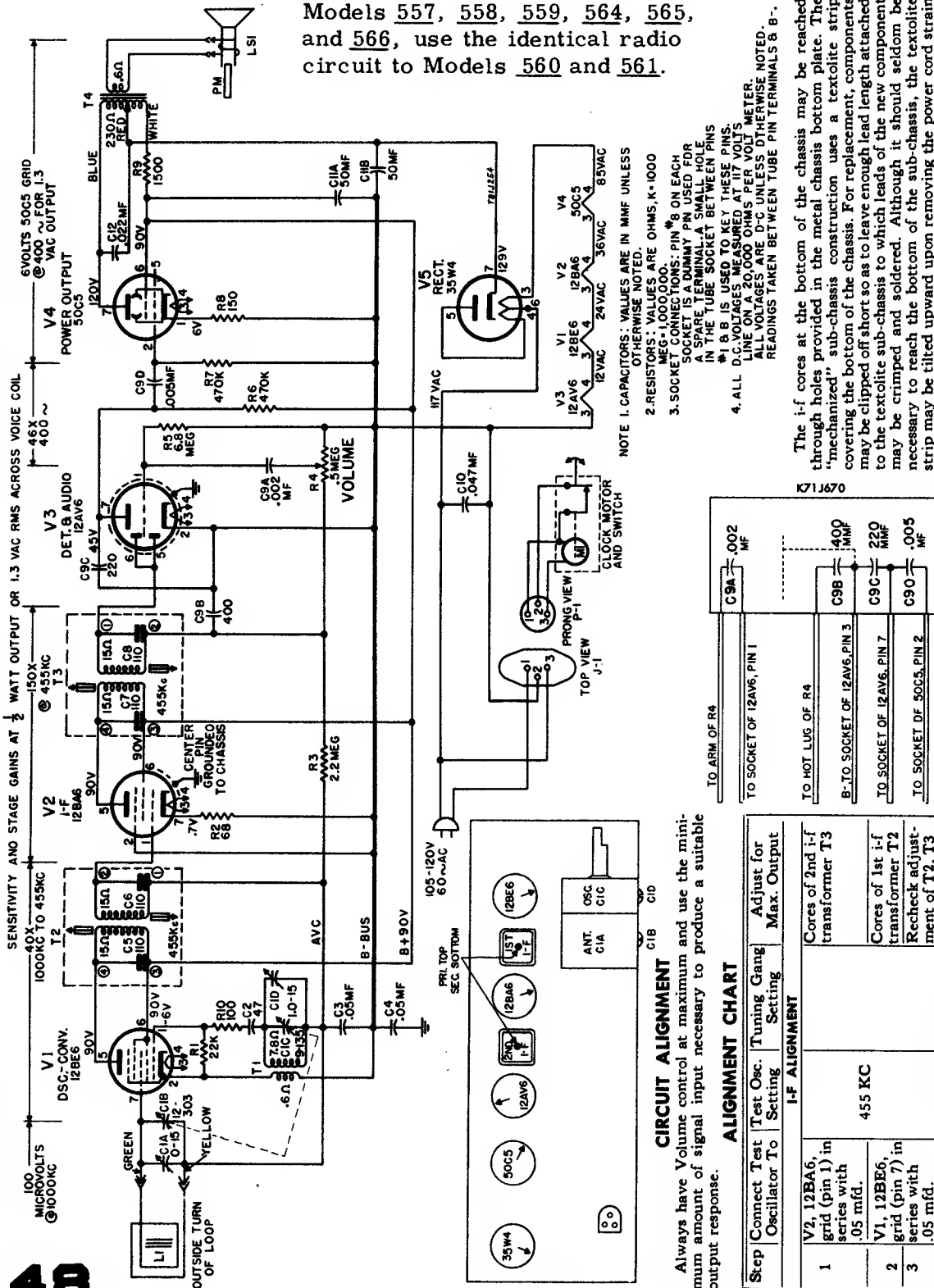

- NOTE 1. CAPACITORS: VALUES ARE IN MMF UNLESS OTHERWISE NOTED.
 2. RESISTORS: VALUES ARE OHMS, K=1000 UNLESS OTHERWISE NOTED.
 3. SOCKET CONNECTIONS: PIN #s ON EACH SOCKET IS A DUMMY PIN USED FOR A SPARE TERMINAL A SMALL HOLE IN THE TUBE SOCKET BETWEEN PINS #1 & 8 IS USED TO KEY THESE PINS.
 4. ALL D.C. VOLTAGES MEASURED AT 117 VOLTS LINE ON A 20,000 OHMS PER VOLT METER. ALL VOLTAGES ARE D-C UNLESS OTHERWISE NOTED. READINGS TAKEN BETWEEN TUBE PIN TERMINALS & B.

The i-f cores at the bottom of the chassis may be reached through holes provided in the metal chassis bottom plate. The "mechanized" sub-chassis construction uses a textolite strip covering the bottom of the chassis. For replacement, components may be clipped off short so as to leave enough lead length attached to the textolite sub-chassis to which leads of the new component may be crimped and soldered. Although it should seldom be necessary to reach the bottom of the sub-chassis, the textolite strip may be tilted upward upon removing the power cord strain relief grommet and disconnecting the wire leads from each i-f transformer. To remove or replace an oscillator coil, heat all four connections simultaneously if possible, or alternately heat one pair and then the other as the coil is rocked out or into position. If desired, the old coil may be destroyed and the pins removed separately.

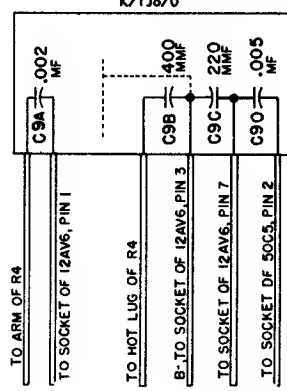

Bullplate Connectors

CIRCUIT ALIGNMENT
 Always have Volume control at maximum and use the minimum amount of signal input necessary to produce a suitable output response.

ALIGNMENT CHART

Step	Connect Test Oscillator To	Test Osc. Setting	Tuning Gang Setting	Adjust for Max. Output
1	V2, 12BA6, grid (pin 1) in series with .05 mfd.	455 KC		Cores of 2nd i-f transformer T3
2	V1, 12BE6, grid (pin 7) in series with .05 mfd.			Cores of 1st i-f transformer T2
3				Recheck adjustment of T2, T3
R-F ALIGNMENT				
4	Inductively coupled to radio loop	1670 KC	Open	C1D
5		1500 KC	For Maximum Output	C1A*

*Rock tuning for maximum, while adjusting C1A.

MANUAL OF 1954 MOST-OFTEN-NEEDED RADIO DIAGRAMS

GENERAL ELECTRIC MODELS 572, 573, 574, 575

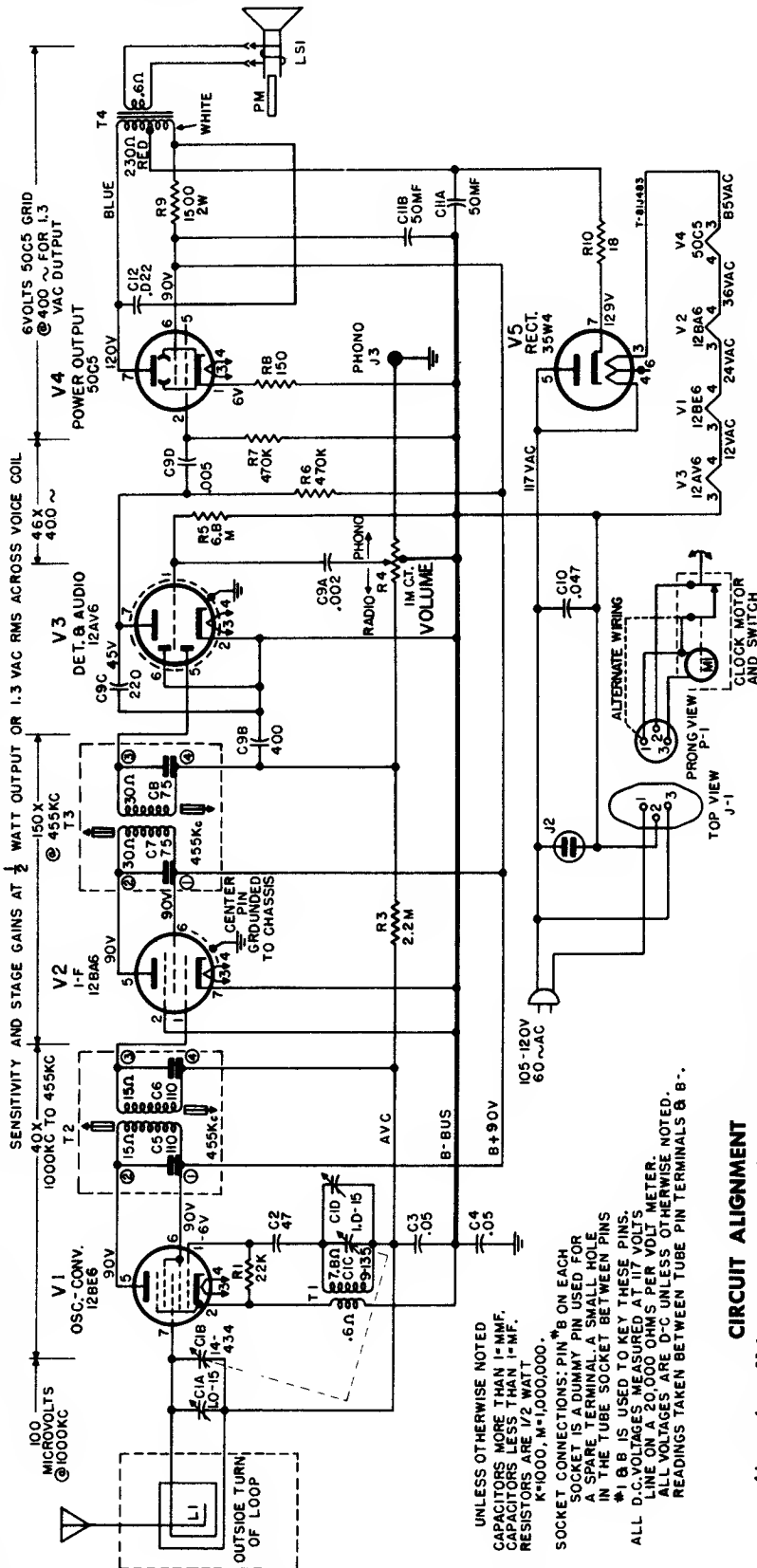

Schematic Diagram, Models 572, 573, 574 and 575

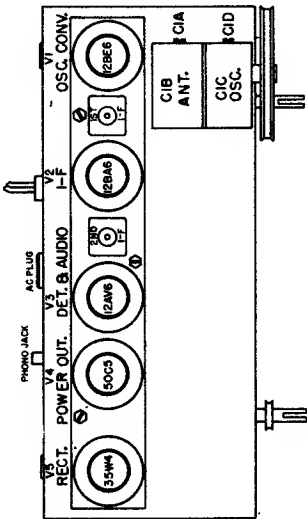
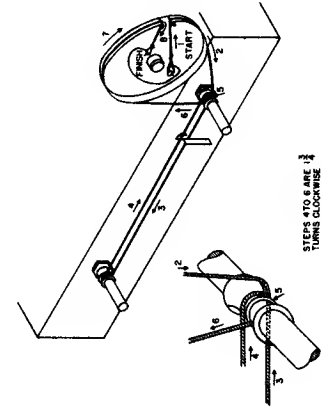

CIRCUIT ALIGNMENT

Always have Volume control at maximum and use the minimum amount of signal input necessary to produce a suitable output response.

ALIGNMENT CHART

Step	Connect Test Oscillator To	Test Osc. Setting	Tuning Gang Setting	Adjust for Max. Output
I-F ALIGNMENT				
1	V2, 12BA6, grid (pin 1) in series with .05 mfd.	455 KC		Adjust for Max. Output
2	V1, 12BE6, grid (pin 7) in series with .05 mfd.			Adjust for Max. Output
R-F ALIGNMENT				
4	Inductively coupled to radio loop	1620 KC	Open	C1D
5		1500 KC	For Maximum Output	C1A*

MANUAL OF 1954 MOST-OFTEN-NEEDED RADIO DIAGRAMS

GENERAL ELECTRIC

MODELS 625 AND 626 PORTABLE RADIO RECEIVERS

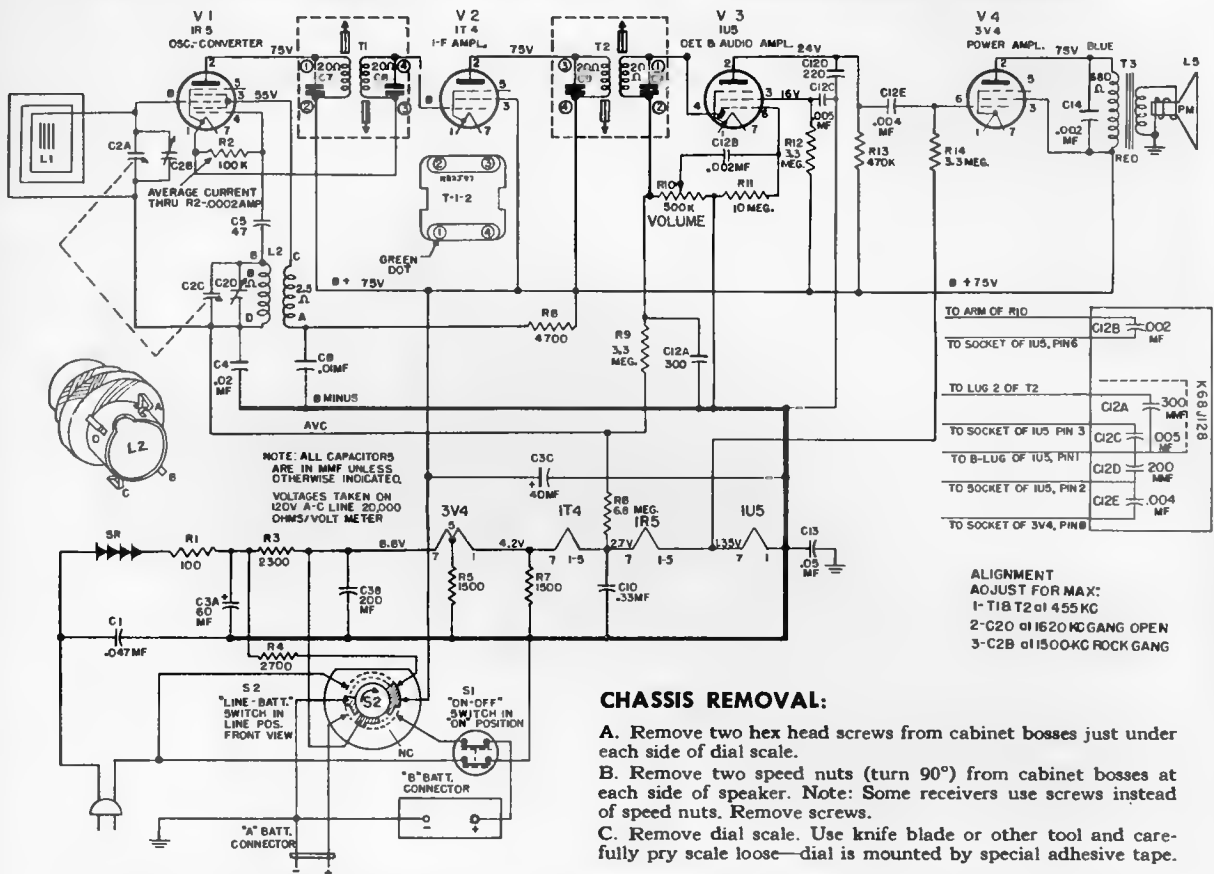

CHASSIS REMOVAL:

- Remove two hex head screws from cabinet bosses just under each side of dial scale.
- Remove two speed nuts (turn 90°) from cabinet bosses at each side of speaker. Note: Some receivers use screws instead of speed nuts. Remove screws.
- Remove dial scale. Use knife blade or other tool and carefully pry scale loose—dial is mounted by special adhesive tape.

BOTTOM SHIELD REMOVAL:

- Remove chassis.
- Remove six trimount studs:
3 across back of chassis
3 across front of chassis (2 under speaker grille).
- Slide bottom down one inch and pull out.

BATTERY INSTALLATION:

The "A" battery is placed in the bottom of cabinet to the left of the loudspeaker. The battery receptacle must face cabinet back. The "B" battery is installed to the right of "A" battery and behind loudspeaker. "B" battery connector buttons must face to the right.

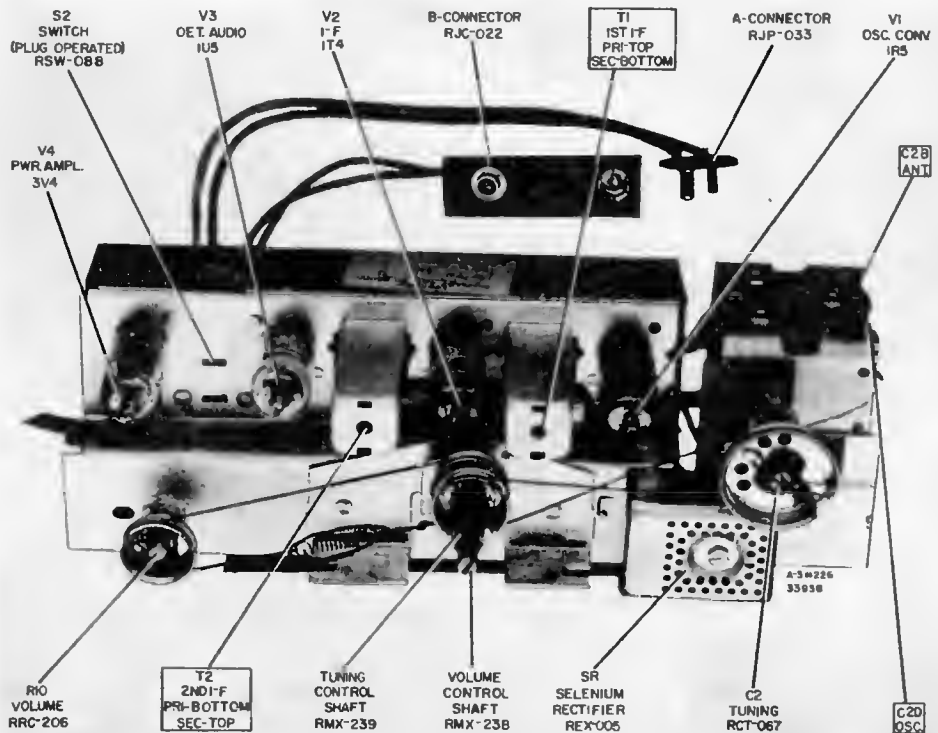

MANUAL OF 1954 MOST-OFTEN-NEEDED RADIO DIAGRAMS

GENERAL ELECTRIC

MODEL 620, 621 AND 622 PORTABLE RADIO RECEIVERS

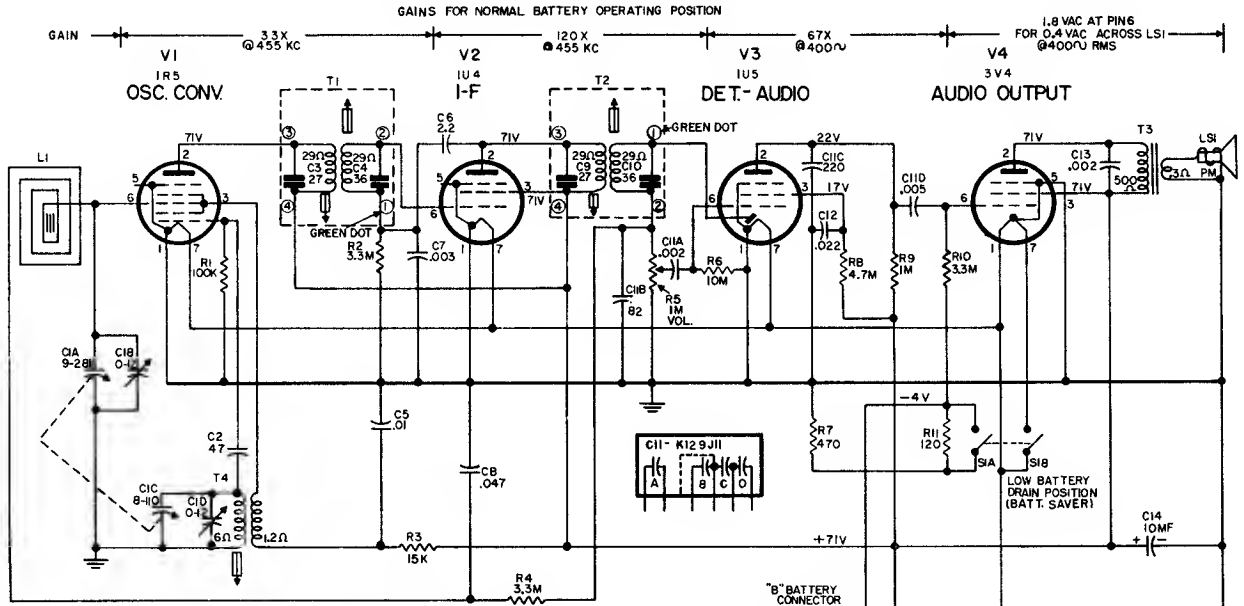

UNLESS OTHERWISE NOTED, CAPACITOR VALUES LESS THAN THE UNIT ARE MF., VALUES MORE THAN 1 ARE MMF.

RESISTANCE VALUES ARE OHMS K=1000 M=1,000,000.

VOLTAGES ARE DC TO CHASSIS GROUND, METER SENSITIVITY 20,000 OHMS/VOLT.

ALIGNMENT
 I-F - PEAK T1 T2 @ 455 KC
 R-F - PEAK C10 @ 1620 KC GANG OPEN.
 2. PEAK C10 @ 1500 KC ROCK GANG.
 3. PEAK IRON CORE T4 @ 600 KC ROCK GANG.
 4. REPEAT AS NECESSARY.

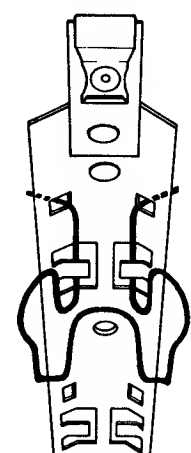
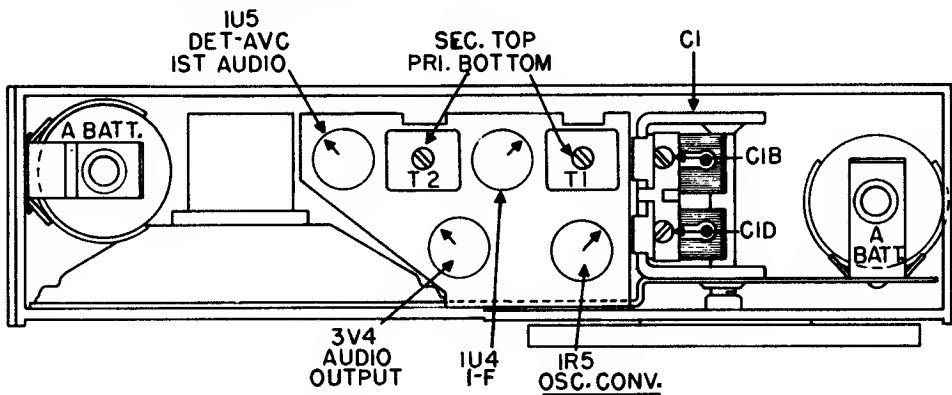

CAPACITORS

*RCC-121	C5	.01 mf., 200 v., paper
*RCC-122	C8	.047 mf., 200 v., paper
*RCC-123	C12	.022 mf., 200 v., paper
RCE-172	C14	10 mf., electrolytic
RCN-082	C11A, B, C, D	Ceramic Bullplate
RCT-075	C1	Tuning
*RCW-3075	C2	47 mmf., ceramic
*RCW-3078	C6	2.2 mmf., $\pm 5\%$, 500 v., ceramic
RCW-3118	C7	.003 mf., $\pm 5\%$, 500 v., ceramic
RCW-3119	C13	.002 mf., $\pm 5\%$, 500 v., ceramic

RESISTORS

RRC-239	R5, S2A, B	VOLUME CONTROL & SWITCH - 1 megohm
*URD-027	R11	120 ohms, carbon
*URD-041	R7	470 ohms, carbon
*URD-061	R2, 4, 10	3.3 K, carbon
*URD-077	R3	15 K, carbon
*URD-097	R1	100 K, carbon
*URD-121	R9	1 megohm, carbon
*URD-137	R8	4.7 megohms, carbon
*URD-145	R6	10 megohms, carbon

MANUAL OF 1954 MOST-OFTEN-NEEDED RADIO DIAGRAMS

GENERAL ELECTRIC

MODEL 640 AND 641 PORTABLE RADIO RECEIVERS

Continued on the next page, adjacent at right.

CHASSIS REMOVAL:

1. Remove the two control knobs.
2. Remove the hex head screw in cabinet bosses at each side of chassis.
3. Remove two hex head screws holding chassis support brackets to bosses in bottom of cabinet.
4. Disconnect audio output leads from loudspeaker and remove complete chassis with brackets.

NOTE:
ALL CAPACITIES ARE IN MFD.
ALL VOLTAGES ARE D-C MEASURED TO B+ USING A 20,000 OHMS PER VOLT METER.
READINGS ARE SIMILAR FOR IIT VOLTS LINE, OR BATTERY INPUT POWER.

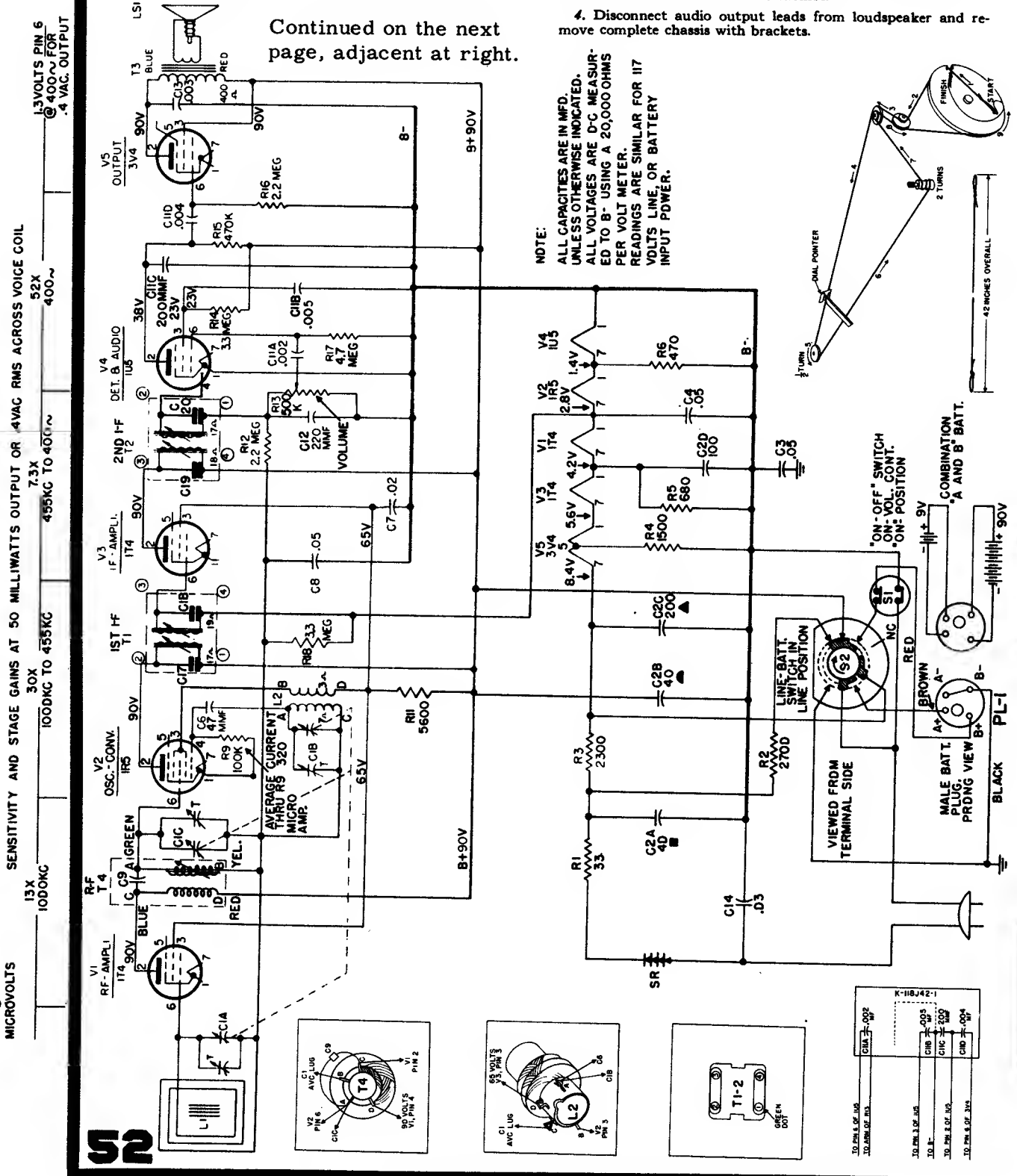
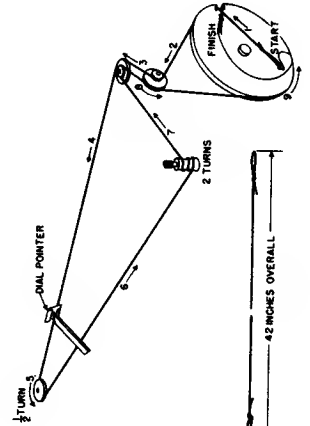

SENSITIVITY AND STAGE GAINS AT 50 MILLIWATTS OUTPUT OR .4VAC RMS ACROSS VOICE COIL

13X	30X	7.3X	52X
100DKC	100DKC TO 455KC	455KC TO 400~	400~

1.3VOLTS PIN 6 @ 400~ FOR .4 VAC OUTPUT

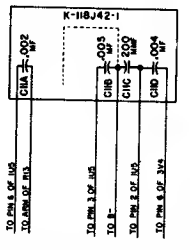
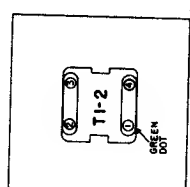
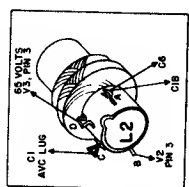
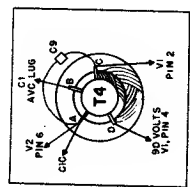

K-118J42-1
C14 .002
C13 .005
C12 .005
C11 .005
C10 .004
C9 .01

TO PIN 4 OF I14
TO PIN 6 OF I14
TO PIN 2 OF I14
TO PIN 2 OF I14
TO PIN 6 OF I14

MANUAL OF 1954 MOST-OFTEN-NEEDED RADIO DIAGRAMS

GENERAL ELECTRIC COMPANY

Models 640 and 641

Continued from preceding page, adjacent at left.

BOTTOM SHIELD REMOVAL:

1. Remove the hex head screw in cabinet bosses at each side of chassis.
2. Remove the three snap fasteners holding shield to back edge of chassis.
3. Remove the hex head screw holding bottom shield to each end of chassis.
4. Withdraw shield to position exposing chassis components.

ALIGNMENT CHART

Always have volume control full on and reduce signal input so A-V-C will not affect output.

Step	Test-oscillator Connected to	Test Osc. Setting	Pointer Setting	Adjust for Maximum Output
1	1T4 (V3) I-F grid (pin 6) in series with .05 mfd. and B- bus.	455 KC	550 KC	Iron cores of 2nd I-F Transformer, T2.
2	1R5 (V2) converter grid (pin 6) in series with .05 mfd. and B- bus.	455 KC	550 KC	Iron cores of 1st I-F Transformer, T1.
3	1T4 (V1) R-F amplifier grid (pin 6) in series with .05 mfd. and B- bus.	1670 KC	Gang condenser (C1A, B, C) fully open	C1B oscillator trimmer.
4		1500 KC	For max. output	C1C R-F trimmer.
5		580 KC	For max. output	Core of T4.
6	Repeat steps 4 and 5 to give maximum output.			
7	Inductively coupled to loop, L1	1500 KC	For max. output	C1A antenna trimmer.

Components and Adjustments, Top View

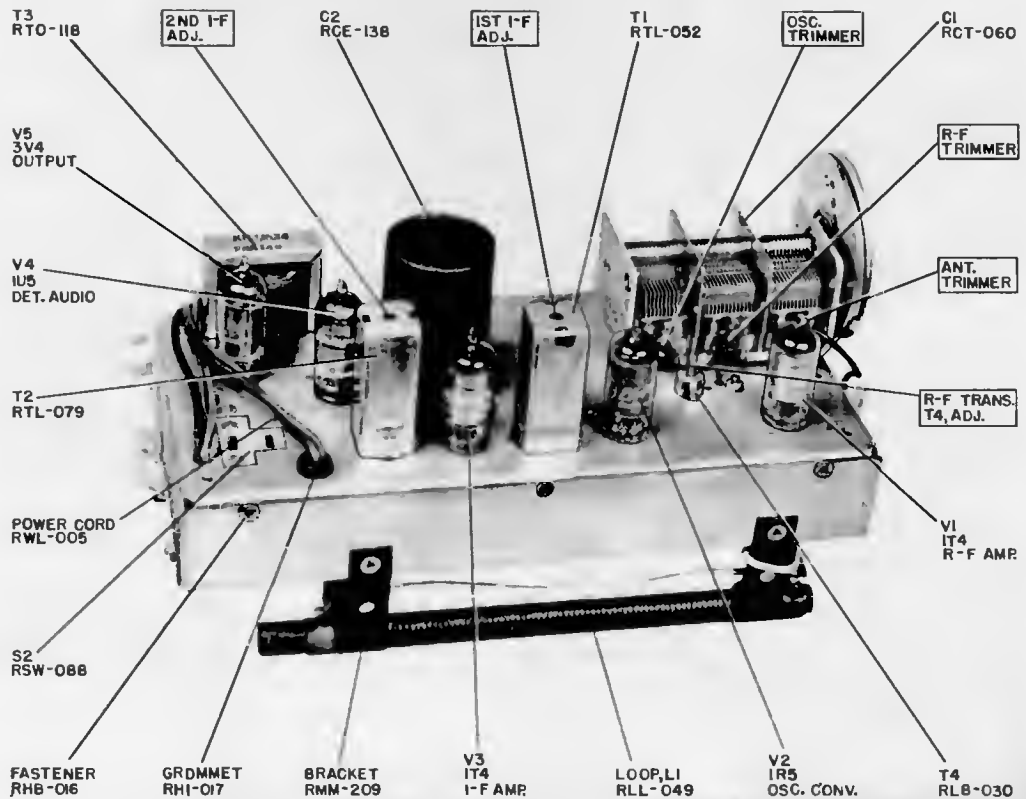

MANUAL OF 1954 MOST-OFTEN-NEEDED RADIO DIAGRAMS

GENERAL ELECTRIC COMPANY

MODEL 630, 631 AND 632 PORTABLE RADIO RECEIVERS

SPECIFICATIONS

CABINETS (Plastic)	Model 630 - Green; Model 631 - Red; Model 632 - Gray
DIMENSIONS	10 5/16 x 8 x 4 inches
ELECTRICAL RATING	105-120 volts A-C (50/60 cycles), or D-C "A" Batteries - 2 Eveready #964 or Burgess #21R, or equivalent "B" Battery - 1 Eveready #467 or Burgess #XX45, or equivalent
OPERATING FREQUENCIES	Tuning range 540 - 1600 KC I-F Amplifier 455 KC
AUDIO POWER OUTPUT	Undistorted 100 milliwatts Maximum 120 milliwatts
LOUDSPEAKER	4-inch PM, 3.2 ohms VC @ 400 cps
TUBE COMPLEMENT	V1 - Oscillator-Converter 1R5 V2 - I-F Amplifier 1U4 V3 - Detector & Audio Amplifier 1U5 V4 - Power Amplifier 3V4

COILS AND TRANSFORMERS

*RLC-101	L2	COIL - Oscillator
RLI-059	L1	ANTENNA ASSEMBLY -Iron core
RTL-156	T1,2	TRANSFORMER -I-F
*RTO-133	T3	TRANSFORMER -Output

CAT.NO.	SYMBOL	DESCRIPTION
CAPACITORS		
*RCC-123	C3	.002 mf., 20%, 200 V., paper
RCC-125	C16	.047 mf., 400 V., paper
*RCE-151	C10A,B,C	60-40-200 mf., electrolytic
*RCN-039	C1,7	2.2 mmf., 20%, 500 V., ceramic
*RCN-053	C9	.047 mf., 200, 600 V., molded
*RCN-070	C6	.33 mf., 100 V., paper
RCT-077	C2A,B,C	Tuning capacitor
*RCW-3014	C5	.005 mf., +150%-0%, 450 V., cer.
*RCW-3018	C19	.002 mf., -0%+100%, 450 V., cer.
*RCW-3075	C4	47 mmf., disk ceramic
*RCW-3089	C14A,B,C	Bullplate - .002 mf., .005 mf, D 200 mf., .004 mf.
*RCW-3118	C8	.003 mf., 20%, 100 V., ceramic
RCW-3126	C11	220mmf., ceramic
POTENTIOMETER & RESISTORS		
RRC-253	R9,81	Volume Control and Switch
*RRW-042	R8	2300 ohms, ±10%, LOW., w.w.
*URD-031	R18	180 ohms, ±10%, 1/2 W., carbon
*URD-041	R16	470 ohms, ±10%, 1/2 W., carbon
*URD-053	R15,17	1500 ohms, ±10%, 1/2 W., carbon
*URD-073	R2	10K, ±10%, 1/2 W., carbon
*URD-085	R14	33K, ±10%, 1/2 W., carbon
*URD-097	R1	100K, ±10%, 1/2 W., carbon
URD-113	R12	470K, ±10%, 1/2 W., carbon
*URD-133	R4,7,11 13	3.3 megohms, ±10%, 1/2 W., carbon
*URD 141	R3	6.8 megohms, ±10%, 1/2 W., carbon
*URD-145	R10	10 megohms, ±10%, 1/2 W., carbon
*URE-059	R6	2700 ohms, ±10%, 1 W., carbon
*URF-025	R5	100 ohms, ±10%, 2 W., carbon

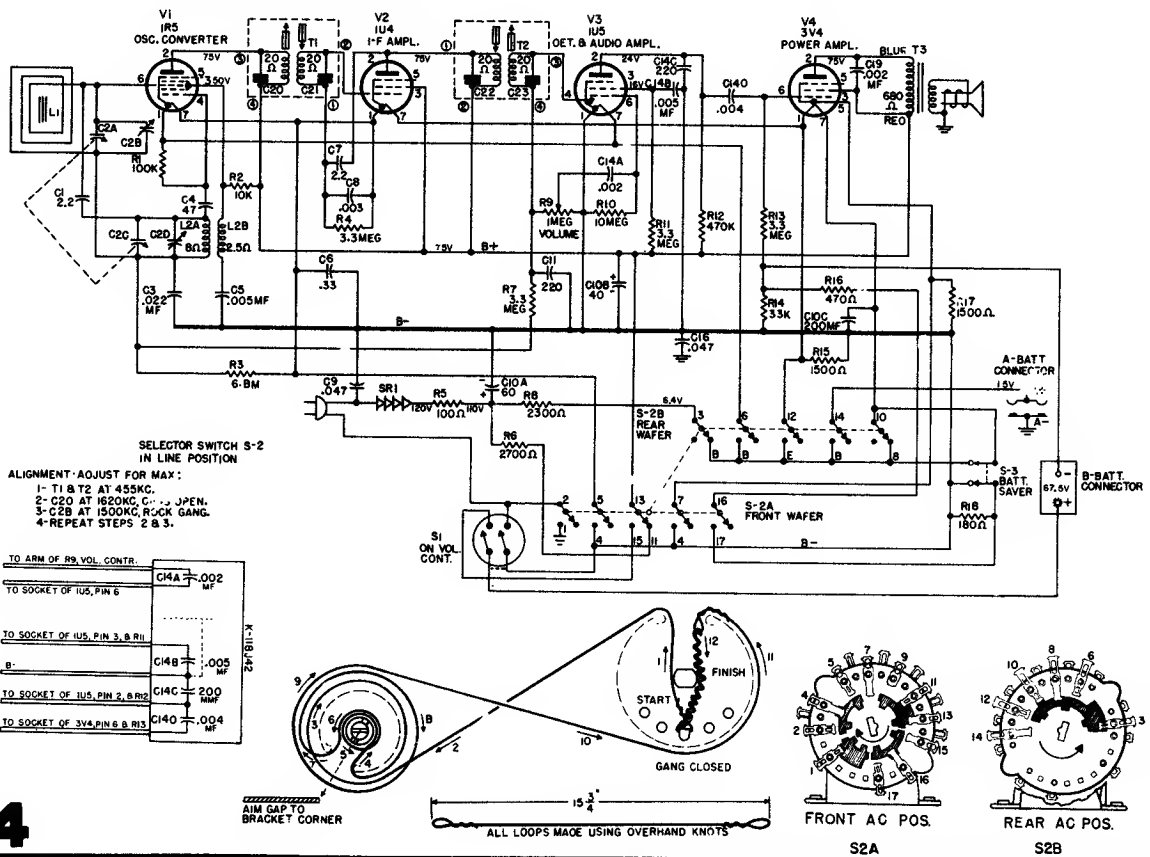

MANUAL OF 1954 MOST-OFTEN-NEEDED RADIO DIAGRAMS

the hallicrafters co.

MODEL TW-25 (Runs 1 & 2)

3-WAY PORTABLE RADIO

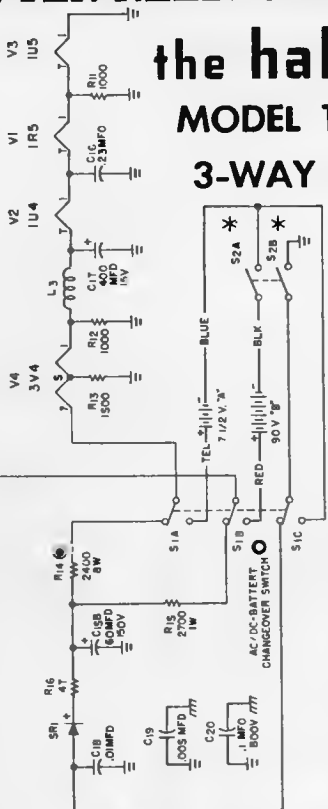
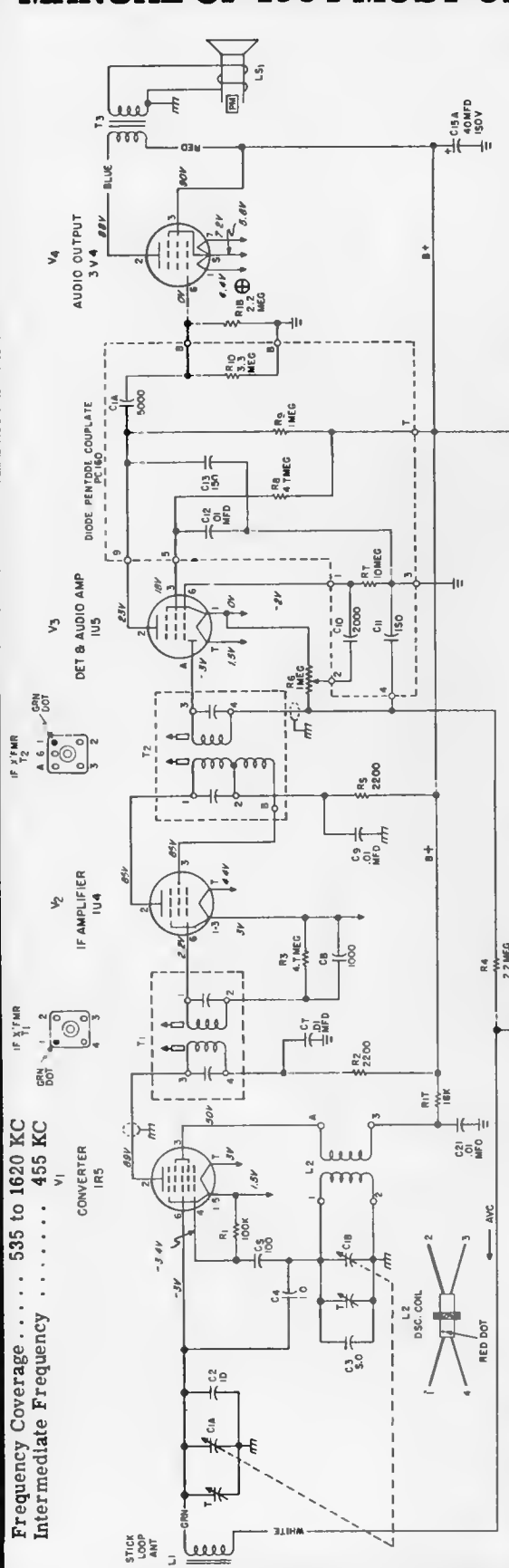

NOTES

1. RESISTANCE INDICATED IN OHMS AND CAPACITANCE IN MMF UNLESS OTHERWISE SPECIFIED.
2. RESISTORS HAVE 1/2 WATT RATING UNLESS OTHERWISE SPECIFIED.
3. INTERMEDIATE FREQUENCY - 455 KC.
4. LINE VOLTAGE - FOR AC/DC OPERATION - 117 VOLTS 50/60 CYCLES.
FOR BATTERY OPERATION - 1 1/2 V "A" AND 50 V "B"
5. ALL VOLTAGES ARE MEASURED WITH A VACUUM TUBE VOLTMETER (VTVM) AND ARE DC AND POSITIVE UNLESS OTHERWISE SPECIFIED
6. ALL VOLTAGES ARE MEASURED BETWEEN TUBE SOCKET TERMINALS AND B-(PHI OF IUS) WITH ANTENNA TERMINALS SHORTED AND TUNING GANG FULLY MESHED.
7. * K*1000
8. B-(COMMON GROUND)

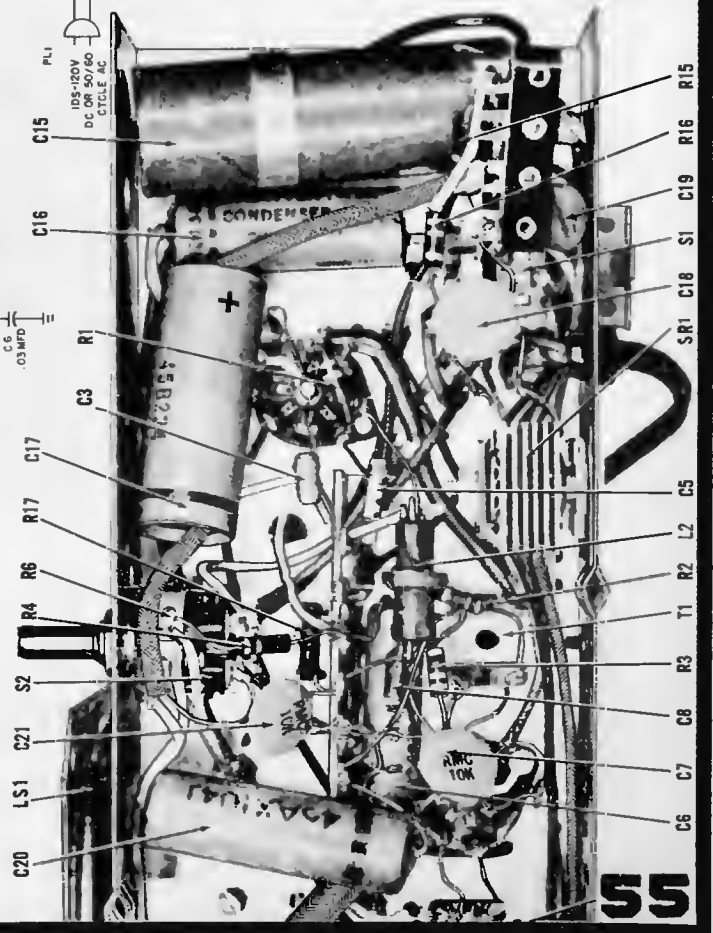

Frequency Coverage 535 to 1620 KC
Intermediate Frequency 455 KC

MANUAL OF 1954 MOST-OFTEN-NEEDED RADIO DIAGRAMS

MODELS 51C1, 51C1A, 51C2 & 51C2A

the hallicrafters

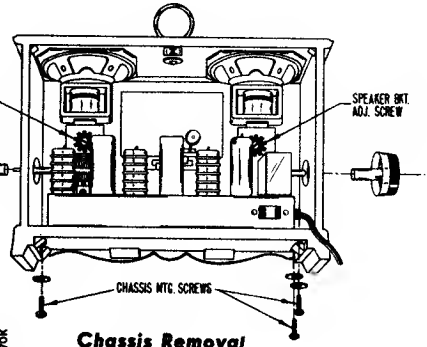

Chassis Removal

ALIGNMENT PROCEDURE

Step	Signal Generator Connections	Generator Frequency	Receiver Dial Setting	Adjust
1	High side thru .1 mfd. capacitor to stator plates of oscillator section of tuning gang. Low side to B- (point X).	455 KC	1000 KC	A-B (1st IF) and C-D (2nd IF)
2	Construct a loop of a few turns of wire and connect it to the signal generator. Loosely couple this loop to the loop antenna of the receiver.	1620 KC	Tuning gang fully open.	E (osc. trimmer)
3	Same as Step 2.	1400 KC	1400 KC	F (ant. trimmer)

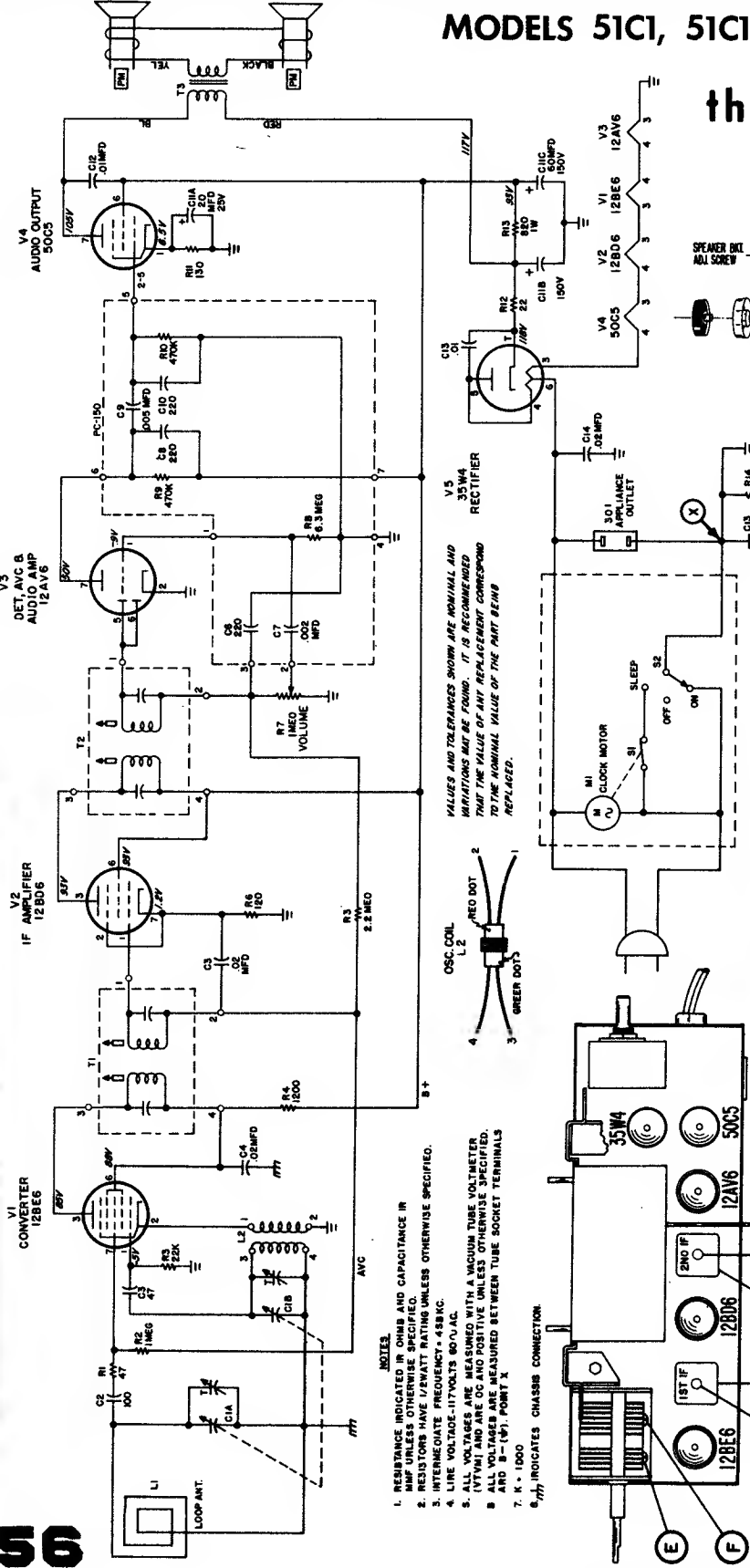

- NOTES:**
1. RESISTANCE INDICATED IN OHMS AND CAPACITANCE IN MMF UNLESS OTHERWISE SPECIFIED.
 2. RESISTORS HAVE 1/2WATT RATING UNLESS OTHERWISE SPECIFIED.
 3. INTERMEDIATE FREQUENCY - 455 KC.
 4. LINE VOLTAGE - 117 VOLTS 60/VA.C.
 5. ALL VOLTAGES ARE MEASURED WITH A VACUUM TUBE VOLTMETER.
 6. ALL VOLTAGES ARE DC AND POSITIVE UNLESS OTHERWISE SPECIFIED.
 7. K = 1000.
 8. --- INDICATES CHASSIS CONNECTION.

VALUES AND TOLERANCES SHOWN ARE NOMINAL AND VARIATIONS MAY BE FOUND. IT IS RECOMMENDED THAT THE VALUE OF ANY REPLACEMENT CORRESPOND TO THE NOMINAL VALUE OF THE PART BEING REPLACED.

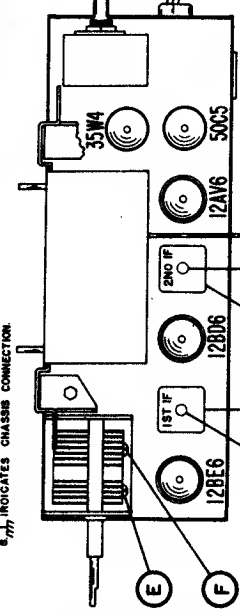
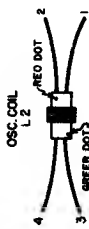

MANUAL OF 1954 MOST-OFTEN-NEEDED RADIO DIAGRAMS

the hallicrafters co.

MANUFACTURERS OF RADIO, TELEVISION AND ELECTRONIC EQUIPMENT, CHICAGO 24, U. S. A.

MODELS 611 AND 612 AC/DC RADIO RECEIVER

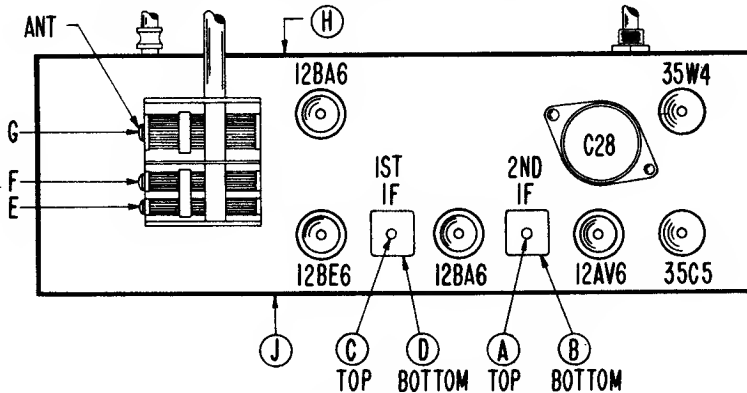

Fig. 2. Top View Alignment Locations

SPECIFICATIONS

- Tubes 6 tubes including rectifier
- Power 105-125 volts DC/50-60 cycle AC
32 watts
- Frequency Coverage . . . 535 to 1620 KC
- Intermediate Frequency 455 KC
- Speaker 4" x 6" oval PM
- Voice Coil Impedance 3.2 ohms

See next page, over, for a complete circuit diagram of Models 611, 612.

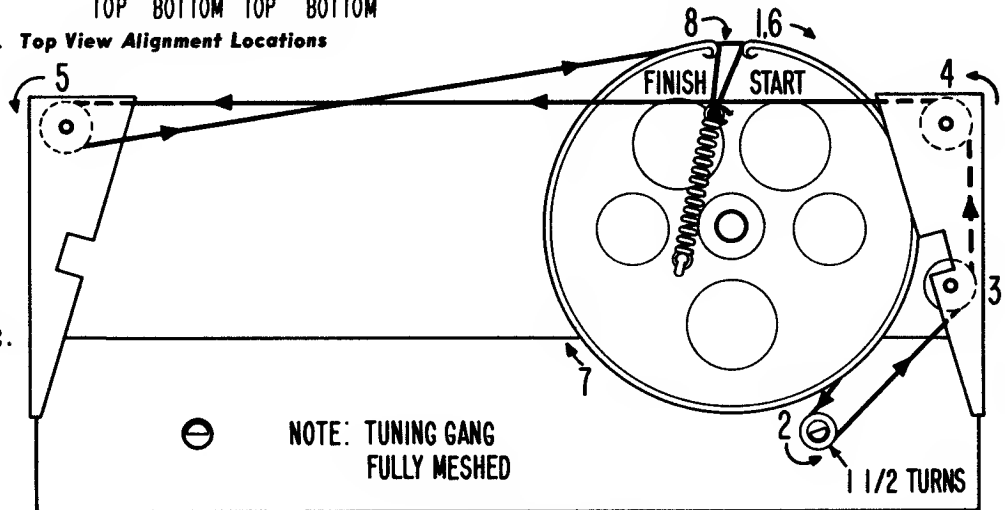

Fig. 3. Dial Stringing Detail

ALIGNMENT PROCEDURE

- Connect output meter across voice coil.
- Set volume control at maximum.
- Use a non-metallic alignment tool.
- Refer to Fig. 2 for location of alignment adjustments.
- Generator must have modulated output and cover 455 KC, 1400 KC and 1620 KC.
- To avoid AVC action use lowest output setting of generator that gives a satisfactory reading on meter.

Step	Signal Generator Connections	Generator Frequency	Receiver Dial Setting	Adjust
1	High side through .01 mfd. capacitor to pin 7 of V2. Low side to B-.	455 KC	Gang half meshed	A and B (2nd I-F) C and D (1st I-F)
2	Same as step 1	1620 KC	Gang fully open	E (Osc. trimmer)
3	High side through .01 mfd. capacitor to pin 1 of V1. Low side to B-.	1400 KC	Tune in gen. signal	F (Mixer trimmer)
4	Radiate generator signal into loop antenna.	1400 KC	Tune in gen. signal	G (Antenna trimmer)
5	Same as step 4.	600 KC	600 KC	H and J (osc/mixer slugs)
6	Repeat step 4.			

(Continued on the next page, over)

The Hallicrafters Co.
Models 611 and 612

(Continued from the
previous page).

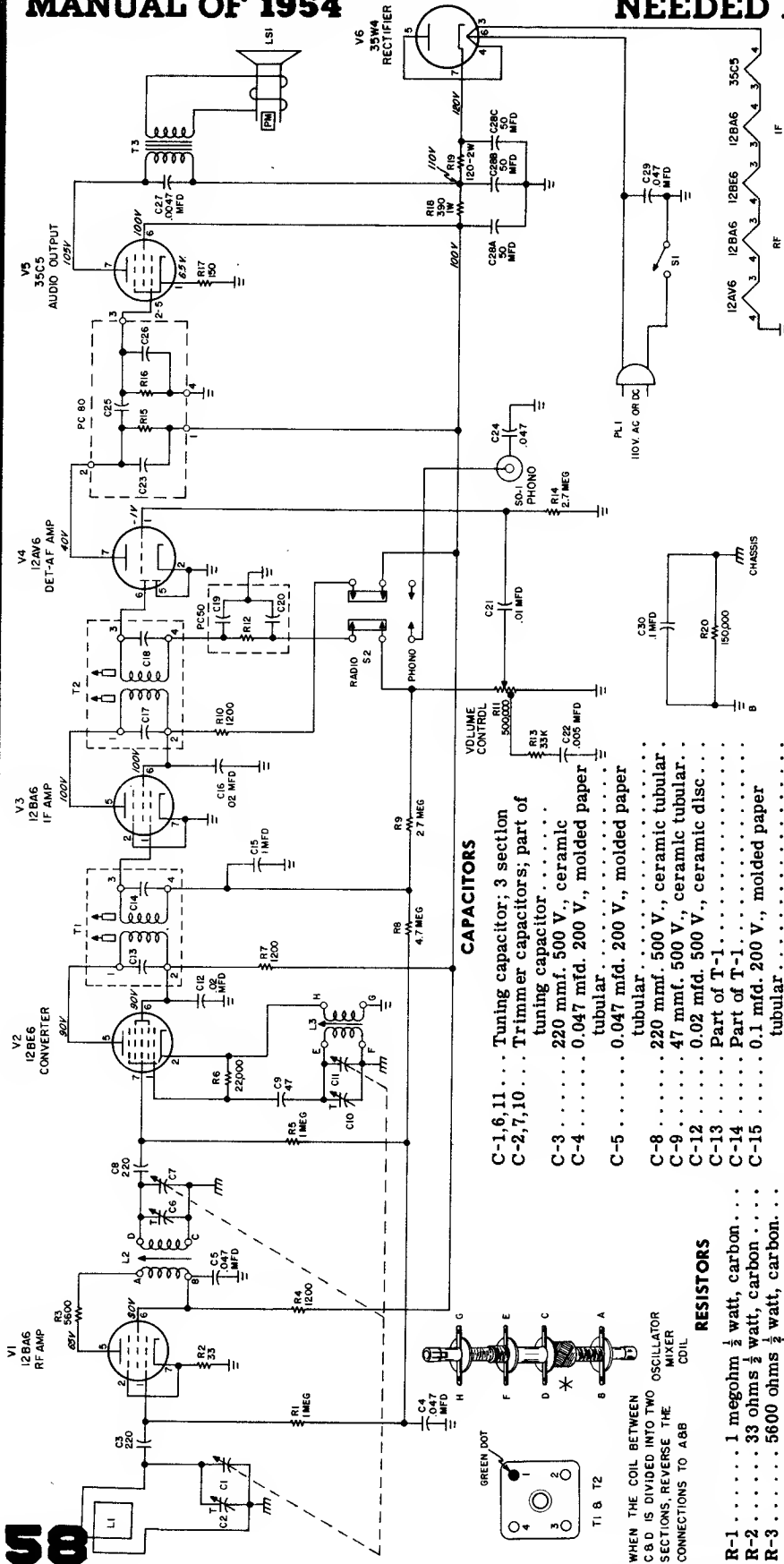

NOTES
ALL RESISTORS ARE 1/2 WATT UNLESS OTHERWISE SPECIFIED.
CAPACITOR VALUES ARE IN MMF UNLESS OTHERWISE SPECIFIED.
m indicates chassis ground.
B indicates electrical ground bus B-

VOLTAGES
VOLTAGE READINGS ARE TAKEN UNDER THE FOLLOWING CONDITIONS
1. LINE VOLTAGES - 117 VOLTS DC OR 50/60 CYCLE AC.
2. VOLTAGES ARE DC, UNLESS OTHERWISE SPECIFIED.
3. DC VOLTAGES ARE MEASURED WITH VTVM BETWEEN THE TUBE SOCKET TERMINALS AND B- ().

CAPACITORS

- C-1,6,11... Tuning capacitor; 3 section
- C-2,7,10... Trimmer capacitors; part of tuning capacitor
- C-3... 220 mmf, 500 V, ceramic
- C-4... 0.047 mfd, 200 V, molded paper tubular
- C-5... 0.047 mfd, 200 V, molded paper tubular
- C-8... 220 mmf, 500 V, ceramic tubular
- C-9... 47 mmf, 500 V, ceramic tubular
- C-12... 0.02 mfd, 500 V, ceramic disc
- C-13... Part of T-1
- C-14... Part of T-1
- C-15... 0.1 mfd, 200 V, molded paper tubular
- C-16... 0.02 mfd, 500 V, ceramic disc
- C-17... Part of T-2
- C-18... Part of T-2
- C-19... Part of couple PC-50
- C-20... Part of couple PC-50
- C-21... 0.01 mfd, 500 V, ceramic disc
- C-22... 0.005 mfd, 500 V, ceramic disc
- C-23... Part of couple PC-80
- C-24... 0.047 mfd, 200 V, molded paper tubular
- C-25... Part of couple PC-80
- C-26... Part of couple PC-80
- C-27... 0.0047 mfd, 400 V, paper tubular
- C-28... 50-50-50 mfd, 150 V, electrolytic
- C-29... 0.047 mfd, 400 V, molded paper
- C-30... 0.1 mfd, 600 V, molded paper

RESISTORS

- R-1... 1 megohm 1/2 watt, carbon
- R-2... 33 ohms 1/2 watt, carbon
- R-3... 5600 ohms 1/2 watt, carbon
- R-4... 1200 ohms 1/2 watt, carbon
- R-5... 1 megohm 1/2 watt, carbon
- R-6... 22,000 ohms 1/2 watt, carbon
- R-7... 1200 ohms 1/2 watt, carbon
- R-8... 4.7 megohms 1/2 watt, carbon
- R-9... 2.7 megohms 1/2 watt, carbon
- R-10... 1200 ohms 1/2 watt, carbon
- R-11... 500,000 ohms volume control
- R-12... Part of couple PC-50
- R-13... 33,000 ohms 1/2 watt, carbon
- R-14... 2.7 megohms 1/2 watt, carbon
- R-15... Part of couple PC-80
- R-16... Part of couple PC-80
- R-17... 150 ohms 1/2 watt, carbon
- R-18... 390 ohms 1 watt, carbon
- R-19... 120 ohms 2 watt, carbon
- R-20... 150,000 ohms 1/2 watt, carbon

WHEN THE COIL BETWEEN C&D IS DIVIDED INTO TWO OSCILLATOR SECTIONS, REVERSE THE MIXER CONNECTIONS TO A&B

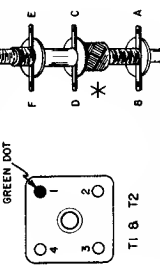

MANUAL OF 1954 MOST-OFTEN-NEEDED RADIO DIAGRAMS

M O N T G O M E R Y W A R D

TABLE RADIO

MODEL NO.
25BR-1542A

Alignment must be done in the cabinet.

The signal source must be an accurately calibrated signal generator capable of supplying 455 Kc and up to 1620 Kc signals modulated 30% with a 400-cycle audio signal.

To connect the output meter, disconnect the speaker and substitute a 3.2 ohm, 5 watt resistor across the secondary winding of the output transformer. Connect output meter across 3.2 ohm resistor.

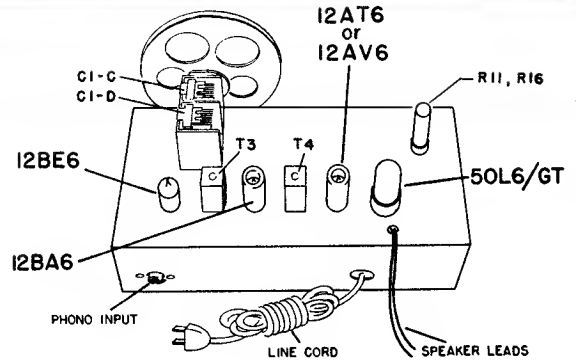

- Volume control at maximum for all adjustments.
- Align for maximum output. Reduce input as needed to keep output near 0.4 volts.
- Loop antenna should be connected to receiver and in its proper position when making adjustments.

SIGNAL GENERATOR				TUNER SETTING	ADJUST FOR MAXIMUM OUTPUT
Frequency	Coupling Capacitor	Connection to Radio	Ground Connection		
455 kc.	.1 mf.	12BE6, Pin 7	B MINUS POINT BUSS LEAD	Capacitor fully open (plates out of mesh)	Top and bottom Cores in output and input I.F. cans
1620 kc.	.1 mf.	12BE6, Pin 7		Capacitor fully open (plates out of mesh)	Oscillator trimmer C1-D on gang
535 kc.	.1 mf.	12BE6, Pin 7		Capacitor fully closed	Check for adequate range
1400 kc.	—	Lay Generator lead near back of cabinet.		Set dial pointer at 1400 kc.	Antenna trimmer C1-C on gang

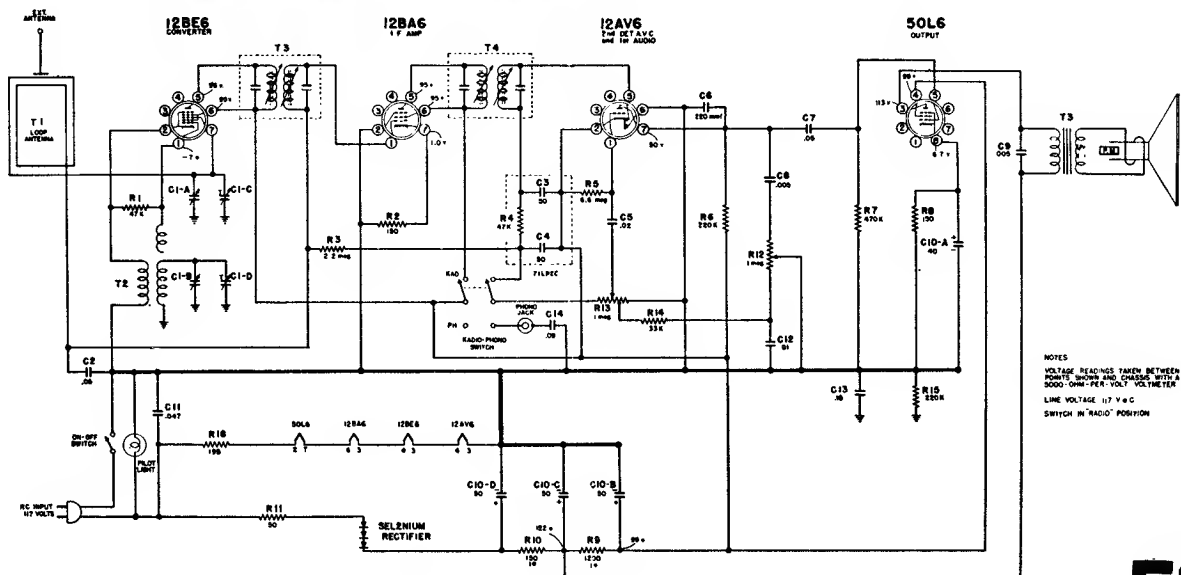

NOTES
VOLTAGE READINGS TAKEN BETWEEN POINTS SHOWN AND CHOSEN WITH A 5000-OHM-PER-VOLT VOLTMETER
LINE VOLTAGE 117 V_{AC}
SWITCH IN "RADIO" POSITION

MANUAL OF 1954 MOST-OFTEN-NEEDED RADIO DIAGRAMS

Montgomery Ward & Co.
Model 25GSL-1072A

Airline
PORTABLE RADIO

Model No.
25GSL-1072A

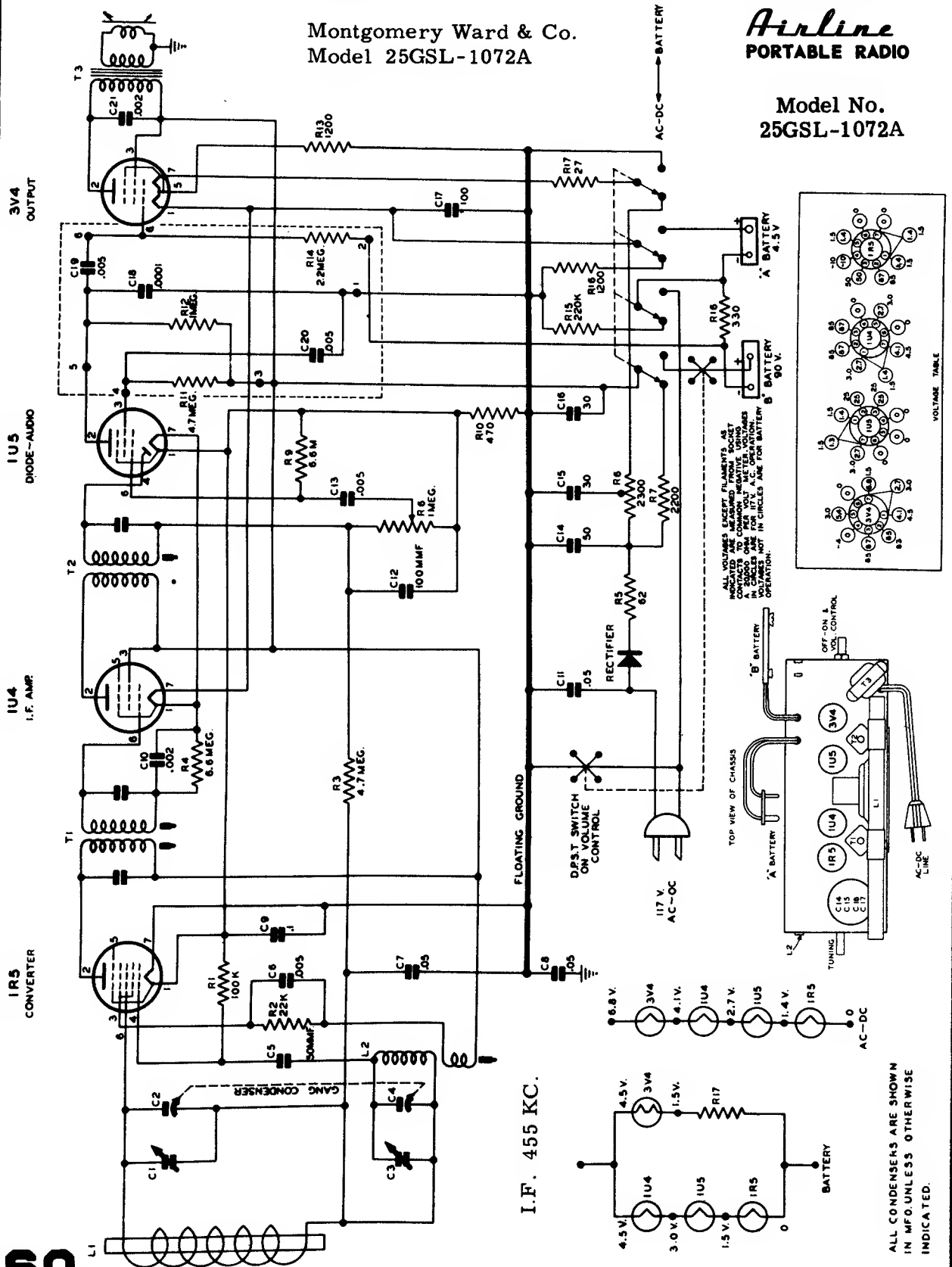

MANUAL OF 1954 MOST-OFTEN-NEEDED RADIO DIAGRAMS

M O N T G O M E R Y W A R D

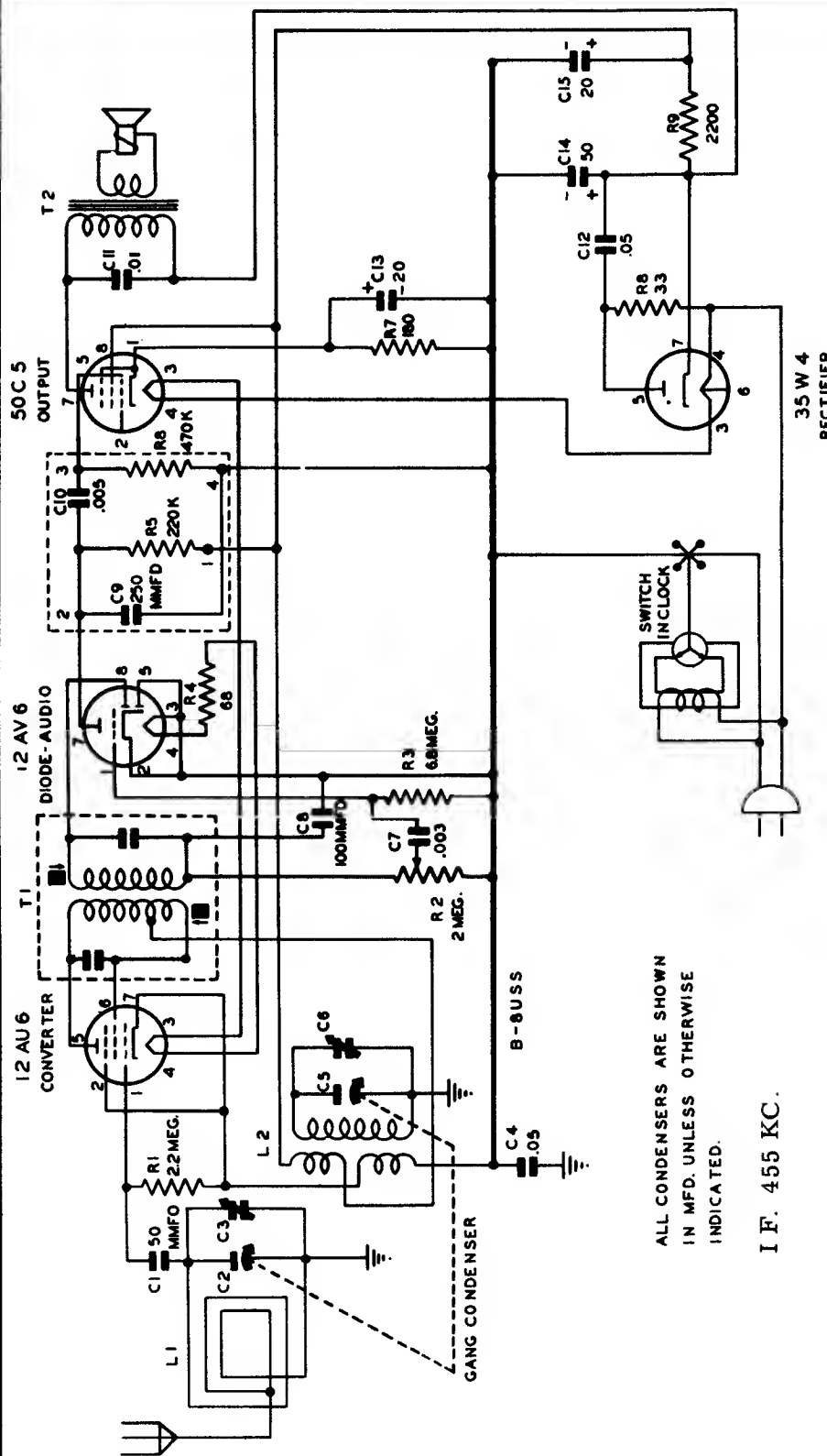

Airline
CLOCK RADIO
 Model Nos.
 25GSL - 1560A
 25GSL - 1561A

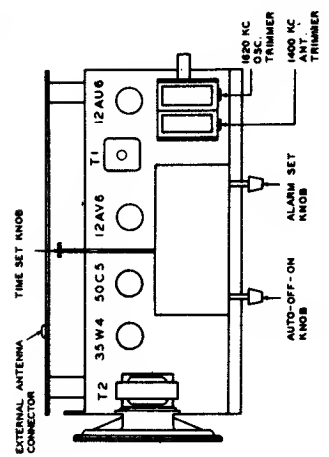
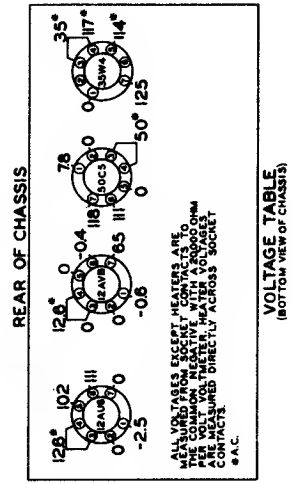

ALL CONDENSERS ARE SHOWN
 IN MFD. UNLESS OTHERWISE
 INDICATED.

I.F. 455 KC.

MANUAL OF 1954 MOST-OFTEN-NEEDED RADIO DIAGRAMS

MOTOROLA, INC.

MODEL CTA3

TYPE - Automotive, single unit superheterodyne receiver with external speaker. Has push-button tuning. Specifically designed for installation in the 1953 Chevrolet cars.

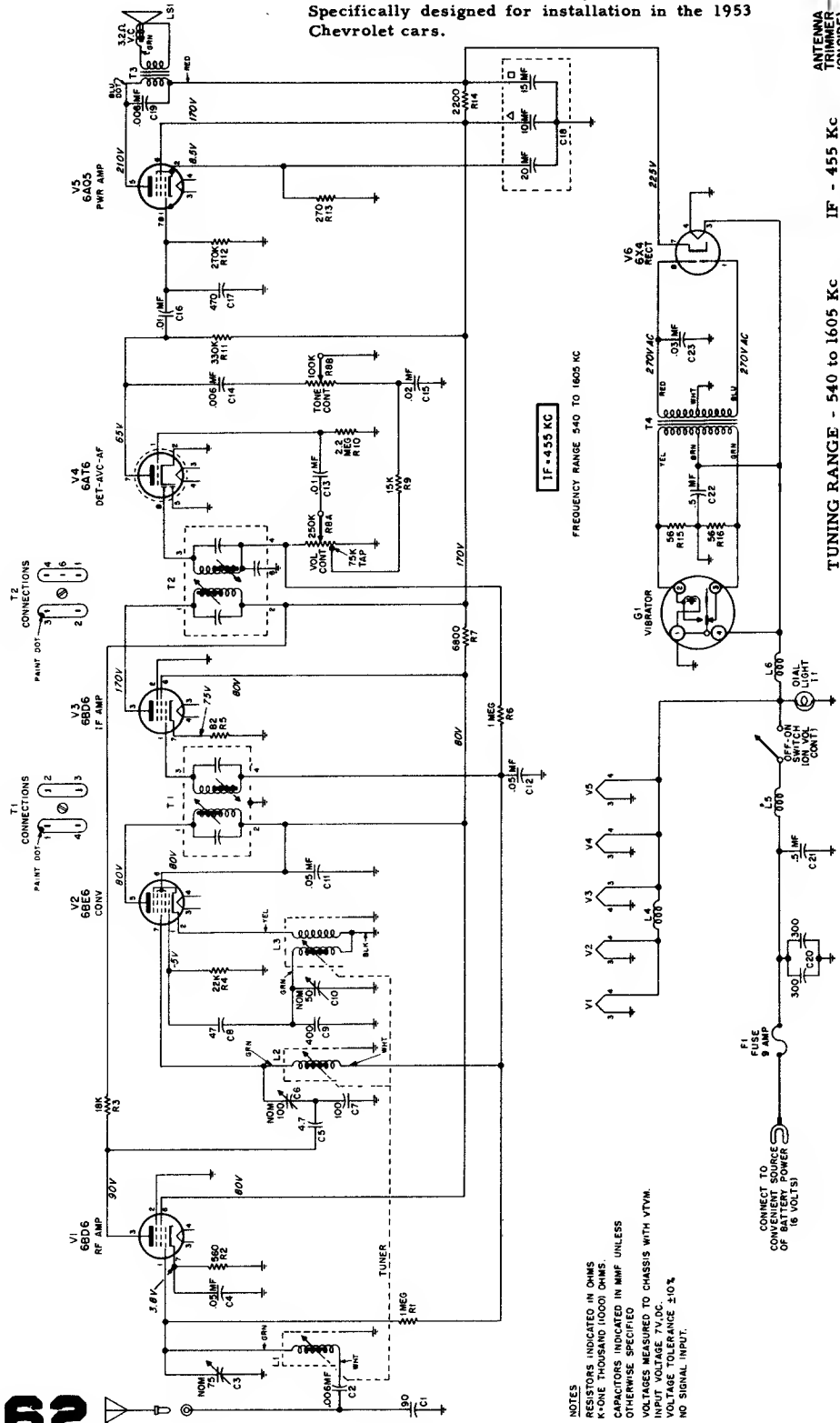

62

NOTES
 RESISTORS INDICATED IN OHMS
 K-ONE THOUSAND (1000) OHMS.
 CAPACITORS INDICATED IN MMF UNLESS
 OTHERWISE SPECIFIED
 VOLTAGES MEASURED TO CHASSIS WITH VTVM.
 INPUT VOLTAGE 7V.D.C.
 VOLTAGE TOLERANCE $\pm 10\%$
 NO SIGNAL INPUT.

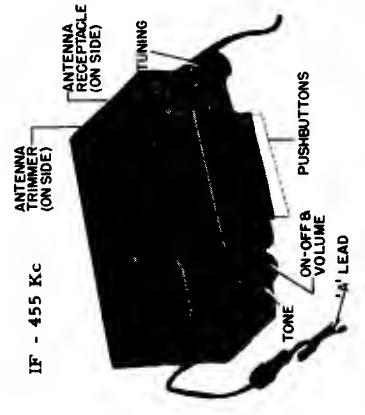

TUNING RANGE - 540 TO 1605 KC
 IF - 455 KC

TO SET PUSHBUTTONS

- This receiver has a "Quick Set" Automatic tuner, with 5 "Push-to-Lock" pushbuttons for automatic station selection.
- To set the pushbuttons for automatic tuning, proceed as follows:
1. Tune in the desired station with the manual tuning knob.
 2. Pull out the first pushbutton to be set, to unlock the button for station set-up, and then push button in firmly to set and lock the button.
 3. Follow the above procedure for the remaining four buttons.
- Tune carefully until you are exactly on the station.

MANUAL OF 1954 MOST-OFTEN-NEEDED RADIO DIAGRAMS

MOTOROLA, INC.

CHASSIS R17A6 R16M6

TYPE - Chassis R17A6 (with mechanical pushbuttons) and R16M6 are four-tube automotive type tuner chassis. Each contain an RF amp, converter, IF amp, detector and 1st AF amplifier stages.

Each Tuner Unit above must be used with a separate Audio & Power Unit (Motorola Models P6-2 or P8-2) to form a complete radio receiver.

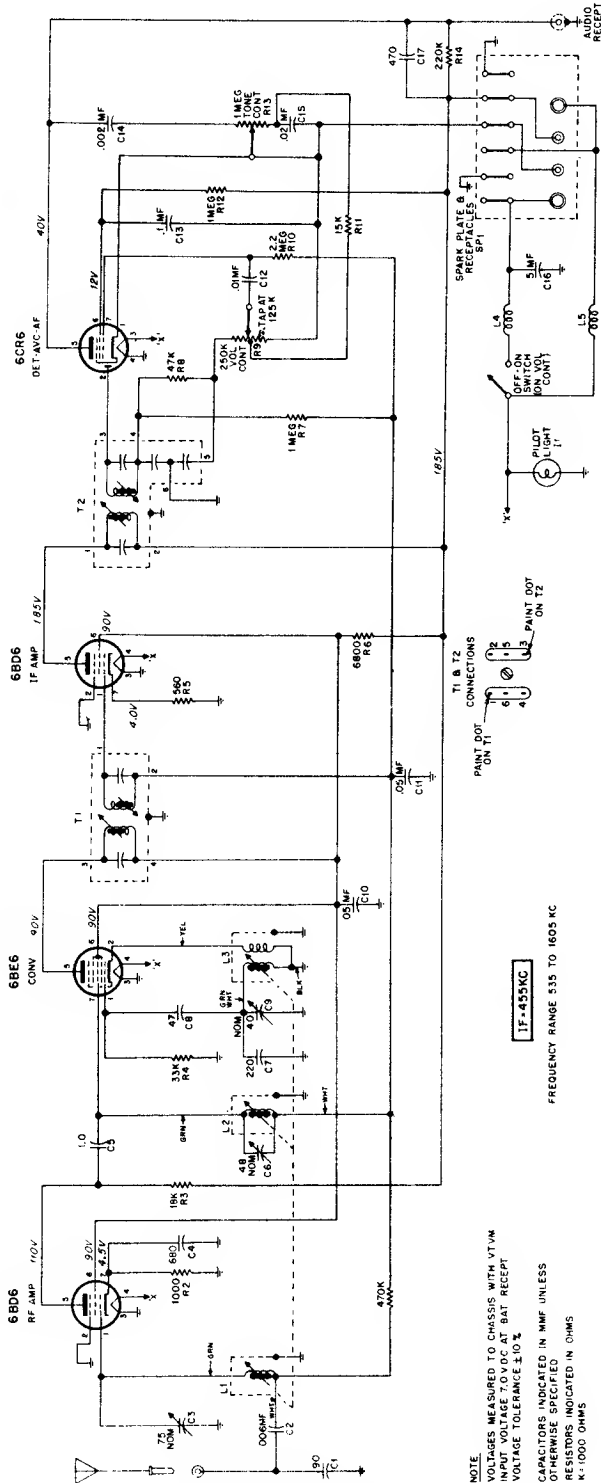

R17A6 SCHEMATIC DIAGRAM

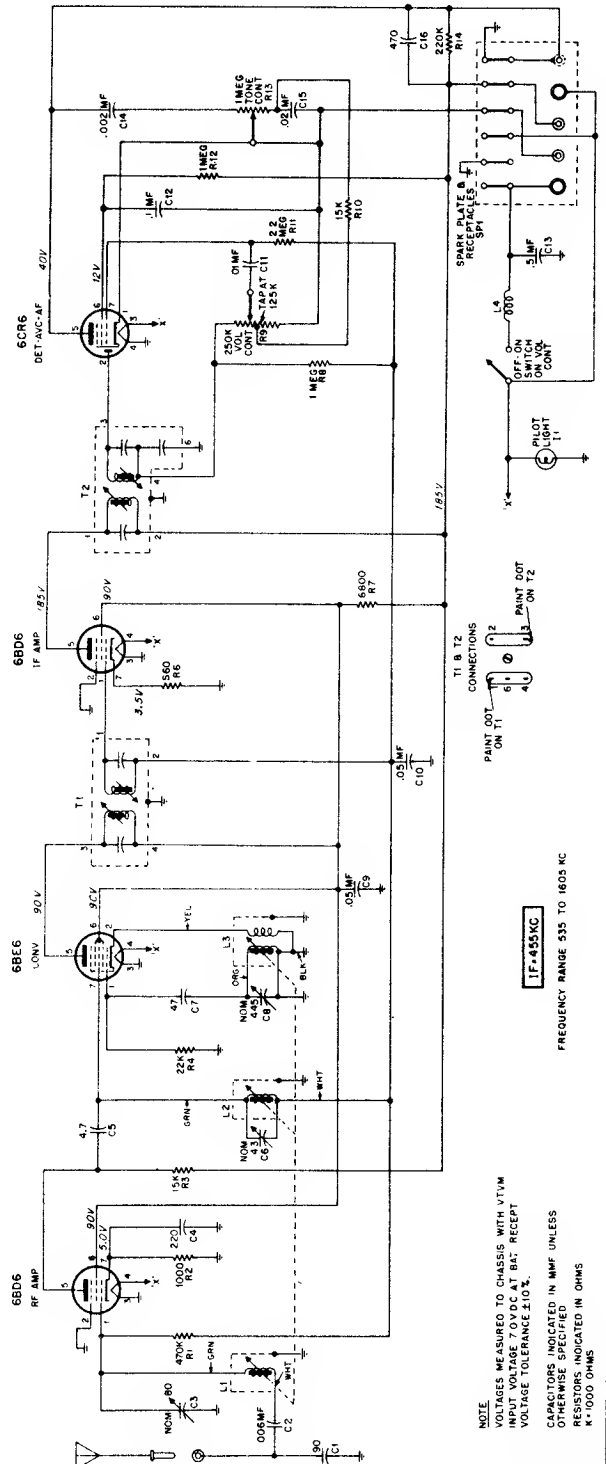

R16M6 SCHEMATIC DIAGRAM

MANUAL OF 1954 MOST-OFTEN-NEEDED RADIO DIAGRAMS

MOTOROLA, INC. CHASSIS R15A6

MODELS: BK3A6, CT2A6, GMT3A6, HJ3A6, HN2A6, HN3A6, HT3A6, KR3A6, OE2A6, PC2A6, PD3A6, SR2A6 & SR3A6

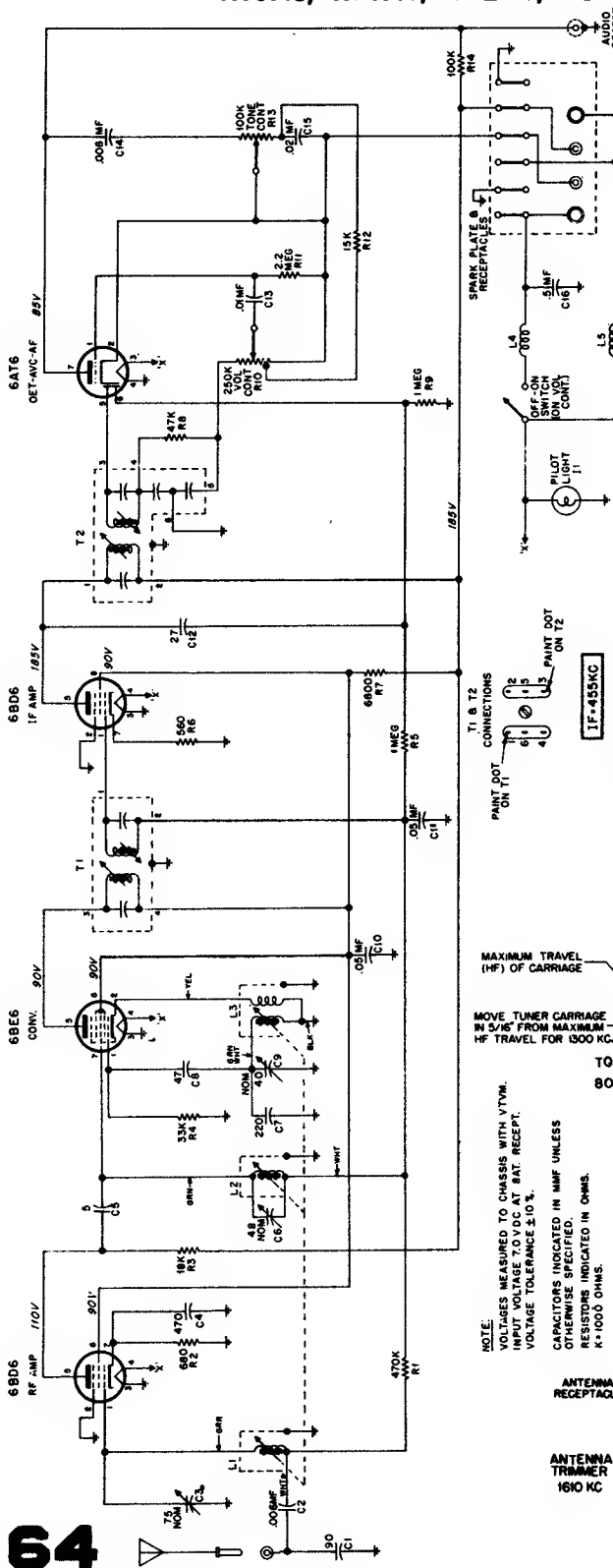

TYPE - Chassis R15A6 is a four-tube automotive type tuner chassis with mechanical pushbuttons. It contains the RF amp, converter, IF amp, detector, and 1st AF amplifier stages.

The Tuner Units must be used with a separate Audio & Power Unit (Motorola Models P6-2 or P8-2) to form a complete radio receiver.

For data on Models P6-2 and P8-2 see page 94 in Supreme 1952 RADIO Manual.

MODEL	FOR CAR	CAR YEAR
BK3A6	Buick Special Buick Super & Roadmaster	1953, 1952, 1951, 1950, 1949
		1952, 1951, 1950, 1949, 1948, 1946, 1947 & 1942
CT2A6 GMT3A6	Chevrolet GM & Chev- rolet Truck	1952 & 1951
		1953, 1952, 1951, 1950, 1949 & 1948
HJ3A6 HN2A6 HN3A6	Henry J. Hudson Hudson (ex- cept Hudson Jet)	1953, 1952 & 1951
		1952 & 1951
HT3A6 KR3A6 OE2A6	Hudson Jet Kaiser Oldsmobile "88" Super Oldsmobile "98" Series	1953
		1953, 1952, 1951
PC2A6 PD3A6 SR2A6 SR3A6	Pontiac Packard Studebaker Studebaker	1952 & 1951
		1952, 1951, 1950 & 1949 1953, 1952 & 1951 1952, 1951 & 1950 1953

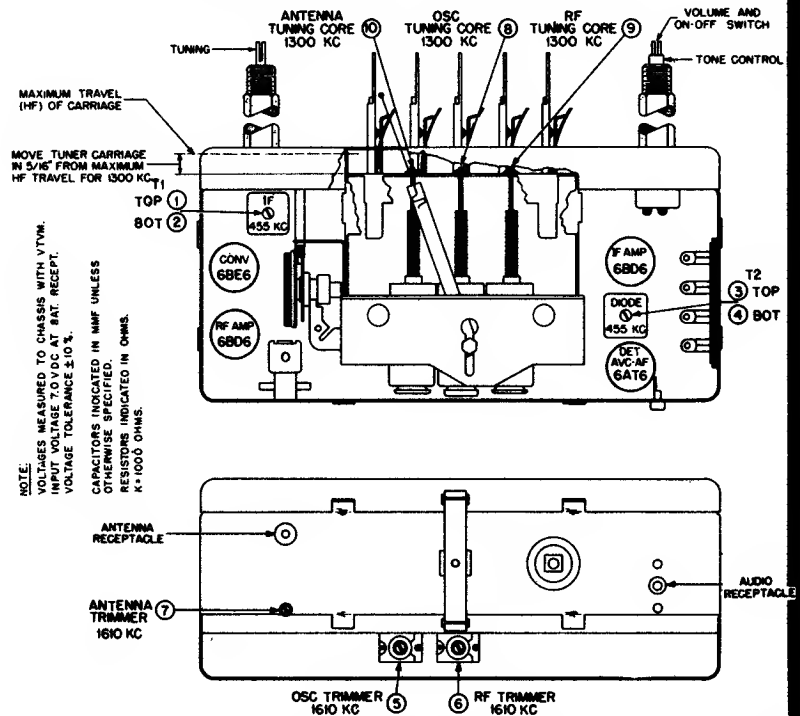
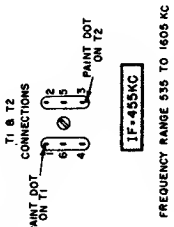

MANUAL OF 1954 MOST-OFTEN-NEEDED RADIO DIAGRAMS

SECTION II CHASSIS R14M6

MODELS: BK3M6, CT2M6, GMT2M6, GMT3M6, HJ3M6, HN2M6, HN3M6, HT3M6, KR3M6, OE2M6, PC2M6, PD3M6, SR2M6, SR3M6

TYPE - Chassis R14M6 is a four-tube automotive type tuner chassis. It contains the RF amp, converter, IF amp, detector and 1st AF amplifier stages.

The above Tuner Units must be used with a separate Audio & Power Unit (Motorola Models P6-2 or P8-2) to form a complete radio receiver.

For data on Models P6-2 and P8-2 see page 94 in the 1952 RADIO Manual.

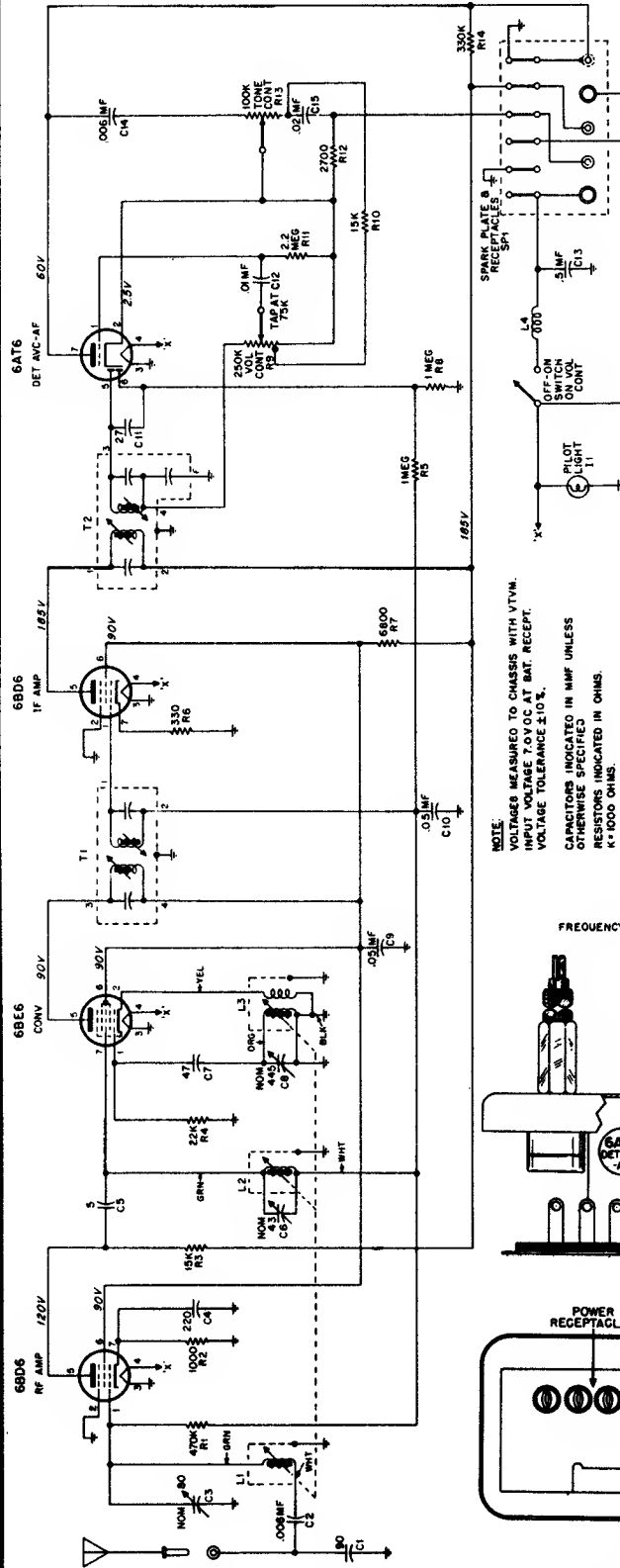

NOTE:
 VOLTAGES MEASURED TO CHASSIS WITH VTVM.
 INPUT VOLTAGE 7.0V OC AT BAT. RECEPT.
 VOLTAGE TOLERANCE ±10%.
 CAPACITORS INDICATED IN MHF UNLESS OTHERWISE SPECIFIED.
 RESISTORS INDICATED IN OHMS.
 R=1000 OHMS.

MODEL	FOR CAR	CAR YEAR
BK3M6	Buick Special	1953, 1952, 1951, 1950 & 1949
	Buick Super & Roadmaster	1952, 1951, 1950, 1949, 1948, 1947, 1946 & 1942
CT2M6 GMT2M6 & GMT3M6	Chevrolet	1952 & 1951
	GM & Chevrolet Truck	1953, 1952, 1951, 1950, 1949 & 1948
HJ3M6 HN2M6 HN3M6	Henry J. Hudson	1953, 1952 & 1951
	Hudson (except Hudson Jet)	1953, 1952 & 1951
HT3M6 KR3M6 OE2M6	Hudson Jet	1953
	Kaiser Oldsmobile "88" Super Oldsmobile "98" Series	1953, 1952 & 1951 1952 & 1951 1952
PC2M6 PD3M6 SR2M6 SR3M6	Pontiac	1952, 1951, 1950 & 1949
	Packard Studebaker Studebaker	1953, 1952 & 1951 1952, 1951 & 1950 1953

IF-455KC

FREQUENCY RANGE 535 TO 1605 KC

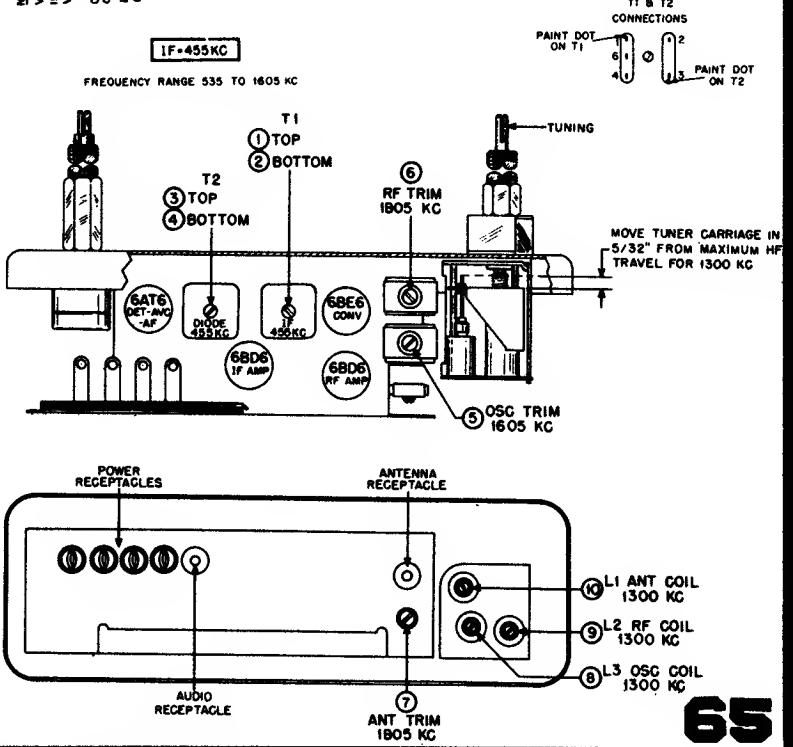

Motorola

MODELS
54L1 54L4
54L2 54L5
54L3 54L6

CHASSIS
HS-414

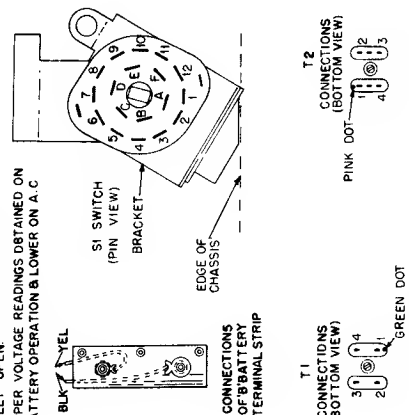
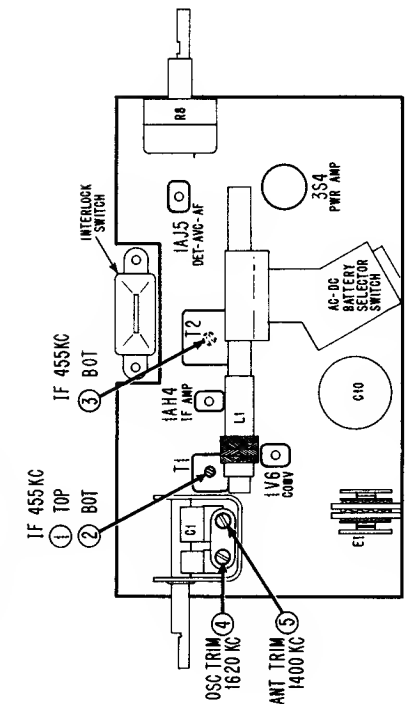
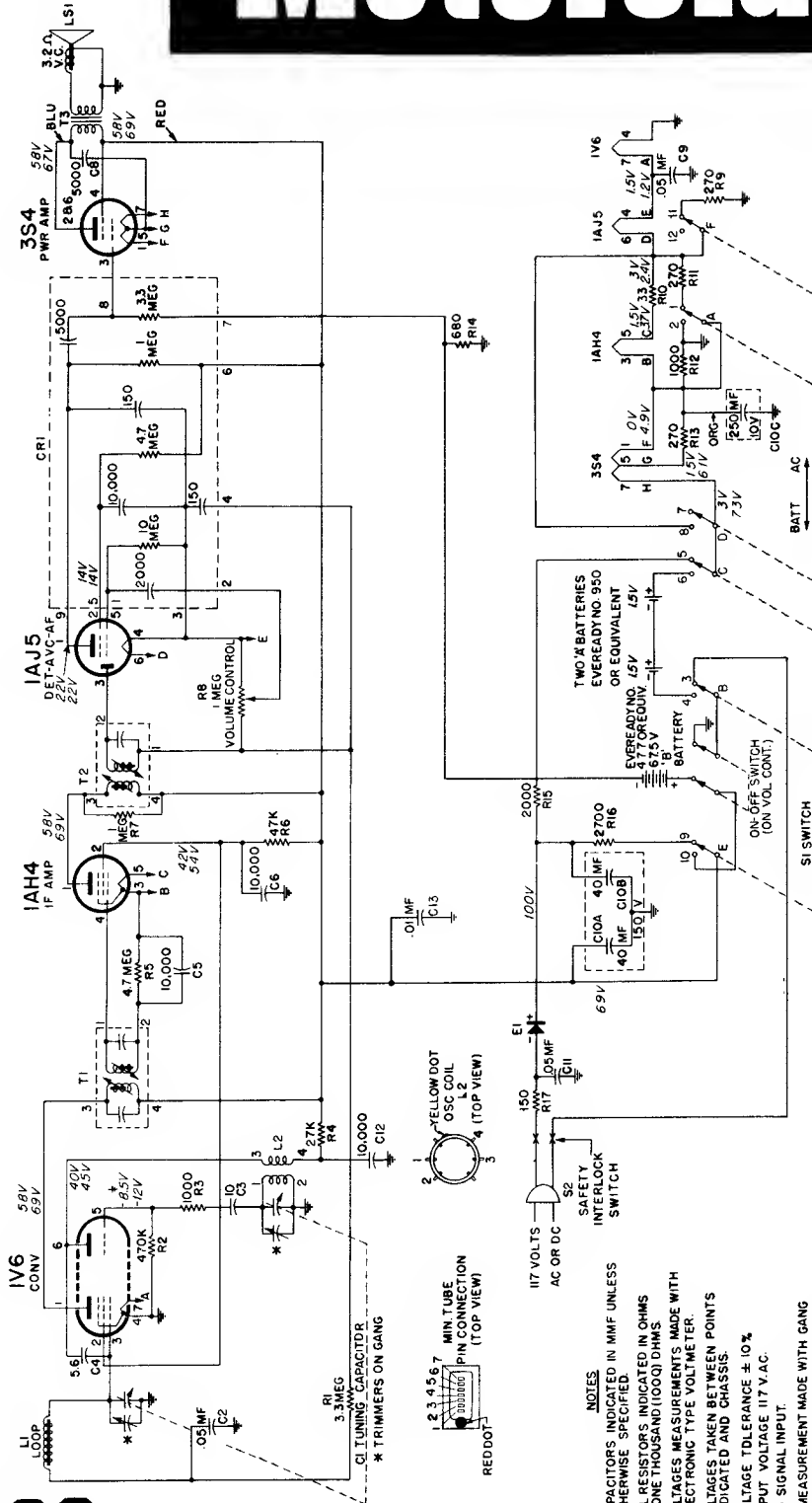

NOTES
 CAPACITORS INDICATED IN MMF UNLESS OTHERWISE SPECIFIED
 ALL RESISTORS INDICATED IN OHMS
 K-ONE THOUSAND (1000) OHMS
 M-ONE THOUSAND (1000) OHMS
 VOLTAGES MEASUREMENTS MADE WITH ELECTRONIC TYPE VOLTMETER.
 VOLTAGES TAKEN BETWEEN POINTS INDICATED AND CHASSIS.
 VOLTAGE TOLERANCE ± 10%
 INPUT VOLTAGE 117V. AC.
 NO SIGNAL INPUT.
 T MEASUREMENT MADE WITH GANG FULLY OPEN.
 UPPER VOLTAGE READINGS OBTAINED ON BATTERY OPERATION & LOWER ON A.C.

MANUAL OF 1954 MOST-OFTEN-NEEDED RADIO DIAGRAMS

MOTOROLA, INC.

(Additional service data is on the next page, over.)

CHASSIS
HS-366

MODELS

53C1
53C2
5353
53C4

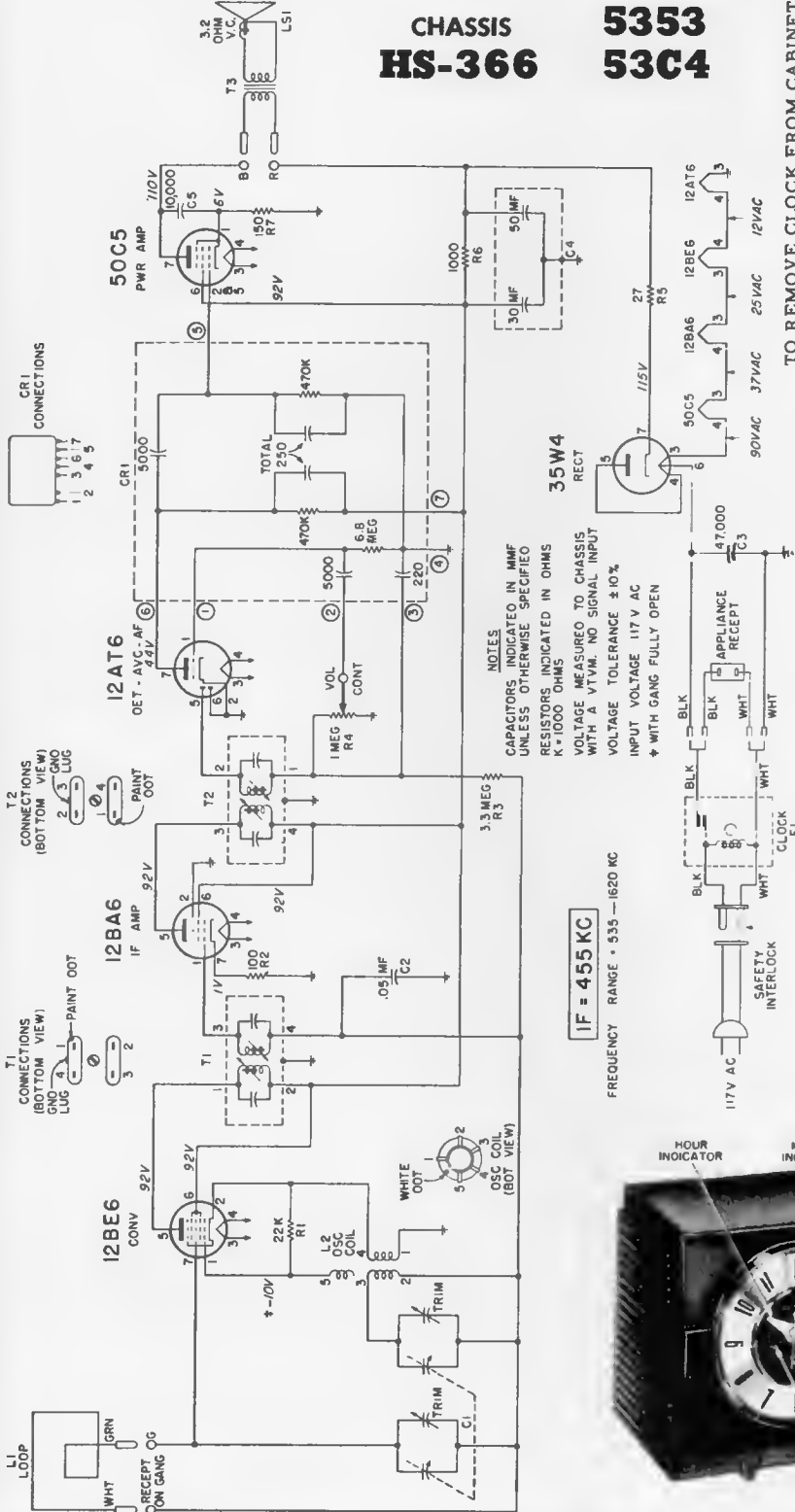

NOTES
CAPACITORS INDICATED IN MMF UNLESS OTHERWISE SPECIFIED
RESISTORS INDICATED IN OHMS
VOLTAGE MEASURED TO CHASSIS WITH A VTVM. NO SIGNAL INPUT
TOLERANCE $\pm 10\%$
INPUT VOLTAGE 117 V AC
* WITH GANG FULLY OPEN

TO REMOVE CLOCK FROM CABINET

1. Remove the two speaker mounting screws and remove speaker.
2. Pull off the operation selector knob on front of cabinet.
3. Remove the four screws that hold the clock bracket to the cabinet.
4. Carefully remove the clock and clock bracket from the cabinet.
5. Unsolder leads and remove the two small nuts and washers mounting the clock to the clock bracket.

CIRCUIT DESCRIPTION

1. The circuit of this chassis is conventional - there are no built-in resistors or capacitors. Leads are plated on both sides of the chassis base, thereby replacing the usual connecting wires and making wiring more uniform.
2. The metal plating extends through all the holes on the chassis, connecting circuits on the front with those on the rear.

TO REMOVE RADIO CHASSIS FROM CABINET

1. Remove the four screws which hold the rear cover; disconnect the antenna and appliance outlet leads and remove the cover.
2. Pull off the two control knobs from the front of the cabinet.
3. Remove the Phillips head screw under the tuning knob on the front of the receiver.
4. Disconnect the chassis power leads from clock.
5. Disconnect speaker leads from chassis.
6. From the back, remove the three screws that mount the chassis to the cabinet.
7. Remove the chassis from the cabinet.

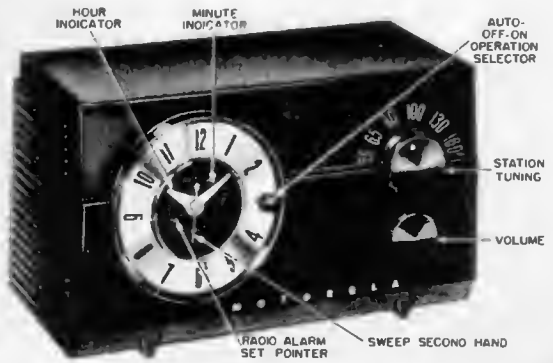

(Continued on the next page, over.)

MANUAL OF 1954 MOST-OFTEN-NEEDED RADIO DIAGRAMS

MOTOROLA, INC. MODELS **53C1**
53C2
HS-366 5353
53C4

(Continued from preceding page.)

CHASSIS
HS-366

2. WHEN REMOVING DEFECTIVE COMPONENTS, USE ONLY A SMALL SOLDERING IRON (60 WATTS OR LESS) TO AVOID DAMAGE TO THE WIRING. DO NOT USE A SOLDERING GUN. WARNING: THE LEADS ARE VERY THIN, AND EXCESSIVE HEAT WILL BURN THEM OR LOOSEN THEM FROM THE BASE MATERIAL.

SAFETY PRECAUTIONS

1. The chassis of this receiver is connected directly to the power line. However, the power cord circuit is broken by an interlock when the cabinet back is removed for replacing tubes. When aligning or servicing the chassis from AC, an isolation transformer should be inserted between the power line and the chassis.
2. Do not service the chassis on a metal plate, because of the possibility of a short circuit.
3. Use caution when handling the chassis with power applied, because all high voltage leads are exposed.
4. The outer edges of the chassis and the large plated areas in the center are at ground potential.

3. Plated connections or leads, if damaged, may be replaced with a jumper of regular hook-up wire.

4. It is recommended that IF transformers, tuning capacitor, volume control, oscillator coil, or the electrolytic capacitor be removed by immersing all the lugs simultaneously into a small soldering pot. The component may then be lifted off the chassis easily. If a soldering pot is not available, heat each lug individually with a small soldering iron, and shake off as much molten solder as possible. Then, by alternately heating and loosening each lug, the entire component will be freed. The disadvantage of using a soldering iron instead of a soldering pot is that the plated connections may be pulled loose from the chassis.

5. An individual tube clip may be removed by squeezing it with pliers and then unsoldering it. The new clip snaps into the hole.

6. Resistors or capacitors may be removed by unsoldering one end at a time.

COMPONENT REPLACEMENT

1. To prevent tube breakage, remove them before replacing components. CAUTION: Remove the tubes only by pulling them straight out. Wiggling a tube may bend a socket clip, causing poor contact with the tube pin.

CAUTION: Clean all the solder from the holes before installing a new component. Do not let the solder run onto an adjacent lead, as a short circuit will be created.

ALIGNMENT CHART

STEP	DUMMY ANTENNA	GENERATOR CONNECTION	GENERATOR FREQUENCY	GANG SETTING	ADJUST	REMARKS
IF ALIGNMENT						
1.	.1 mf	Grid of conv. (pin 7, 12BE6)	455 Kc	Fully open	1, 2, 3, & 4 (IF cores)	Adjust for maximum.
RF ALIGNMENT						
2.	.1 mf	Grid of conv. (pin 7, 12BE6)	1620 Kc	Fully open	5 (Osc)	Adjust for maximum.
3.		Radiation loop*	1400 Kc	Tune for max	6 (Ant)	Adjust for maximum.

*Connect generator output across 5" diameter, 5 turn loop and couple inductively to receiver loop. Keep loops at least 12" apart.

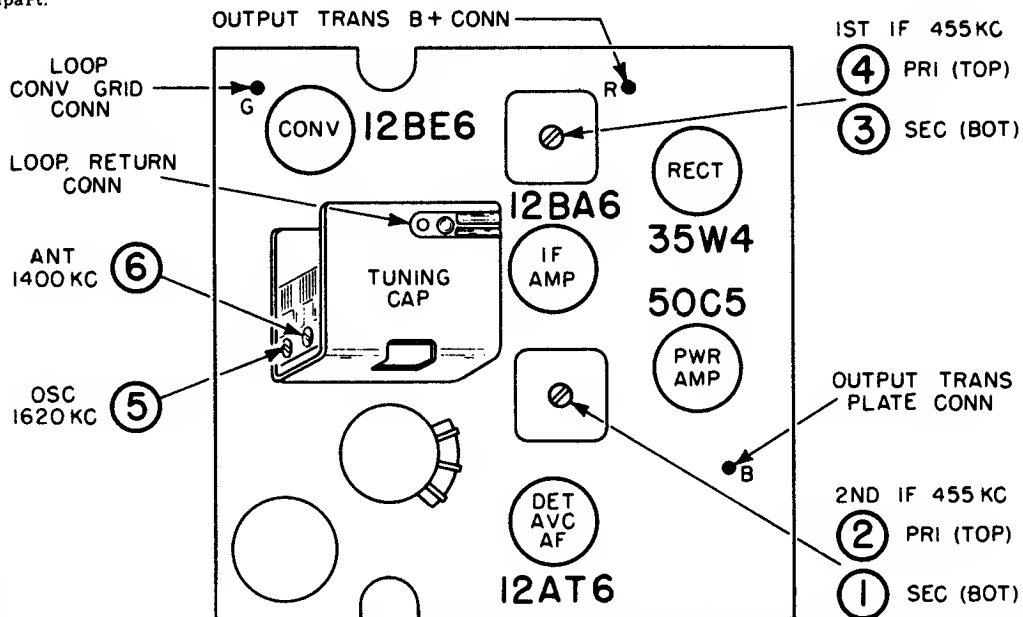

MANUAL OF 1954 MOST-OFTEN-NEEDED RADIO DIAGRAMS

MOTOROLA, INC.

MODEL
53D1

CHASSIS
HS-359

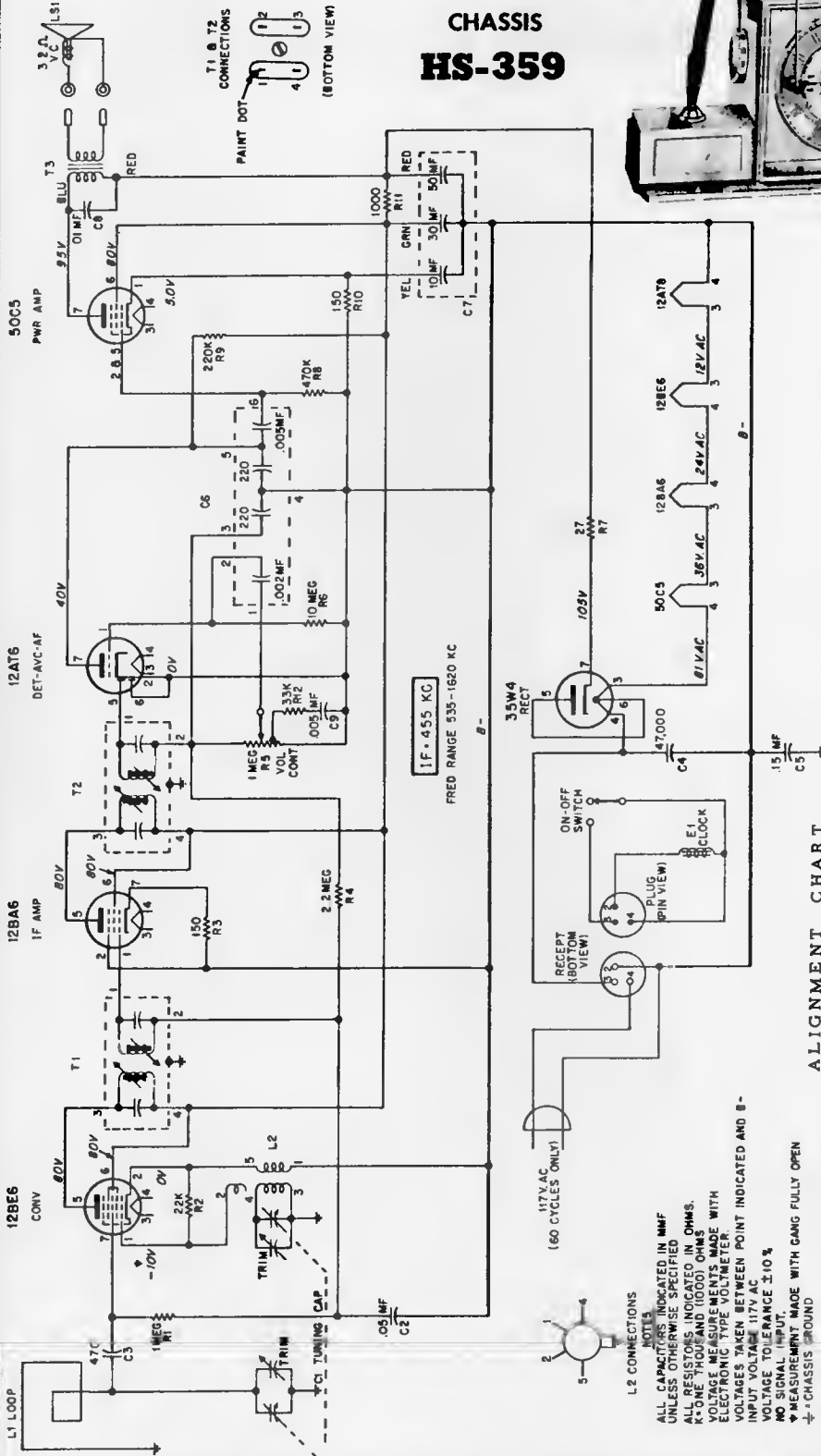
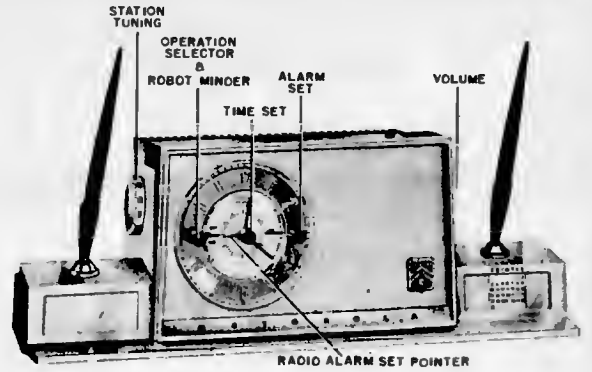

ALIGNMENT CHART

STEP	DUMMY ANTENNA	GENERATOR CONNECTION	GENERATOR FREQUENCY	GANG SETTING	ADJUST	REMARKS
IF ALIGNMENT						
1.	.1 mf	Grid of conv. (pin 7, 12BE6)	455 Kc	Fully open	1, 2, 3 & 4 (IF cores)	Adjust for maximum.
RF ALIGNMENT						
2.	.1 mf	Grid of conv. (pin 7, 12BE6)	1620 Kc	Fully open	5 (Osc)	Adjust for maximum.
3.	-	Radiation loop*	1400 Kc	Tune for max	6 (Ant)	Adjust for maximum.

*Connect generator output across 5" diameter, 5 turn loop and couple inductively to receiver loop. Keep loops at least 12" apart.

Motorola

MODELS

53C6

53C7

53C8

53C9

CHASSIS

HS-338

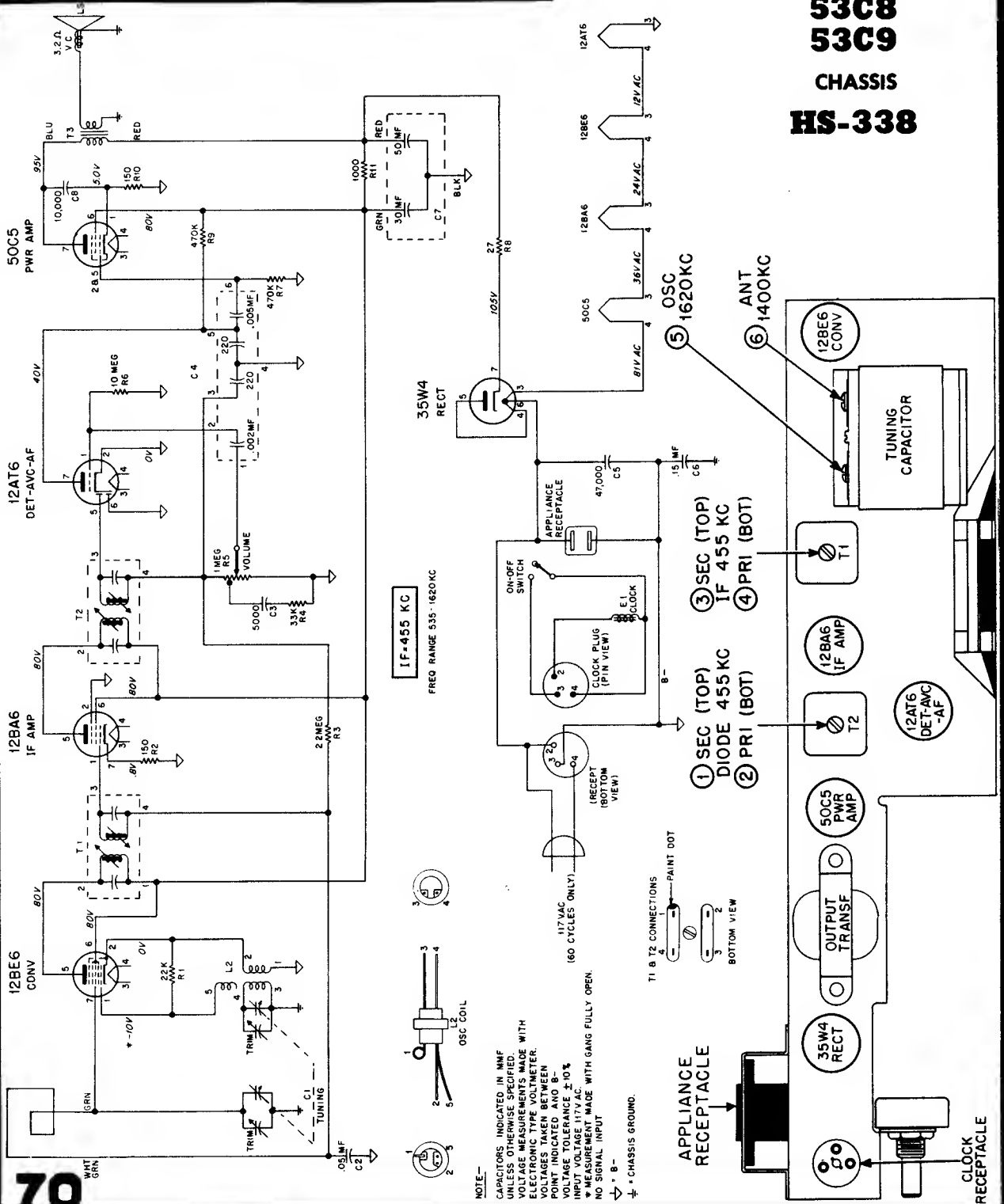

MANUAL OF 1954 MOST-OFTEN-NEEDED RADIO DIAGRAMS



MODELS

- | | |
|-------------|--------------|
| 53R1 | 53R1U |
| 53R2 | 53R2U |
| 53R3 | 53R3U |
| 53R4 | 53R4U |
| 53R5 | 53R5U |
| 53R6 | 53R6U |

CHASSIS

HS-384 HS-426

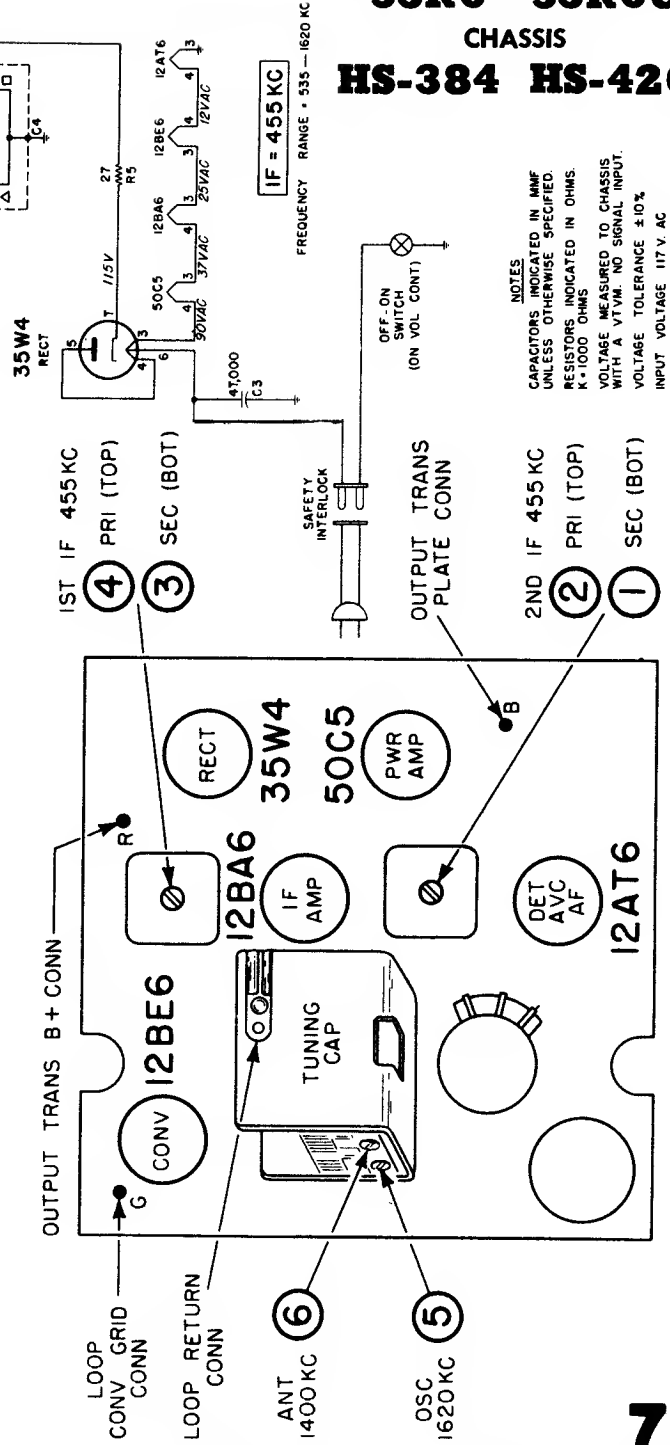
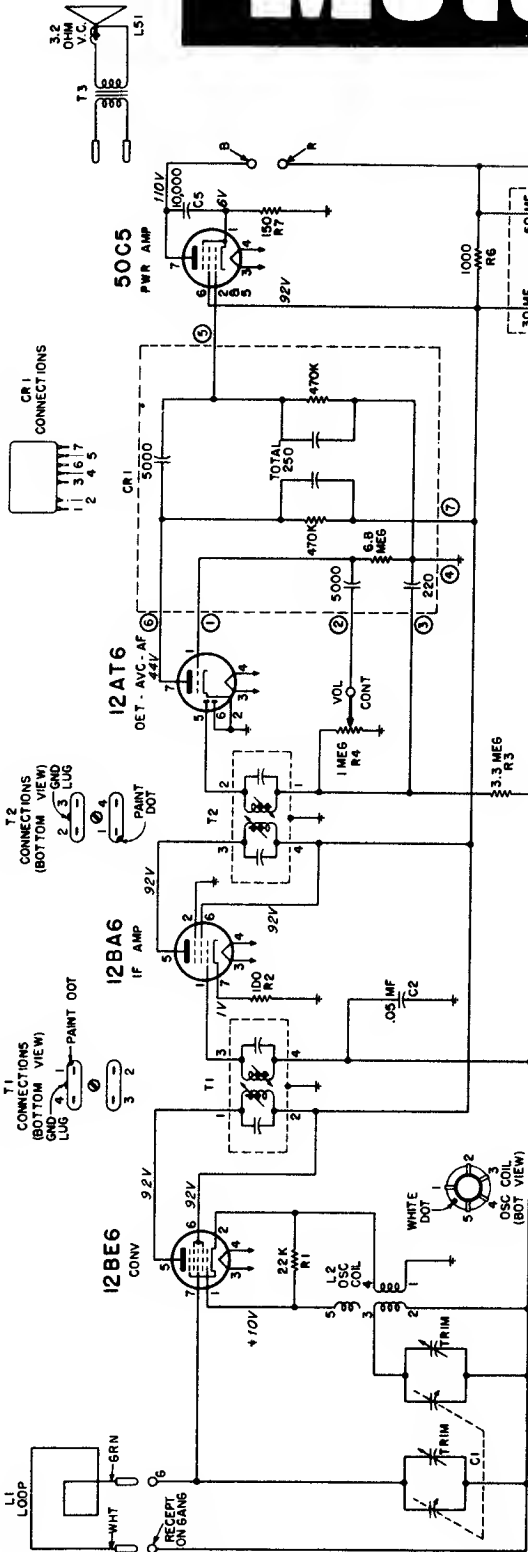

IF = 455 KC
FREQUENCY RANGE • 535 — 1620 KC

NOTES
CAPACITORS INDICATED IN MMF UNLESS OTHERWISE SPECIFIED.
RESISTORS INDICATED IN OHMS. K = 1000 OHMS
VOLTAGE MEASURED TO CHASSIS WITH A VTVM. NO SIGNAL INPUT.
VOLTAGE TOLERANCE ± 10%
INPUT VOLTAGE 117 V. AC
↑ WITH GANG FULLY OPEN

MANUAL OF 1954 MOST-OFTEN-NEEDED RADIO DIAGRAMS

MOTOROLA, INC.

CHASSIS
HS-336

MODELS
53X1
53X2
53X3
53X4

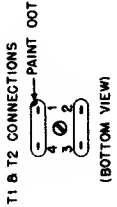
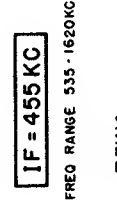
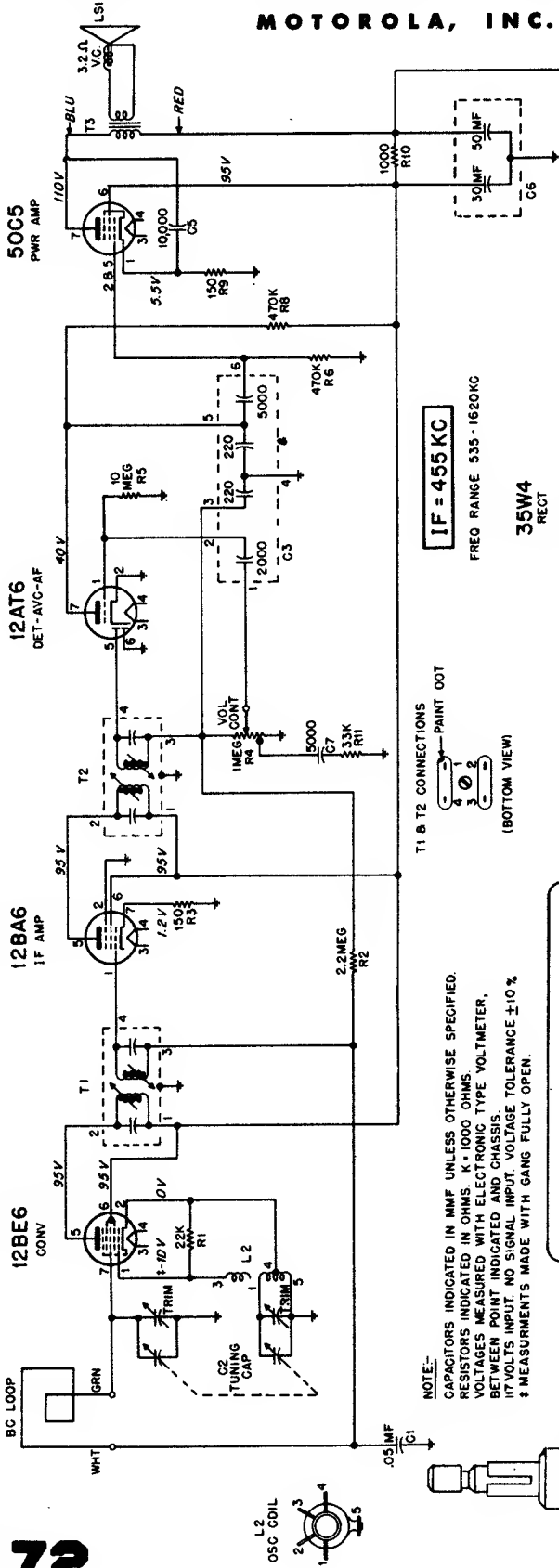

NOTE:-
CAPACITORS INDICATED IN MMF UNLESS OTHERWISE SPECIFIED.
RESISTORS INDICATED IN OHMS. K = 1000 OHMS.
VOLTAGES MEASURED WITH ELECTRONIC TYPE VOLTMETER,
BETWEEN POINT INDICATED AND CHASSIS.
117 VOLTS INPUT. NO SIGNAL INPUT. VOLTAGE TOLERANCE ±10 %
* MEASUREMENTS MADE WITH GANG FULLY OPEN.

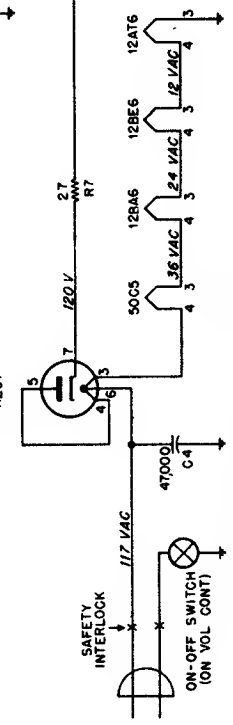

TO REMOVE CHASSIS FROM CABINET

1. Pull off the two radio control knobs and dial pointer knob.
2. Remove the four screws which hold the rear cover to the cabinet.
3. From the back of the cabinet, remove the four hex head screws which mount the radio chassis.
4. Unsolder the speaker leads.
5. Remove the screw that mounts the power interlock plug.
6. Remove the radio chassis from the cabinet.
7. Remove the four screws which mount the speaker and remove speaker from cabinet.

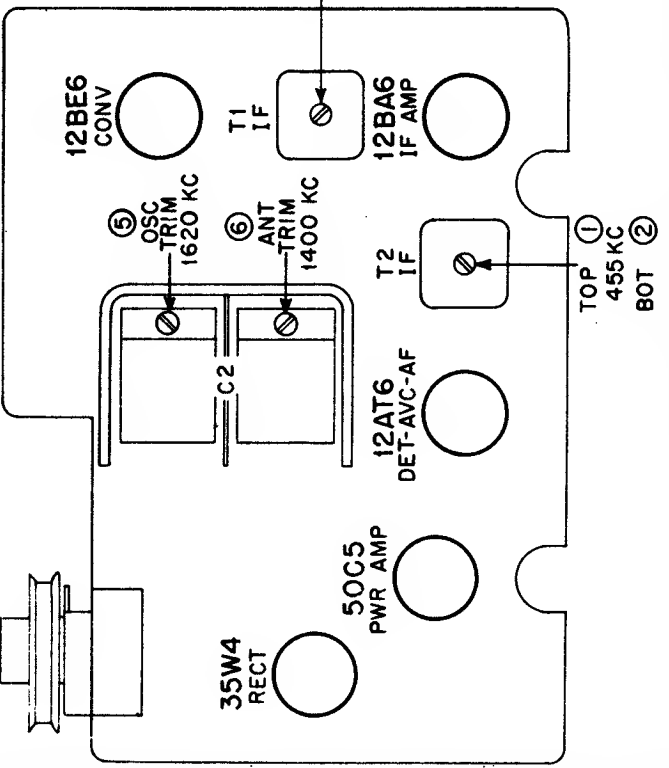

MANUAL OF 1954 MOST-OFTEN-NEEDED RADIO DIAGRAMS

MOTOROLA, INC.

CHASSIS
HS-397

MODELS
63C1
63C2
63C3

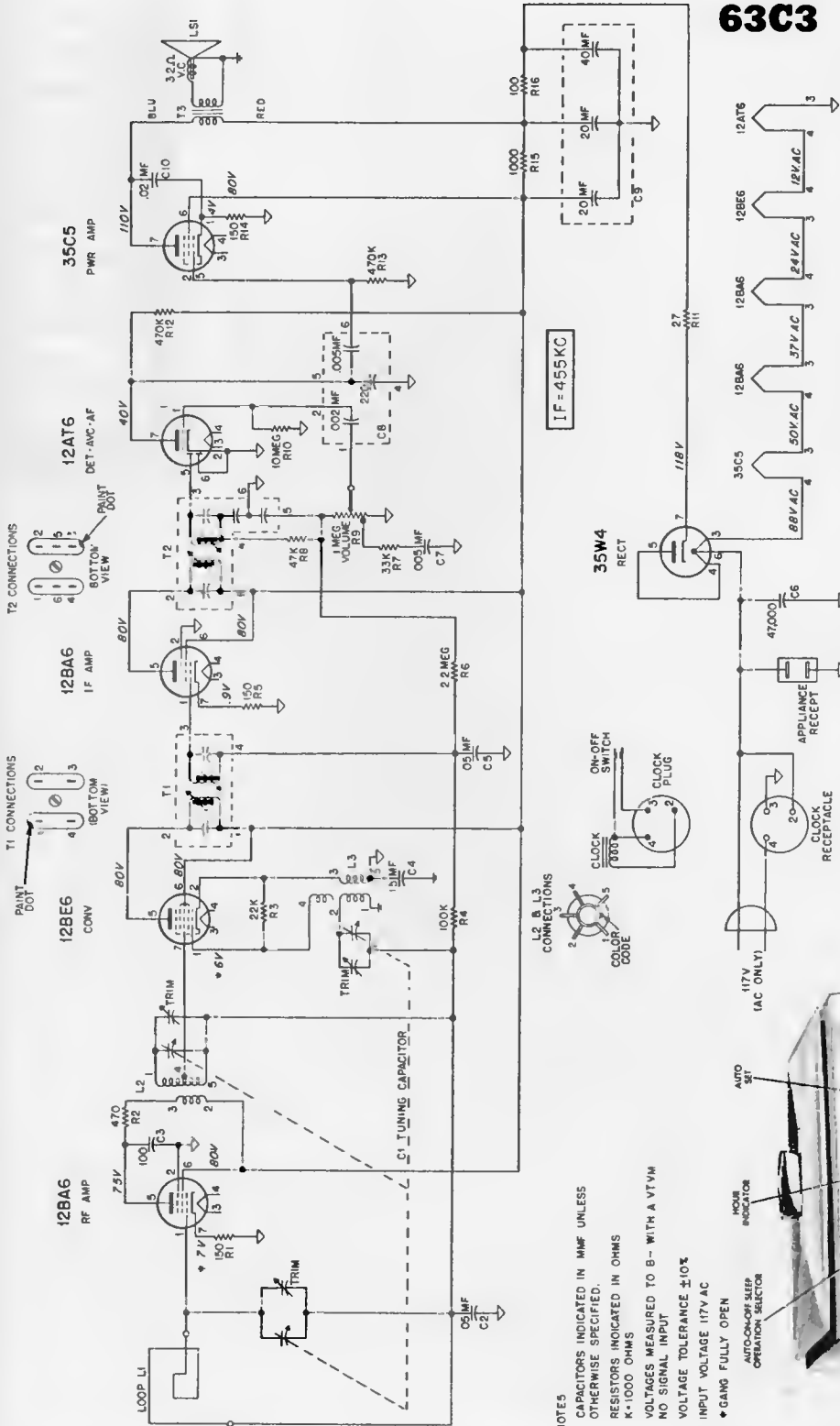

ALIGNMENT CHART

STEP	DUMMY ANTENNA	GENERATOR CONNECTION	GENERATOR FREQUENCY	GANG SETTING	ADJUST (See Fig. 1)	REMARKS
IF ALIGNMENT	.1 mf	Grid of conv. (pin 7, 12BE6)	455 Kc	Fully open	1, 2, 3 & 4 (IF cores)	Adjust for maximum.
			1620 Kc	Fully open	5 (Osc)	Adjust for maximum.
RF ALIGNMENT	.1 mf	Grid of conv. (pin 7, 12BE6)	1400 Kc	Tune for max	6 & 7 (RF & Ant trim)	Adjust for maximum.

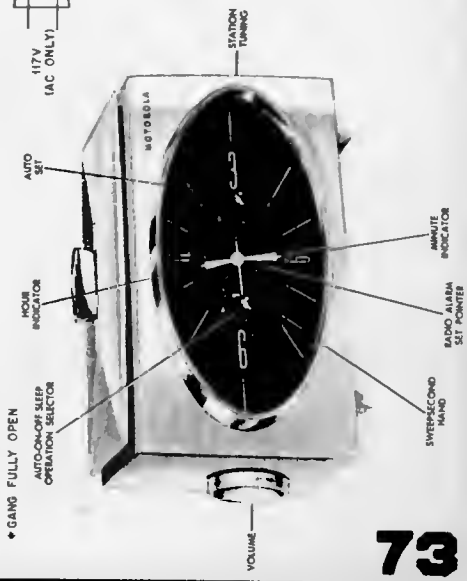

NOTES
CAPACITORS INDICATED IN MMF UNLESS OTHERWISE SPECIFIED.
RESISTORS INDICATED IN OHMS K=1000 OHMS
VOLTAGES MEASURED TO B - WITH A VTVM NO SIGNAL INPUT
VOLTAGE TOLERANCE $\pm 10\%$
INPUT VOLTAGE 117V AC
* GANG FULLY OPEN

MANUAL OF 1954 MOST-OFTEN-NEEDED RADIO DIAGRAMS

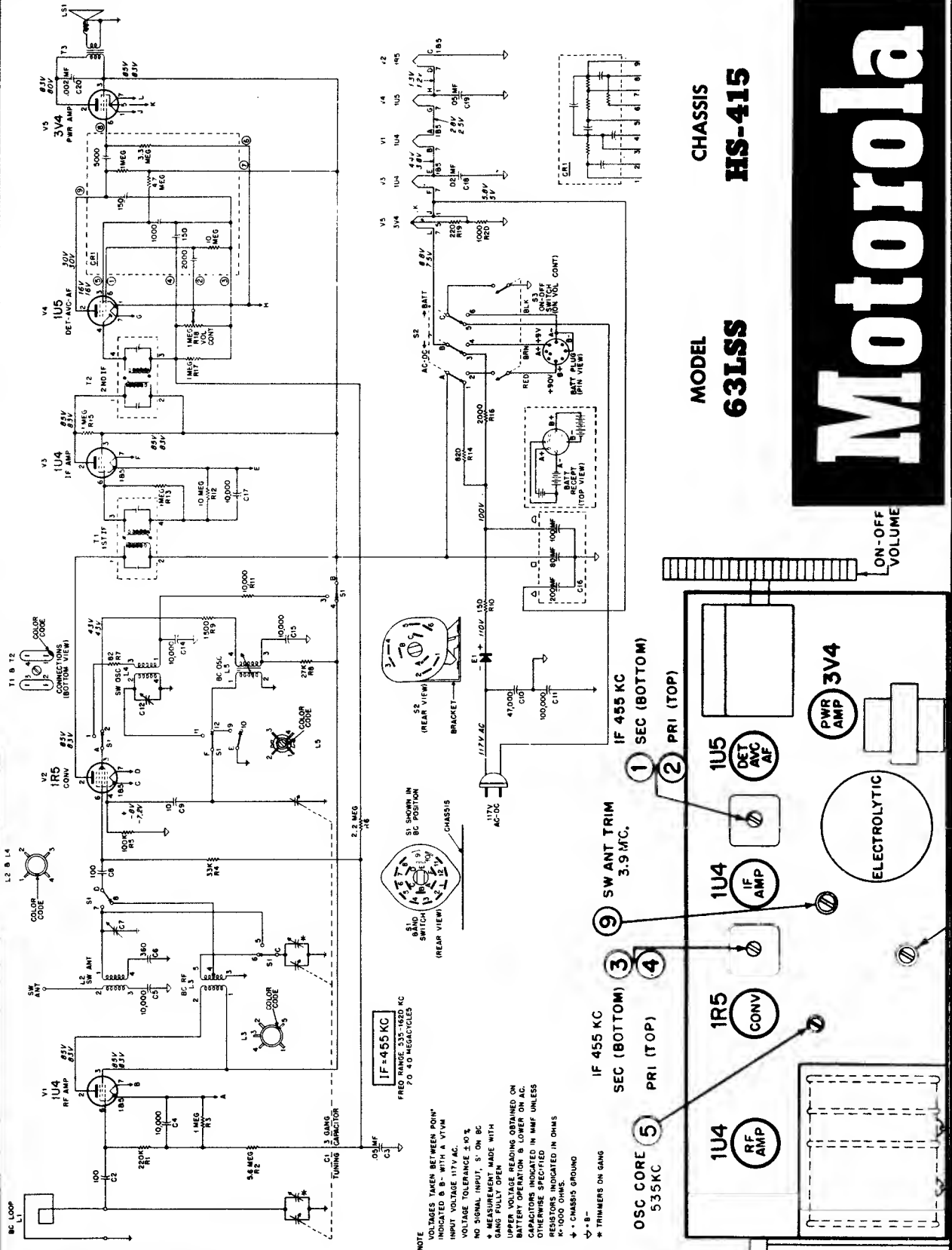

NOTE: VOLTAGES TAKEN BETWEEN POINTS INDICATED BY * WITH A VTVM INPUT VOLTAGE 157V AC, 10% NO SIGNAL INPUT, S' ON BC GANG FULLY OPEN * MEASUREMENT MADE WITH UPPER VOLTAGE READING OBTAINED ON BATTERY OPERATION & LOWER ON AC. CAPACITORS INDICATED IN MUF UNLESS OTHERWISE SPECIFIED * RESISTORS INDICATED IN OHMS * - CHASSIS GROUND

↔ - B - TRIMMERS ON GANG

MANUAL OF 1954 MOST-OFTEN-NEEDED RADIO DIAGRAMS

MOTOROLA, INC.

MODELS

63X1
63X1A
63X2
63X3

CHASSIS

HS-335

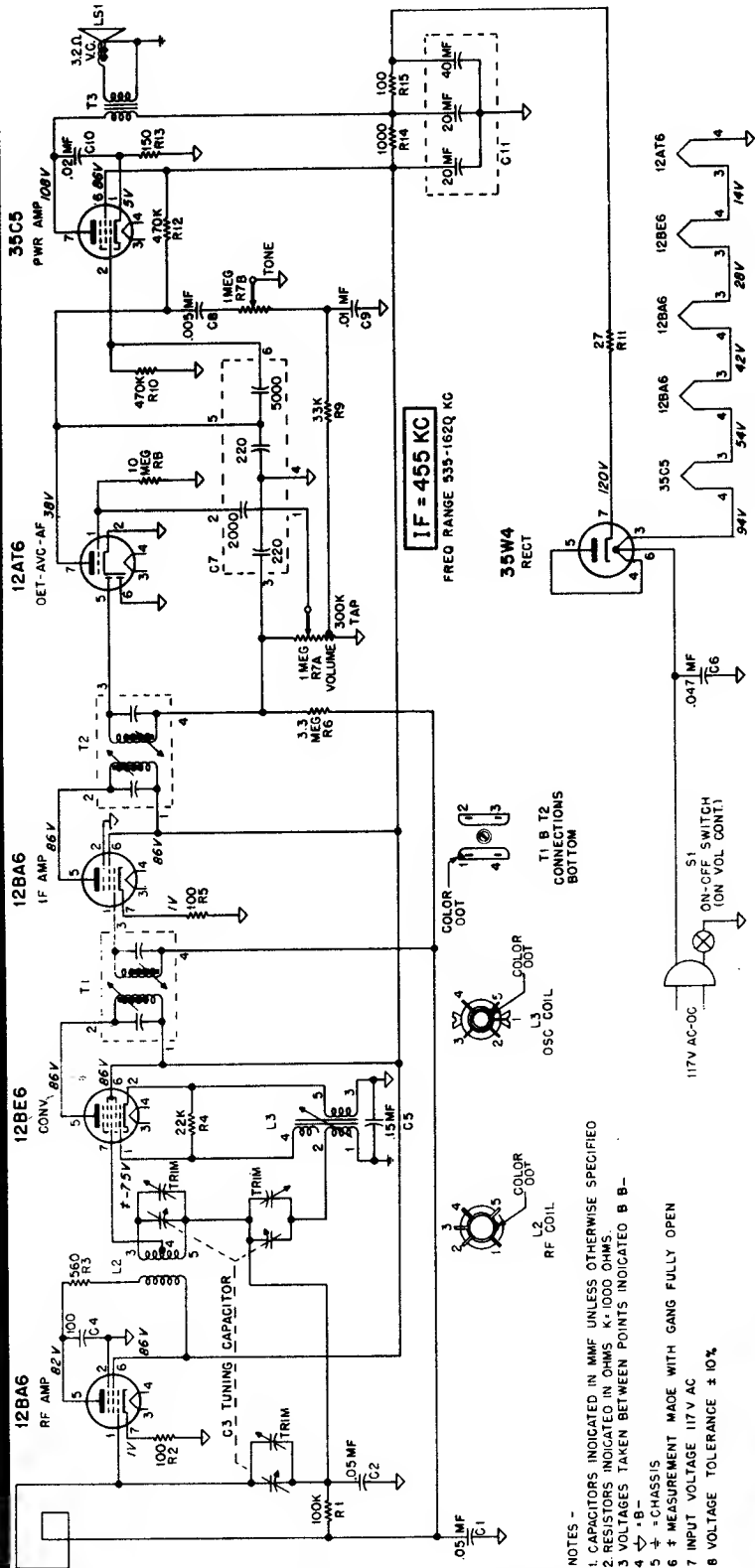

- NOTES -
1. CAPACITORS INDICATED IN MMF UNLESS OTHERWISE SPECIFIED
 2. RESISTORS INDICATED IN OHMS, K=1000 OHMS.
 3. VOLTAGES TAKEN BETWEEN POINTS INDICATED B-B.
 4. ∇ - B-
 5. ∇ - CHASSIS
 6. * MEASUREMENT MADE WITH GANG FULLY OPEN
 7. INPUT VOLTAGE 117V AC
 8. VOLTAGE TOLERANCE $\pm 10\%$

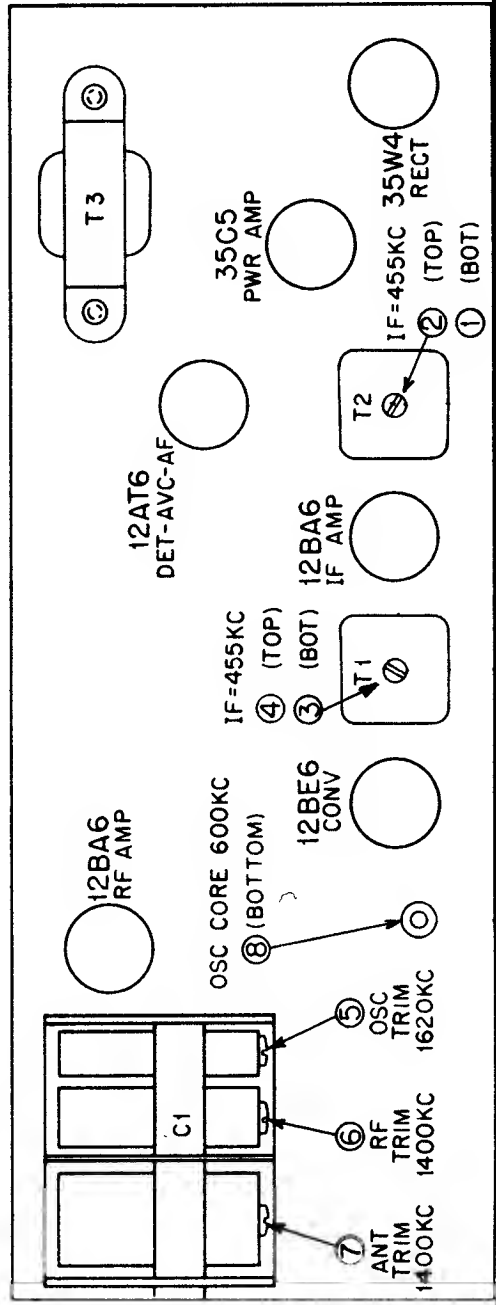

MANUAL OF 1954 MOST-OFTEN-NEEDED RADIO DIAGRAMS

MOTOROLA, INC.

MODEL
404

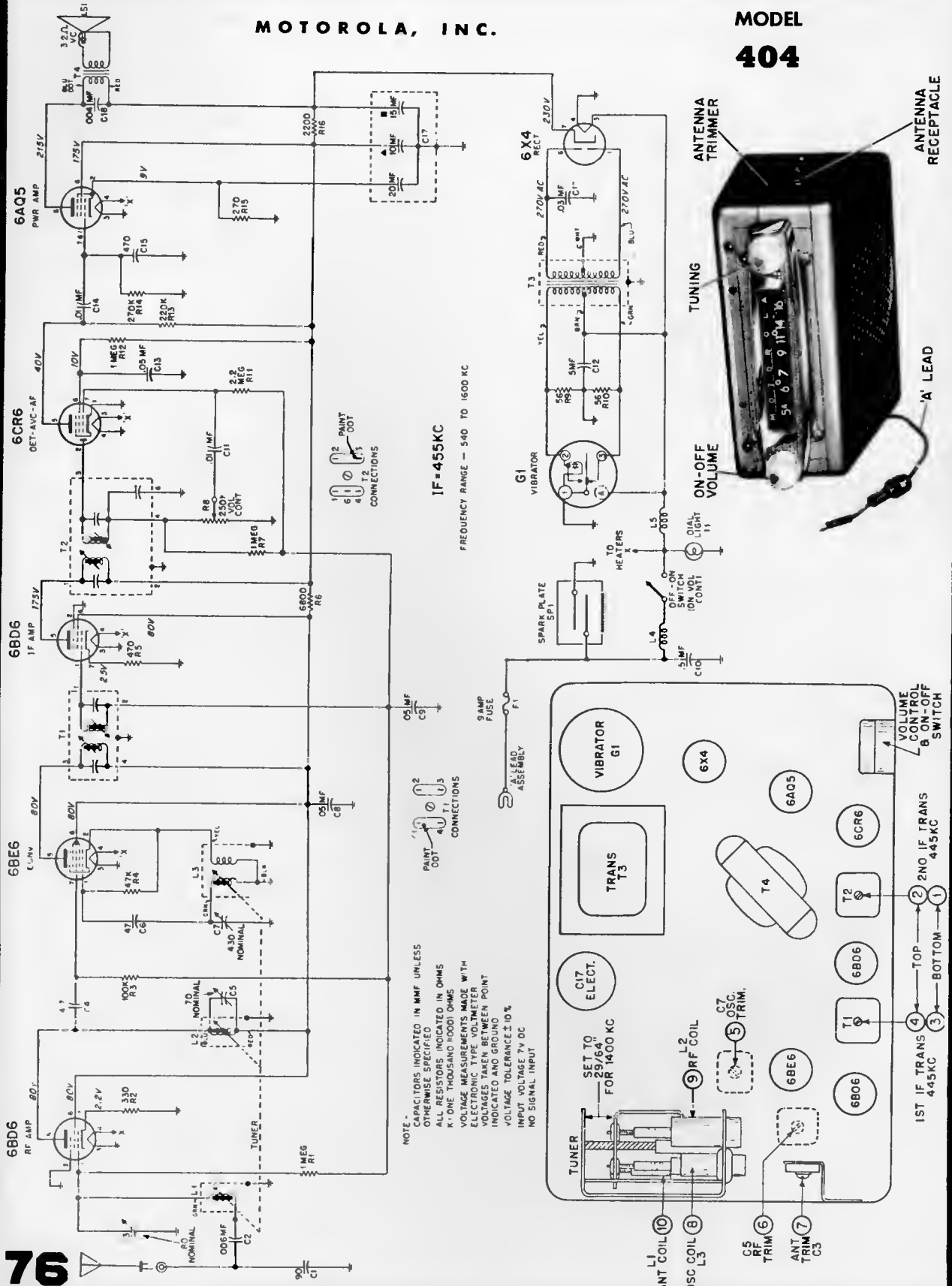

76

Motorola

MODEL
504

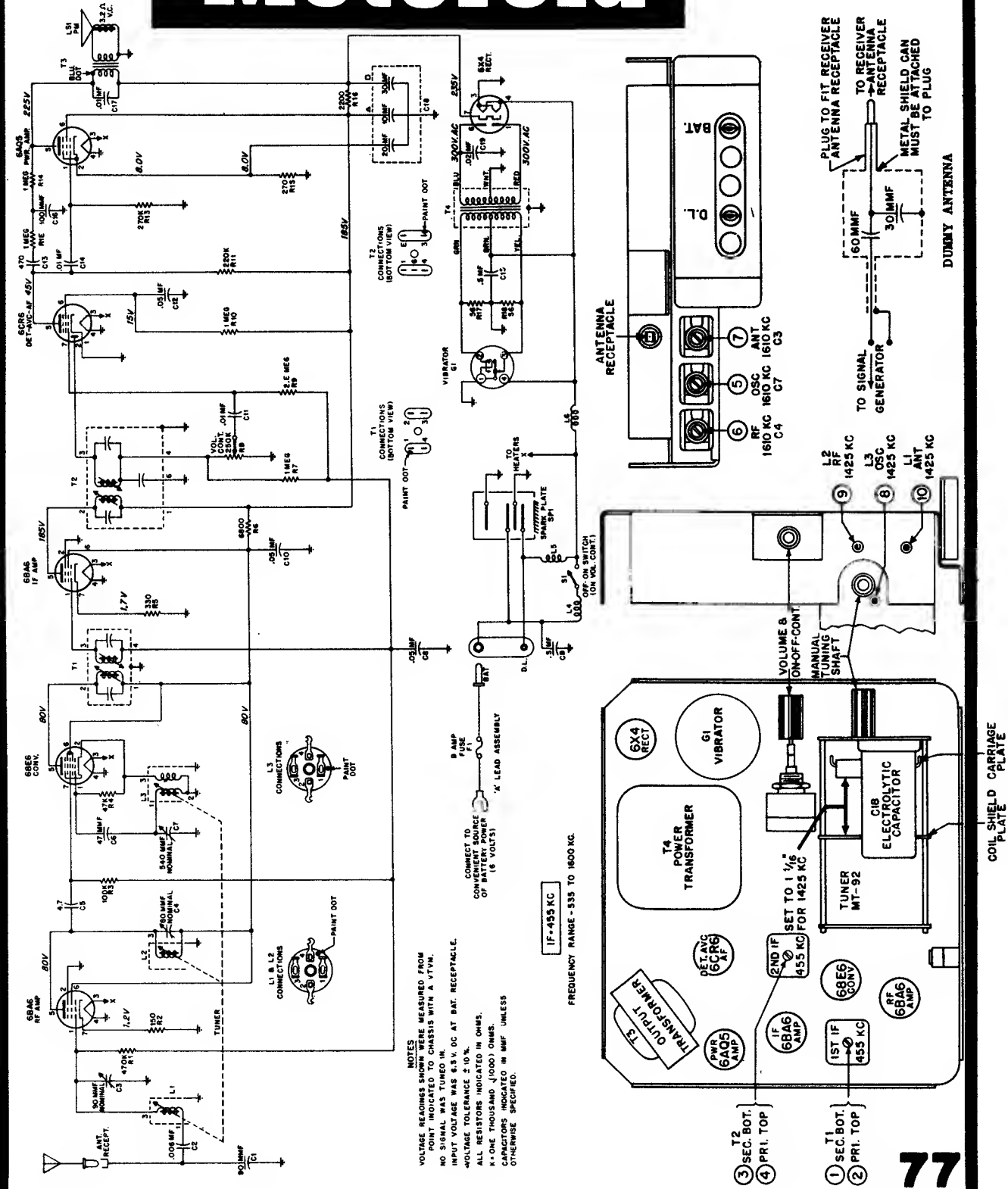

MANUAL OF 1954 MOST-OFTEN-NEEDED RADIO DIAGRAMS

MOTOROLA, INC.

TYPE - Two-piece automotive type receiver, specifically designed for installation in Dodge D50, D51, D52, and D53 cars.

MOPAR

MODEL

612

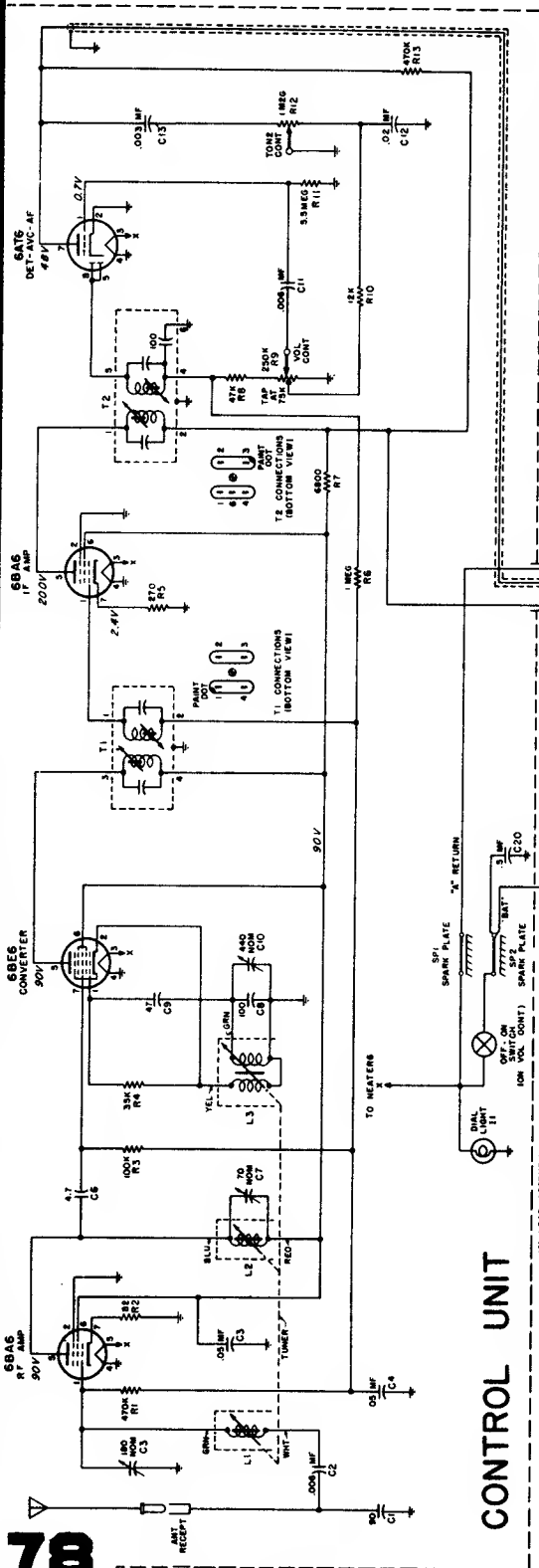

IF = 455 KC

FREQUENCY RANGE 540 TO 1600 KC

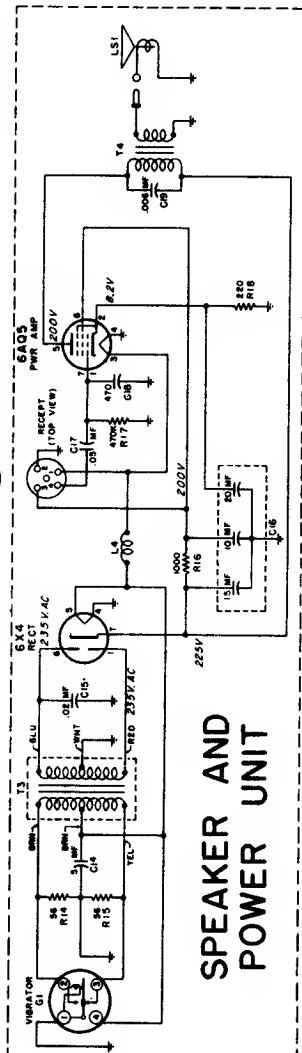

SPEAKER AND POWER UNIT

TO SET PUSHBUTTONS

1. Turn volume up until stations can be heard.
2. Pull out station selector button to unlock tuner and, with the manual tuning knob, tune to the station desired.
3. Push button in to lock tuner. This station is now set for automatic tuning.
4. Follow the same procedure for the remaining push-buttons.

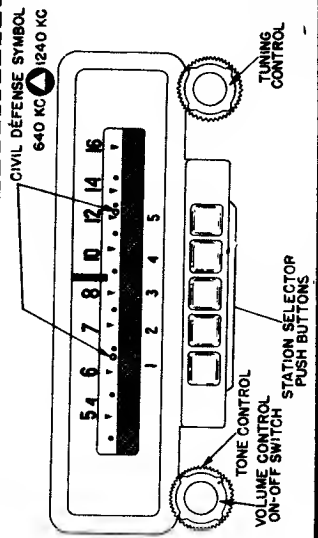

NOTES
 RESISTORS INDICATED IN OHMS
 K = ONE THOUSAND (1000) OHMS
 CAPACITORS INDICATED IN MICROGRAMMADS UNLESS OTHERWISE SPECIFIED
 VOLTAGE READINGS SHOWN WERE TAKEN FROM POINT INDICATED TO CHASSIS WITH A VTVM
 INPUT VOLTAGE 6.3V DC AT ON-OFF SWITCH.
 VOLTAGE TOLERANCE ±10%.

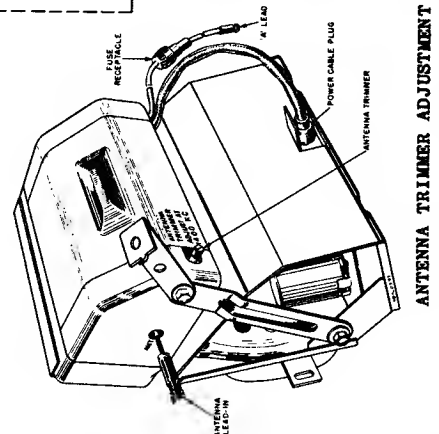

MANUAL OF 1954 MOST-OFTEN-NEEDED RADIO DIAGRAMS

MOTOROLA, INC.

(Alignment information on Model 829 is on the next page)

MOPAR

MODEL

829

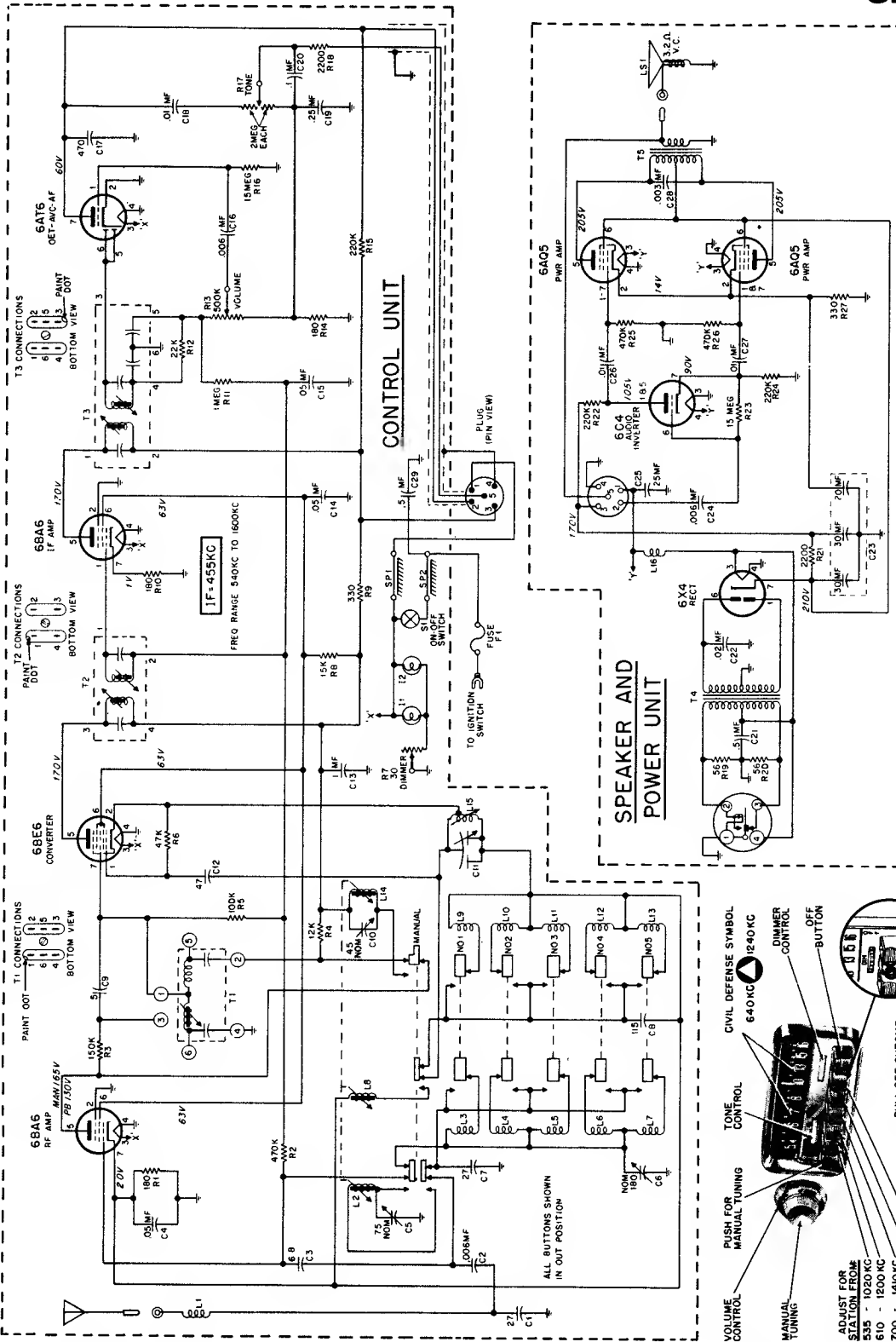

NOTES:
 RESISTOR INDICATED IN OHMS.
 CAPACITOR INDICATED IN MICROFARADS UNLESS OTHERWISE SPECIFIED.
 VOLTAGES TAKEN FROM POINT INDICATED UNLESS NOTED OTHERWISE.
 NO SIGNAL INPUT.
 INPUT VOLTAGE 6.3 V. AC.
 VOLTAGE TOLERANCE $\pm 10\%$.

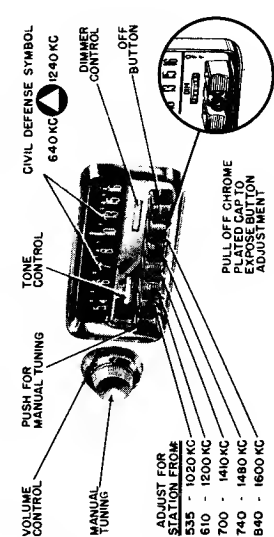

(See the next page, over, for alignment and other service data.)

MANUAL OF 1954 MOST-OFTEN-NEEDED RADIO DIAGRAMS

MOTOROLA, INC.

(See preceding page for circuit diagram of Model 829.)

MOPAR

**MODEL
829**

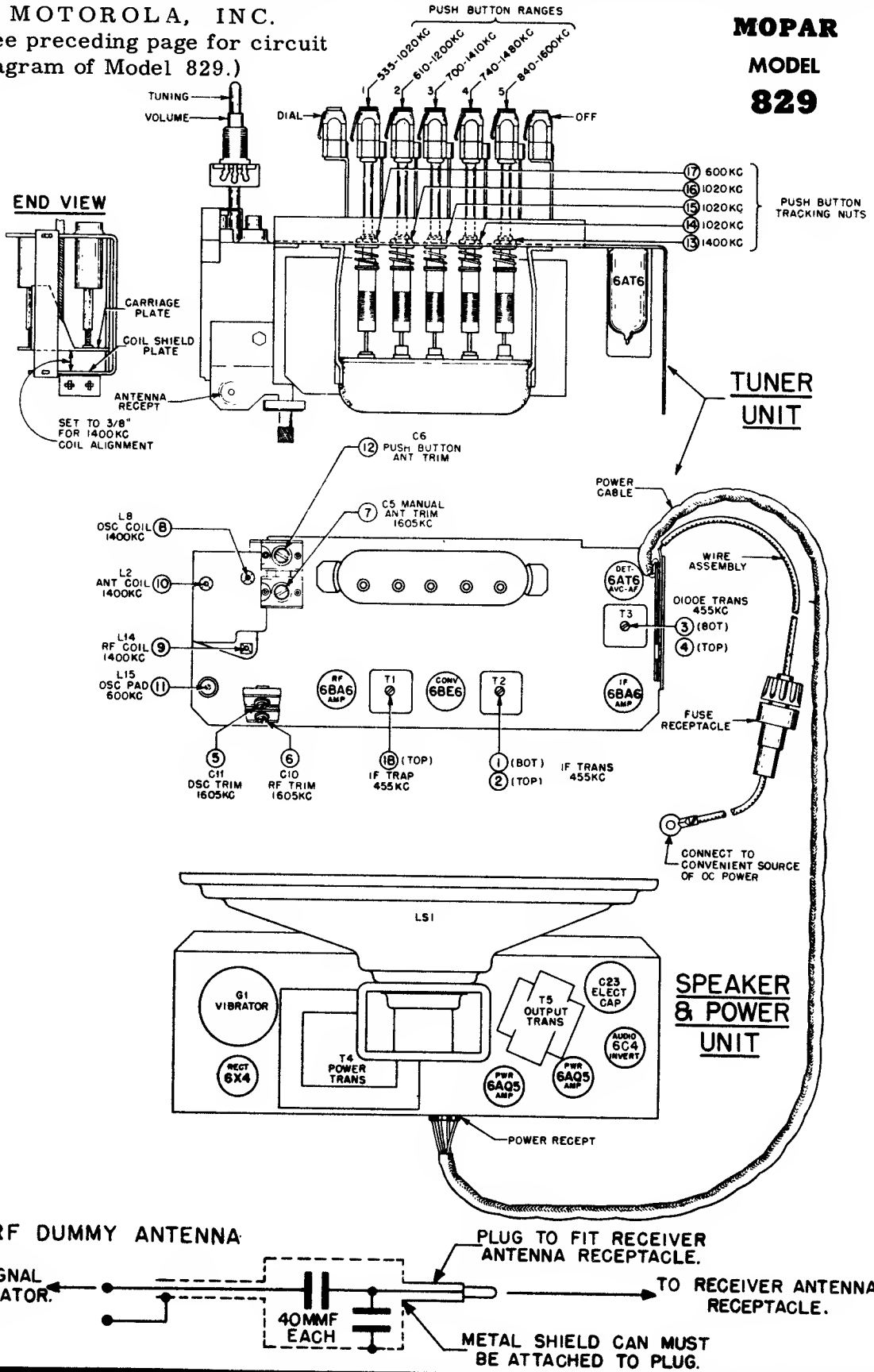

MANUAL OF 1954 MOST-OFTEN-NEEDED OLYMPIC RADIO MODEL NUMBER 445

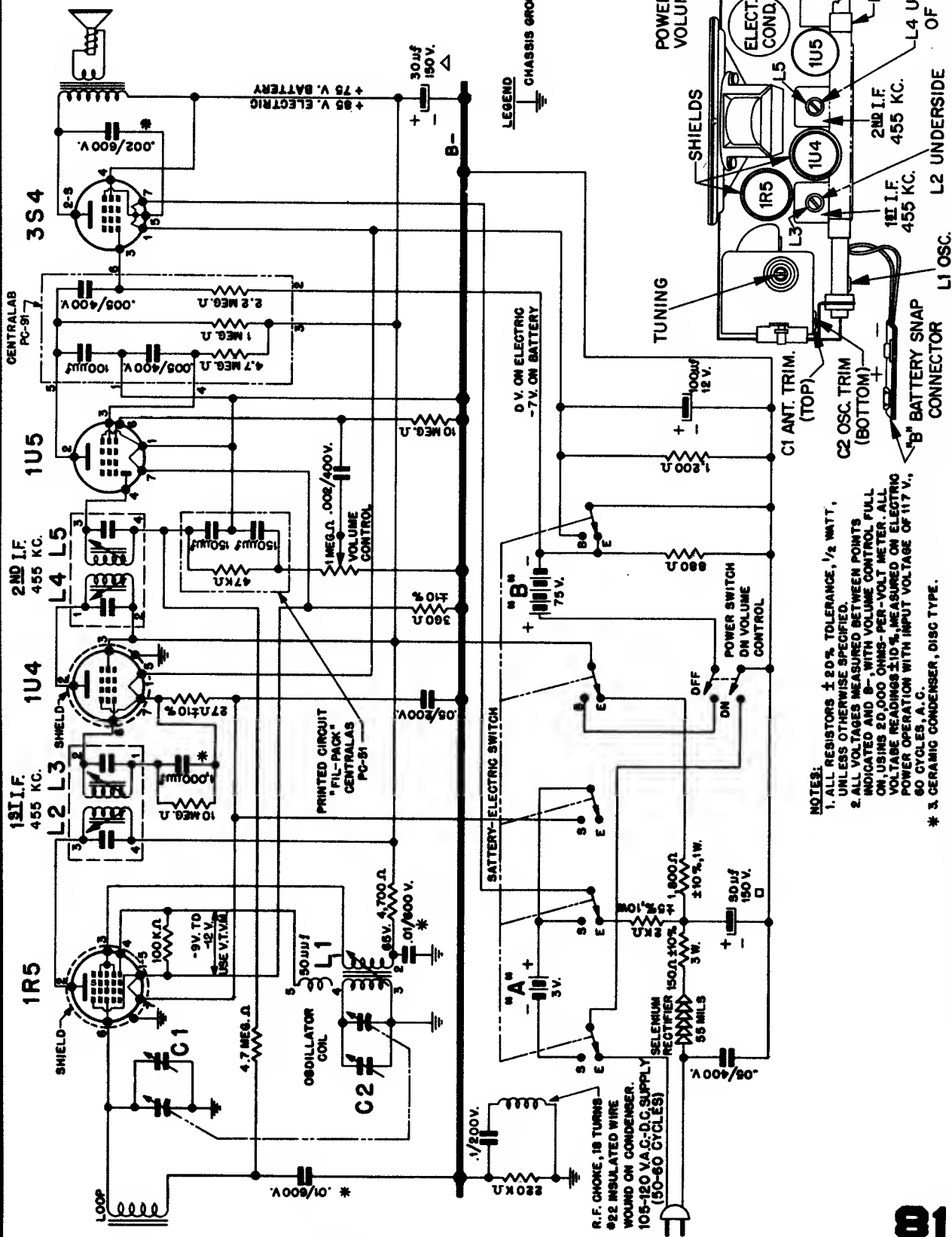

NOTES:

1. ALL RESISTORS ±20% TOLERANCE, 1/2 WATT, UNLESS OTHERWISE SPECIFIED.
2. ALL VOLTAGES MEASURED BETWEEN POINTS INDICATED AND B-, WITH VOLUME CONTROL FULL ON. USES 20,000 OHMS-PER-VOLT METER. ALL VOLTAGE READINGS ±10%, MEASURED ON ELECTRIC POWER OPERATION WITH INPUT VOLTAGE OF 117 V., 60 CYCLES, A.C.
- * 3. CERAMIC CONDENSER, DISC TYPE.

MANUAL OF 1954 MOST-OFTEN-NEEDED RADIO DIAGRAMS

OLYMPIC RADIO & TELEVISION INC.

MODEL 449

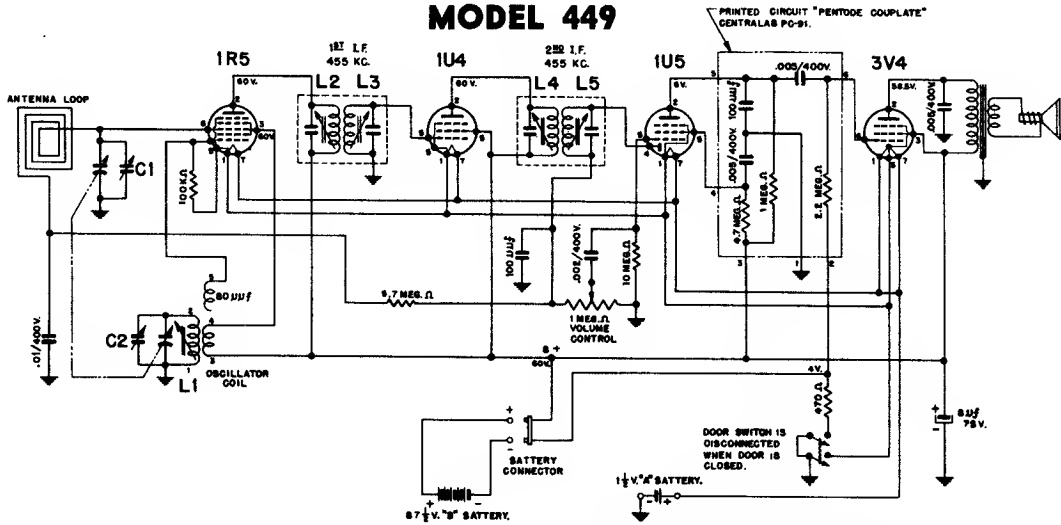

- NOTES:**
1. ALL RESISTORS ± 20% TOLERANCE, 1/2 WATT, UNLESS OTHERWISE SPECIFIED.
 2. ALL MICA CONDENSERS ± 20% TOLERANCE UNLESS OTHERWISE SPECIFIED.
 3. ALL VOLTAGES MEASURED BETWEEN POINTS INDICATED AND CHASSIS GROUND, WITH VOLUME CONTROL FULL ON, USING 20,000 OHMS-PER-VOLT METER. ALL VOLTAGE READINGS ± 10%, MEASURED WITH BATTERY VOLTAGES SHOWN.

BATTERIES: 1 - 1 1/2 v Eveready D-99 or 950, Burgess 2R or Ray-O-Vac 2UP or RCA VS036 or equivalent.
 1 - 67 1/2 v Eveready #467, or Burgess XX45 or RCA VSO16 or equivalent.

TUBE AND BATTERY LAYOUT

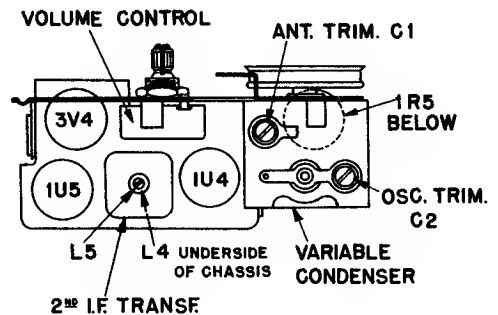
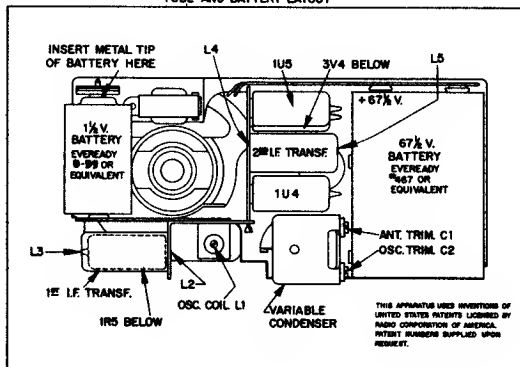

ALIGNMENT PROCEDURE CHART

STEP	CONNECT HIGH SIDE OF SIGNAL GENERATOR TO-	SET SIGNAL GENERATOR TO-	SET POINTER TO-	ADJUST THE FOLLOWING FOR MAXIMUM OUTPUT. (KEEP SIGNAL FROM SIGNAL GENERATOR AS LOW AS POSSIBLE.)
1	R. F. SECTION OF VARIABLE CONDENSER IN SERIES WITH A .1 MFD. 400 VOLT CONDENSER.	455 KC.	EXTREME RIGHT HAND POSITION (CONDENSER PLATES FULLY OPEN)	L5, L4, L3, L2 AND REPEAT IN SAME ORDER (1st. AND 2nd. I.F. TRANSFORMERS.)
2	USE RADIATED SIGNAL	1600 KC.	1600 KC. (16 ON DIAL)	C2 (OSCILLATOR TRIMMER)
3	(CONNECT BOTH SIDES OF SIGNAL GENERATOR TO RADIATION LOOP)	1300 KC.	MAXIMUM SIGNAL (APPROX. 13 ON DIAL)	C1 (ANTENNA TRIMMER)
4		600 KC.	MAXIMUM SIGNAL (APPROX. 6 ON DIAL)	ADJUST L1 ROCK VARIABLE FOR MAXIMUM SIGNAL.
5	REPEAT STEPS 2, 3 & 4 AT LEAST TWICE TO INSURE MAXIMUM SENSITIVITY & PROPER DIAL TRACKING.			

MANUAL OF 1954 MOST-OFTEN-NEEDED RADIO DIAGRAMS

Packard-Bell

Models 531, 532, and 533

SPECIAL SERVICING INFORMATION:

DC RESISTANCE MEASUREMENTS:

1st I-F Coil:

- Primary, 12 ohms
- Secondary, 13 ohms

2nd I-F Coil:

- Primary, 13 ohms
- Secondary, 13 ohms

Oscillator Coil:

- Primary, 1 ohm
- Secondary, 5.5 ohms

Loop Antenna:

- Resistance, 1 ohm

OSCILLATOR CATHODE VOLTAGES:

(Measured using AC vacuum tube voltmeter with an input impedance of more than 10 megohms. Line voltage 117 volts AC.)

- 1500 Kc. 2.6 volts AC (rms)
- 1000 Kc. 2.3 volts AC
- 750 Kc. 2.1 volts
- 540 Kc. 2.0 volts

ALIGNMENT PROCEDURE:

The alignment of the set is accomplished by following the steps in the chart below. Connect output meter to speaker voice coil. Use isolation transformer, if available, for shack protection.

Each adjustment should be made using a minimum input signal. Connect test oscillator through a .01 mfd capacitor to the point indicated below. Ground lead of oscillator is connected to B minus bus.

STEP	CONNECT TEST OSCILLATOR TO	TEST OSCILLATOR FREQUENCY	RADIO DIAL SETTING	ADJUST
1.	Pin 1, V-1 (12BE6)	455 Kc.	540 Kc.	S-1, S-2, S-3, & S-4 for MAX.
2.	Antenna Clip	1620 Kc.	1620 Kc.	S-5 for MAX.
3.	Antenna Clip	1500 Kc.	Tune to Osc. Signal	S-6 for MAX.

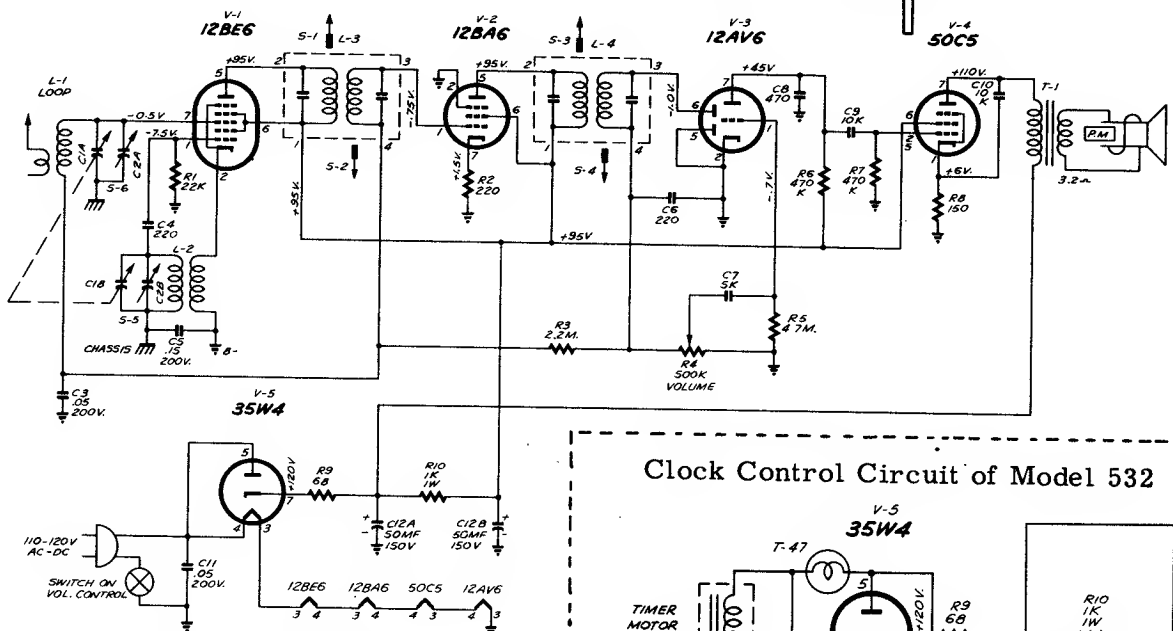
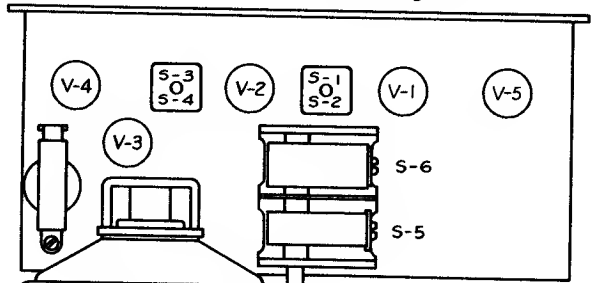

Socket voltages measured as follows:

1. Line voltage, 117 volts AC.
2. Volume control at maximum.
3. VTVM between socket terminal and B minus bus.
4. Only DC voltages measured. Allow 10% tolerance.

Clock Control Circuit of Model 532

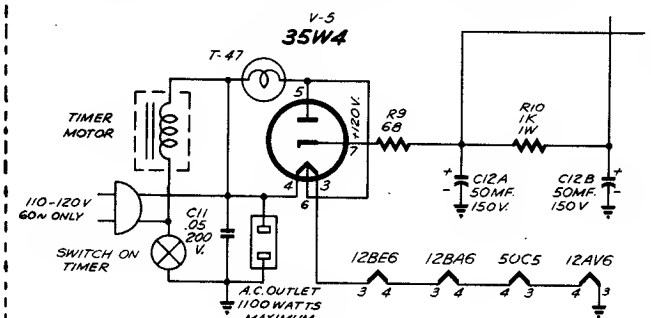

MANUAL OF 1954 MOST-OFTEN-NEEDED RADIO DIAGRAMS

Packard-Bell

MODEL 631 RADIO

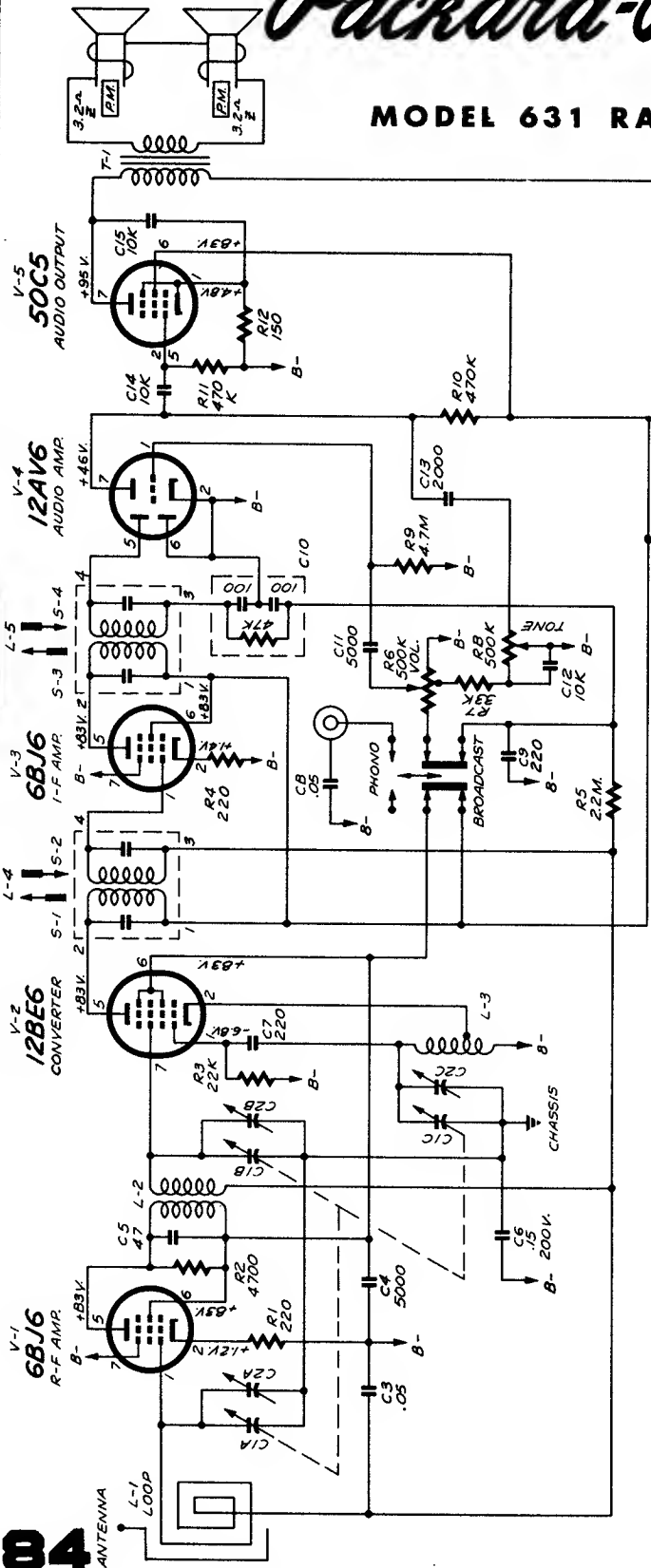

ALIGNMENT PROCEDURE:

STEP	CONNECT TEST OSCILLATOR TO	OSCILLATOR FREQUENCY	RADIO DIAL SETTING	ADJUST
1.	Pin 7, V-2	455 Kc.	540 Kc. S-1, S-2, S-3 & S-4 for MAX	
2.	Antenna Clip	1620 Kc.	1620 Kc. C2C for MAX	
3.	Antenna Clip	1500 Kc.	Tune to C2A & C2B Osc. Signal for MAX	

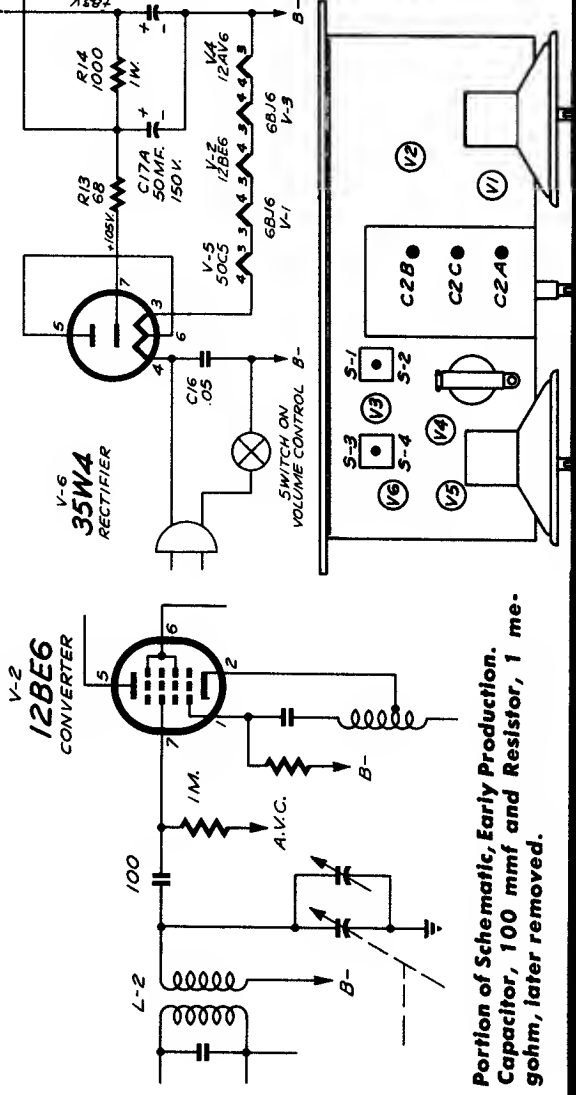

Portion of Schematic, Early Production. Capacitor, 100 mmf and Resistor, 1 megohm, later removed.

MANUAL OF 1954 MOST-OFTEN-NEEDED RADIO DIAGRAMS

SERVICE HINTS ON PHILCO PRINTED CIRCUITS

Although these hints are exact for Model B570, Code 122, they are applicable to other Philco sets using printed circuits.

REMOVING THE CHASSIS FROM THE CABINET

To remove the chassis from the cabinet, first remove the station selector knob, volume control knob, and, at the bottom-center of the dial scale, remove the dial scale retaining screw. A flat object (knife blade) placed under the bottom edge will assist in prying the scale out of the cabinet. Pull to remove the pointer from the tuning gang shaft. Remove the screws from the cabinet back, and pull the back away from the back of the cabinet (use care to prevent breaking the leads from the loop aerial) far enough to reach in and remove the pilot lamp and socket from the retaining clip. Unsolder the output transformer leads from the speaker. Then remove the chassis mounting screws from beneath the cabinet, and remove the chassis.

After removing the chassis from the cabinet remove the subbase, using the following procedure.

1. Remove the output transformer and dial light connections by pulling the jacks from the pins on the subbase.
2. Unsolder the volume control and a-c switch leads, and unsolder and remove the loop aerial.
3. At the rear of the panel, bend the hold down tabs out flush with the subbase, and remove.

PARTS REPLACEMENT

Whenever possible, replace all components and leads from the top side of the chassis. In cases where this is not possible, the components must be unsoldered when removed from the bottom. Use only a light-weight low-wattage iron of approximately 22.5 to 25 watts, and always use a low-melting-point solder. Extreme caution must be used to prevent solder from dropping or splashing, and to avoid lifting of the printed wiring foil. Use only the tip of the soldering iron at the solder point whenever heat is being applied. Hold the subbase in one hand while applying heat to the solder point and throw the solder off, with a downward thrust, as soon as it starts to melt. When the solder is removed, the part to be repaired or replaced can be lifted from its located. Insert the new part and secure it with just a drop of solder at each point.

To replace tube sockets and i-f transformers, follow the procedure given above for removing solder. Then use a sharp knife to sever the remaining thin bond of solder at the connections. With the solder removed, the part can be backed out of the slots. Before inserting the repaired or new part, clean all connections at the unsoldered lugs. Use caution when reinserting parts through the subbase slots, so that the foil is not lifted. When soldering is complete apply an electrical varnish to all repaired areas.

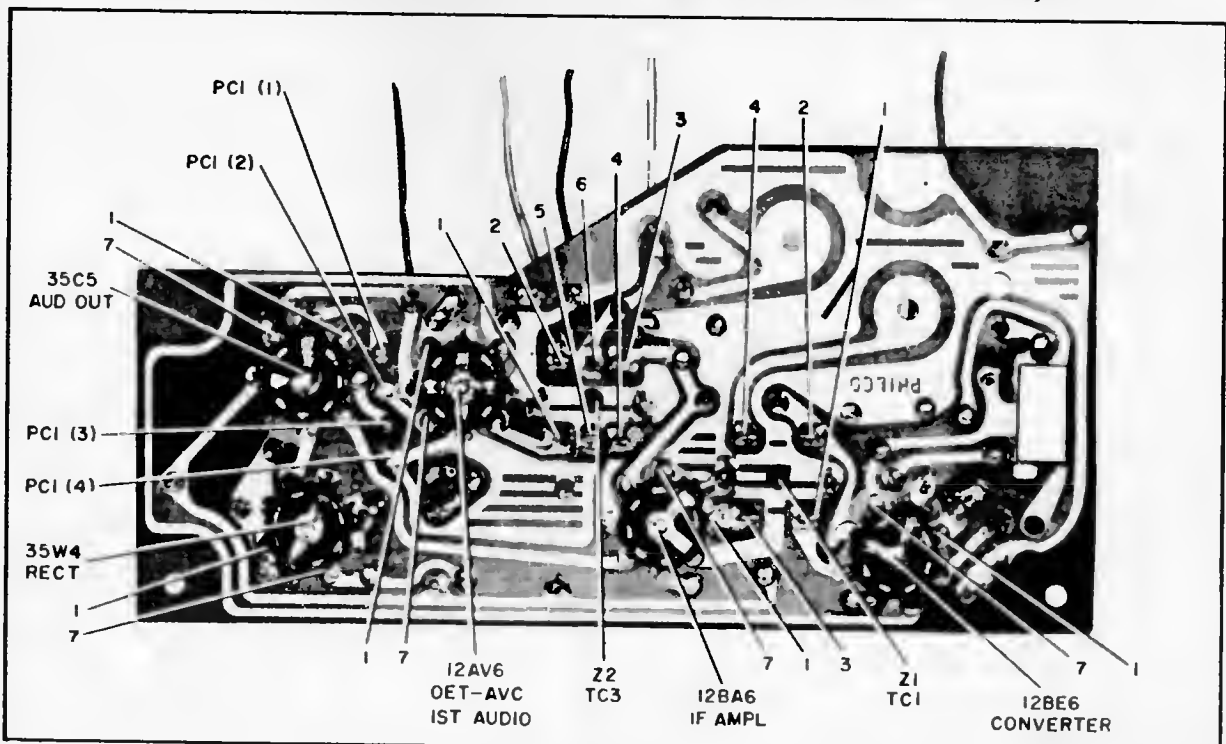

Base View, Showing Printed Wiring Circuit

MANUAL OF 1954 MOST-OFTEN-NEEDED RADIO DIAGRAMS

PHILCO HOME RADIO MODEL B570, Code 121

This data is exact for Model B570, Code 121, and is reproduced through the courtesy of the Philco Corp. Model B572, Code 121, is identical. Model B569, Code 121, is very similar. Models B570, Code 122, and B572, Code 122, are also similar, but use printed circuits. See the preceding page for service data on Philco printed circuits. Clock-type B710 and B711 (Code 121) and B712X (Code 122) are similar to these models in the main respect.

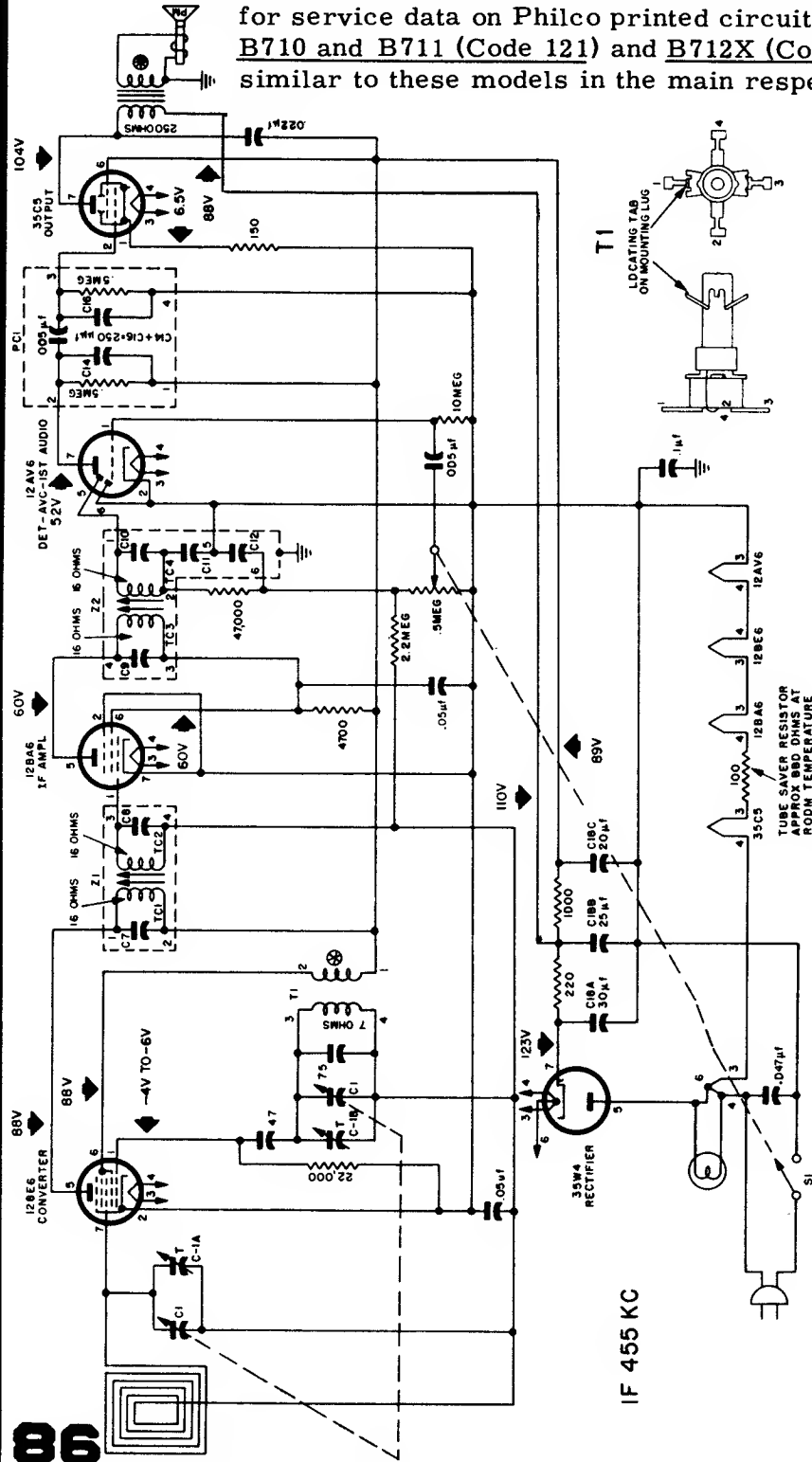

ALIGNMENT CHART

STEP	SIGNAL GENERATOR		RADIO		ADJUST
	CONNECTION TO RADIO	DIAL SETTING	DIAL SETTING	SPECIAL INSTRUCTIONS	
1	Ground lead to B-; output lead through a .1-μf. condenser to grid (pin 7) of 12BE6.	455 kc.	Tuning gang fully open.	Adjust tuning cores, in order given, for maximum output. (TC1 and TC3 are located at top of transformers).	TC-4—2nd i-f sec. TC3—2nd i-f pri. TC2—1st i-f sec. TC1—1st i-f pri.
2	Radiating loop	1620 kc.	1620 kc.	Adjust trimmer for maximum output.	C1-B osc.
3	Same as step 2.	1500 kc.	1500 kc.	Adjust trimmer for maximum output.	C1-A aerial (broadcast).

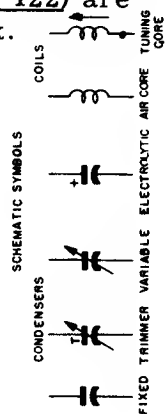

NOTES:
 ALL VOLTAGES MEASURED WITH A 20,000 OHMS-PER-VOLT VOLTMETER BETWEEN POINTS INDICATED AND B MINUS, AT A LINE VOLTAGE OF 117 V AC.
 OSCILLATOR GRID VOLTAGE MEASURED ACROSS R1, WITH A 100,000 OHM ISOLATING RESISTOR IN SERIES WITH METER.
 ALL RESISTOR VALUES ARE IN OHMS AND ALL CONDENSER VALUES IN μF UNLESS OTHERWISE MARKED.
 Ⓟ LESS THAN 1 OHM

MANUAL OF 1954 MOST-OFTEN-NEEDED RADIO DIAGRAMS

PHILCO MODEL B574, CODE 121

Model B578 is similar to Model B574, Code 121. Model B574, Code 122, is also similar but uses printed circuits. Clock-type Models B712 and B714 (Codes 121, 122, 123) use similar radio circuits to these.

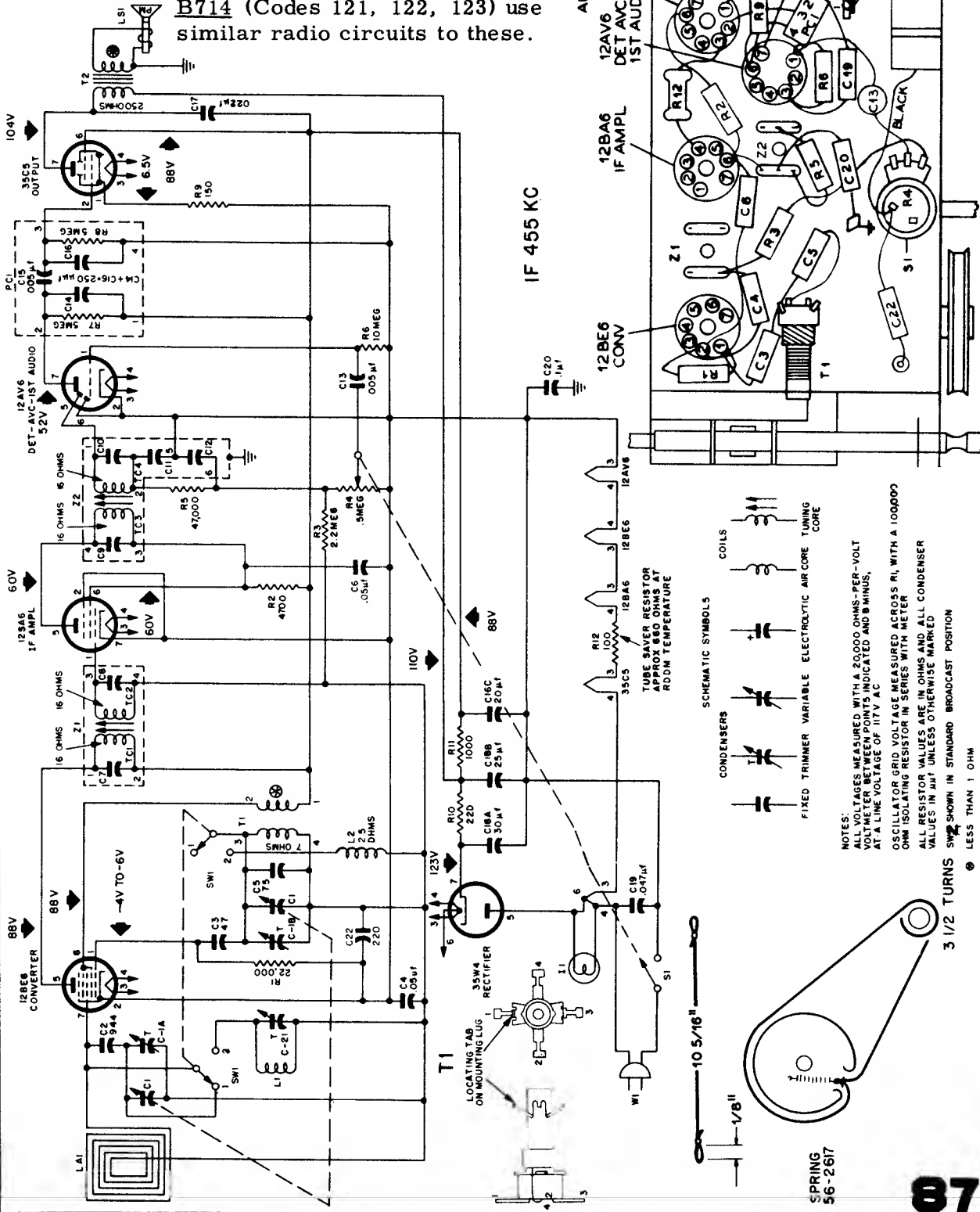

IF 455 KC

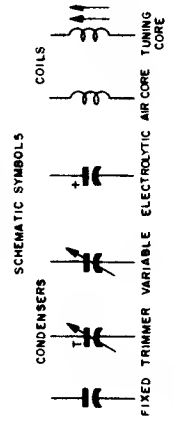

NOTES:
 ALL VOLTAGES MEASURED WITH A 20,000 OHMS-PER-VOLT VOLTMETER BETWEEN POINTS INDICATED AND B MINUS, AT A LINE VOLTAGE OF 117 V A C
 OSCILLATOR GRID VOLTAGE MEASURED ACROSS R1, WITH A 100,000 OHM ISOLATING RESISTOR IN SERIES WITH METER
 ALL RESISTOR VALUES ARE IN OHMS AND ALL CONDENSER VALUES IN μ F UNLESS OTHERWISE MARKED
 SW $\frac{1}{2}$ SHOWN IN STANDARD BROADCAST POSITION
 * LESS THAN 1 OHM

SPRING
56-2617

MANUAL OF 1954 MOST-OFTEN-NEEDED RADIO DIAGRAMS

PHILCO PORTABLE RADIO MODEL B649, MODEL B650



MODEL B650

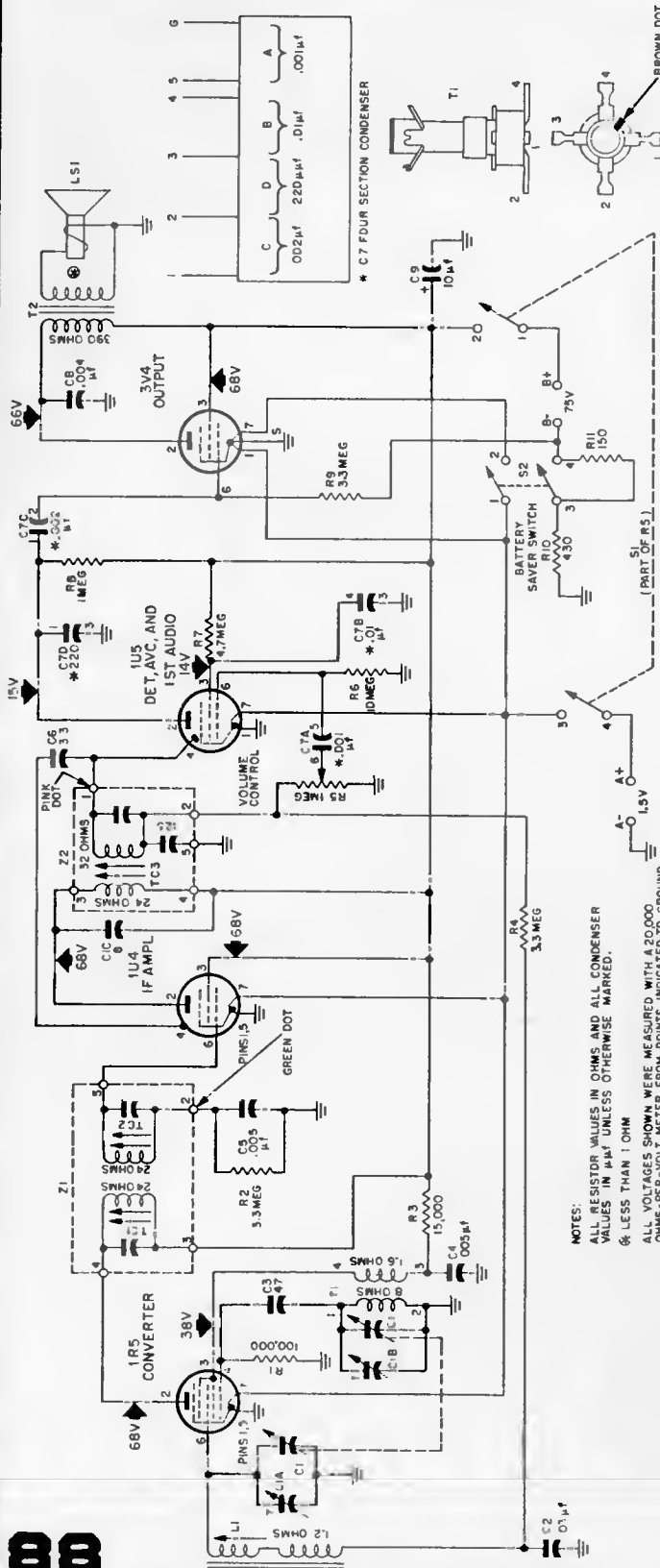

ALIGNMENT CHART

STEP	SIGNAL GENERATOR		RADIO		ADJUST
	CONNECTION TO RADIO	DIAL SETTING	DIAL SETTING	SPECIAL INSTRUCTIONS	
1	Connect signal generator through a .1- μ f. condenser to pin 6 (converter grid) of 1R5.	455 kc.	Tuning gang fully open.	Adjust for maximum output in order given.	TC3—2nd i-f sec. TC2—1st i-f sec. TC1—1st i-f pri.
2	Use radiating loop. (See NOTE 1 below.)	1620 kc.	1620 kc. (See NOTE 2 below.)	Adjust for maximum output.	C1B—osc. trimmer
3	Same as step 2.	1400 kc.	1400 kc. (See NOTE 2 below.)	Adjust for maximum output.	C1A—antenna trimmer
4	Same as step 2.	600 kc.	600 kc. (See NOTE 2 below.)	Adjust for maximum output. Rock tuning gang while making this adjustment.	L1—antenna adjusting winding
5	Repeat steps 2, 3, and 4 until no further improvement is obtained.				

NOTE 1: Use a 640-kc. turn, 6-inch-diameter loop made up of insulated wire. Connect to generator terminals, and place about one foot from radio loop.

NOTE 2: The tuning condenser can be set to the proper frequency by turning the tuning dial until the frequency setting indicated in the chart coincides with the index mark on the chassis.

MANUAL OF 1954 MOST-OFTEN-NEEDED RADIO DIAGRAMS

PHILCO RADIO-PHONOGRAPH MODEL B1352

Models similar to B1352 are B1349, B1750, B1752, and B1753.

(See the next page, over, for alignment data).

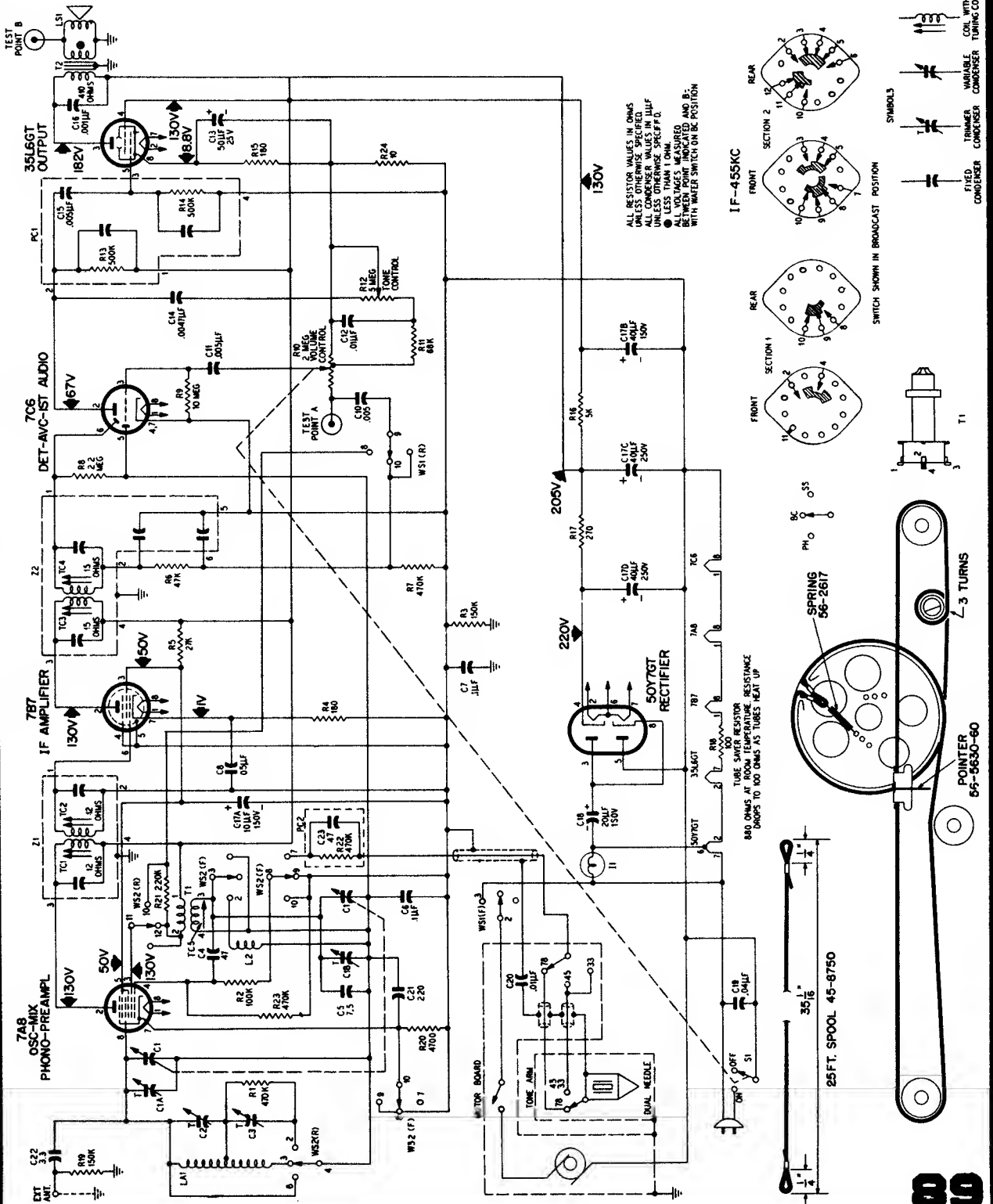

MANUAL OF 1954 MOST-OFTEN-NEEDED RADIO DIAGRAMS

Philco Model B1352 (Similar Models are B1349, B1750, B1752, B1753)

(Continued from the preceding page, on other side.)

ALIGNMENT PROCEDURE

GENERAL—In order to perform the alignment procedure, it is necessary to remove the chassis from the cabinet. This can be done by first removing the cabinet bottom and then removing the chassis mounting board. Be careful not to break the Magnecor antenna leads when removing the chassis.

CONTROLS—Set the volume control to maximum, and the tone control to the treble position. Set the wafer switch, WS1, to the broadcast position for the first three steps of the procedure, and to the Special Services position for the last step. Set the tuning control as indicated in the chart.

OUTPUT INDICATOR—Connect the output indicator (a 1000-ohms-per-volt voltmeter or an oscilloscope) between test point B (located on the antenna terminal board) and ground. (Location of test point B is shown in figure 2.)

SIGNAL GENERATOR—Use an amplitude-modulated r-f generator. Connect the ground lead to B minus and the output lead as indicated in the chart.

OUTPUT LEVEL—During the alignment, attenuate the signal-generator output to maintain the output indication below 1 volt.

ALIGNMENT CHART

STEP	SIGNAL GENERATOR		RADIO		ADJUST
	CONNECTION TO RADIO	DIAL SETTING	DIAL SETTING	SPECIAL INSTRUCTIONS	
1	Connect output lead through a .01- μ f condenser to control grid (pin 6) of 7A8 osc.-mixer tube.	455 kc. (modulated)	Gang fully open.	Adjust in order given in next column, for maximum output. TC2 and TC4 are located at top of transformers.	TC4—2nd i-f sec. TC3—2nd i-f pri. TC2—1st i-f sec. TC1—1st i-f pri.
2	See NOTE 1 below.	1620 kc.	1620 kc (see NOTE 2 below).	Adjust for maximum output.	C1B—oscillator trimmer
3	Same as step 2.	580 kc.	580 kc.	Adjust for maximum output.	TC5—oscillator tuning core
4	Same as step 2.	1500 kc.	1500 kc.	Adjust for maximum output.	C1A—antenna trimmer (Broadcast)
5	Same as step 2.	3200 kc.	3200 kc.	Adjust for maximum output.	C2—antenna trimmer (Special Services)

NOTE 1: If the Magnecor antenna is used, make up a 6–8 turn, 6-inch-diameter test loop from insulated wire; connect to signal-generator leads, and place near the Magnecor antenna. If an external antenna is used, connect the signal generator to the external antenna lead.

NOTE 2: The tuning gang can be set to 1620 kc. by placing a piece of 6-mil flat shim stock between the heel of the rotor and the top of the stator plates, and rotating the rotor until it holds the shim in place. Remove the shim before proceeding with the alignment. Be careful not to disturb the setting of the gang when removing the shim.

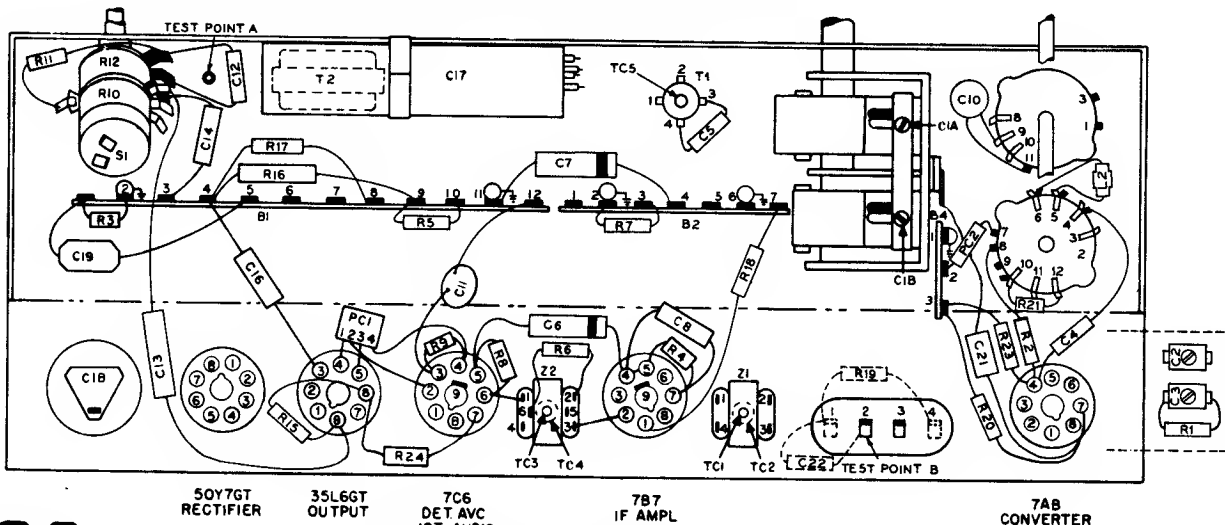

90

Base View, Showing Parts Placement

MANUAL OF 1954 MOST-OFTEN-NEEDED RADIO DIAGRAMS



RCA VICTOR

MODELS 3-HES-5, 3-HES-5A

Chassis No. RS-146, RS-146X

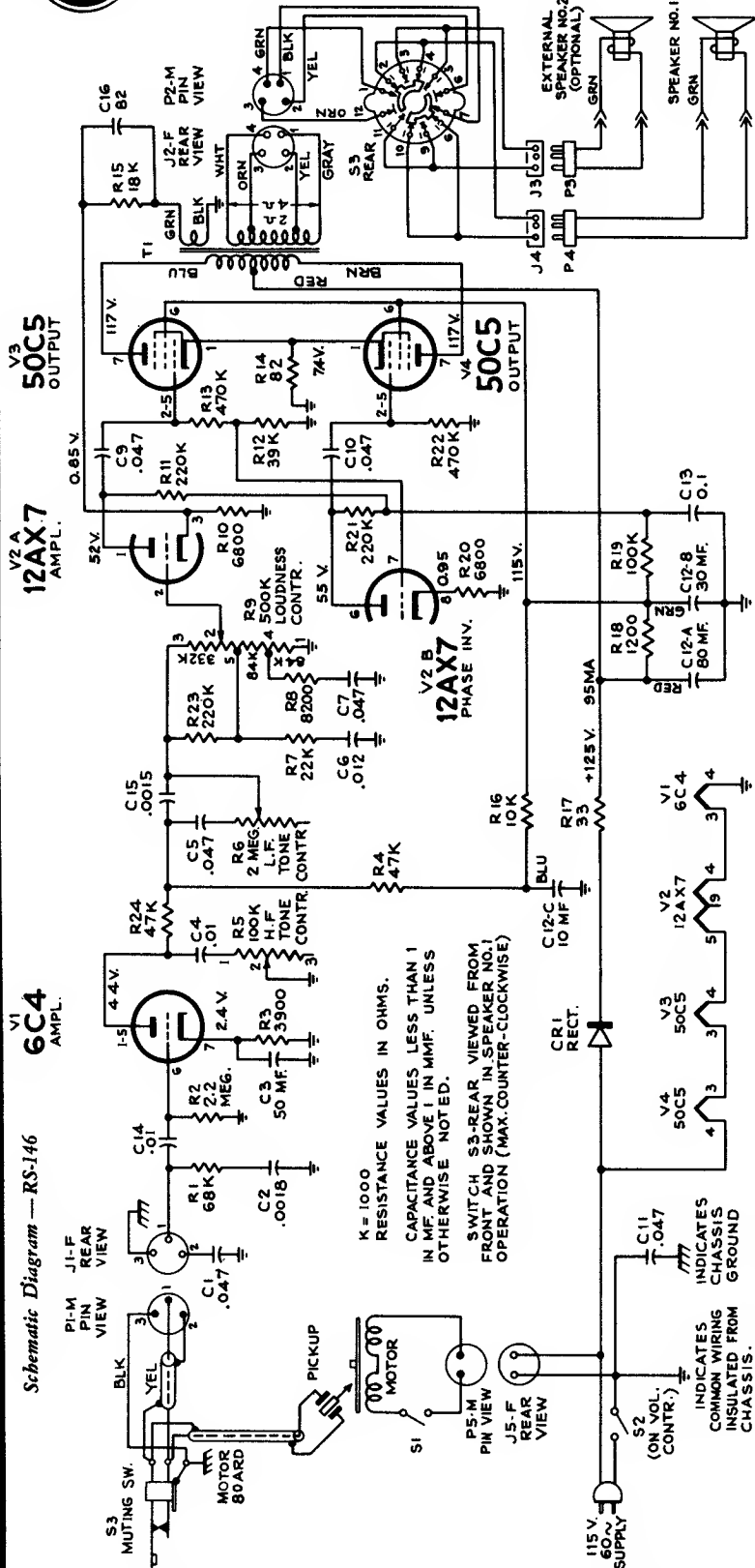

Hum:

An electrostatic condition has been found to cause an accumulation of metallic dust and minute cuttings between the loudness control terminals and the chassis apron. This causes a partial short circuit and has been found to be the cause of a hum which is difficult to locate. Late production chassis have a coating of black insulating paint at this point.

The loudness control should be examined when any of these chassis are serviced. This space may be cleaned with an air blast or with a soft brush.

Electrolytic Capacitor:

The three-section electrolytic capacitor used in this chassis is of a specially selected type of construction. If replacement should be made with other than the specified replacement part (Stock No. 78617), excessive hum may be present. This hum may be due to excessive coupling between sections. If such should be the case, it is advisable to use a separate capacitor for C12C.

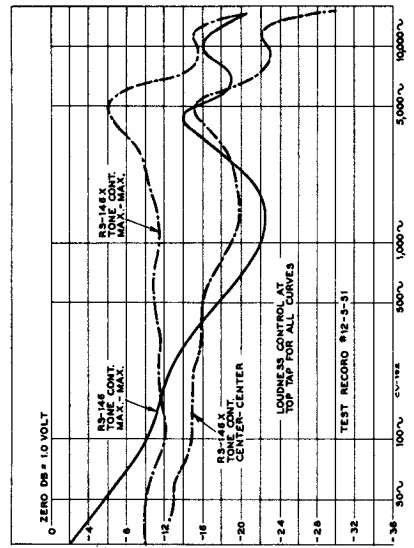

Overall Frequency Response using Test Record

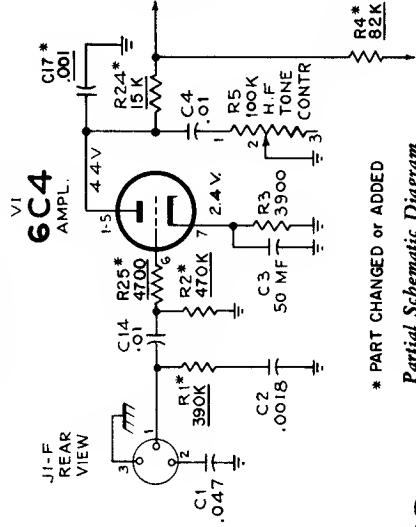

Partial Schematic Diagram RS-146X (otherwise same as RS-146)

MANUAL OF 1954 MOST-OFTEN-NEEDED RADIO DIAGRAMS

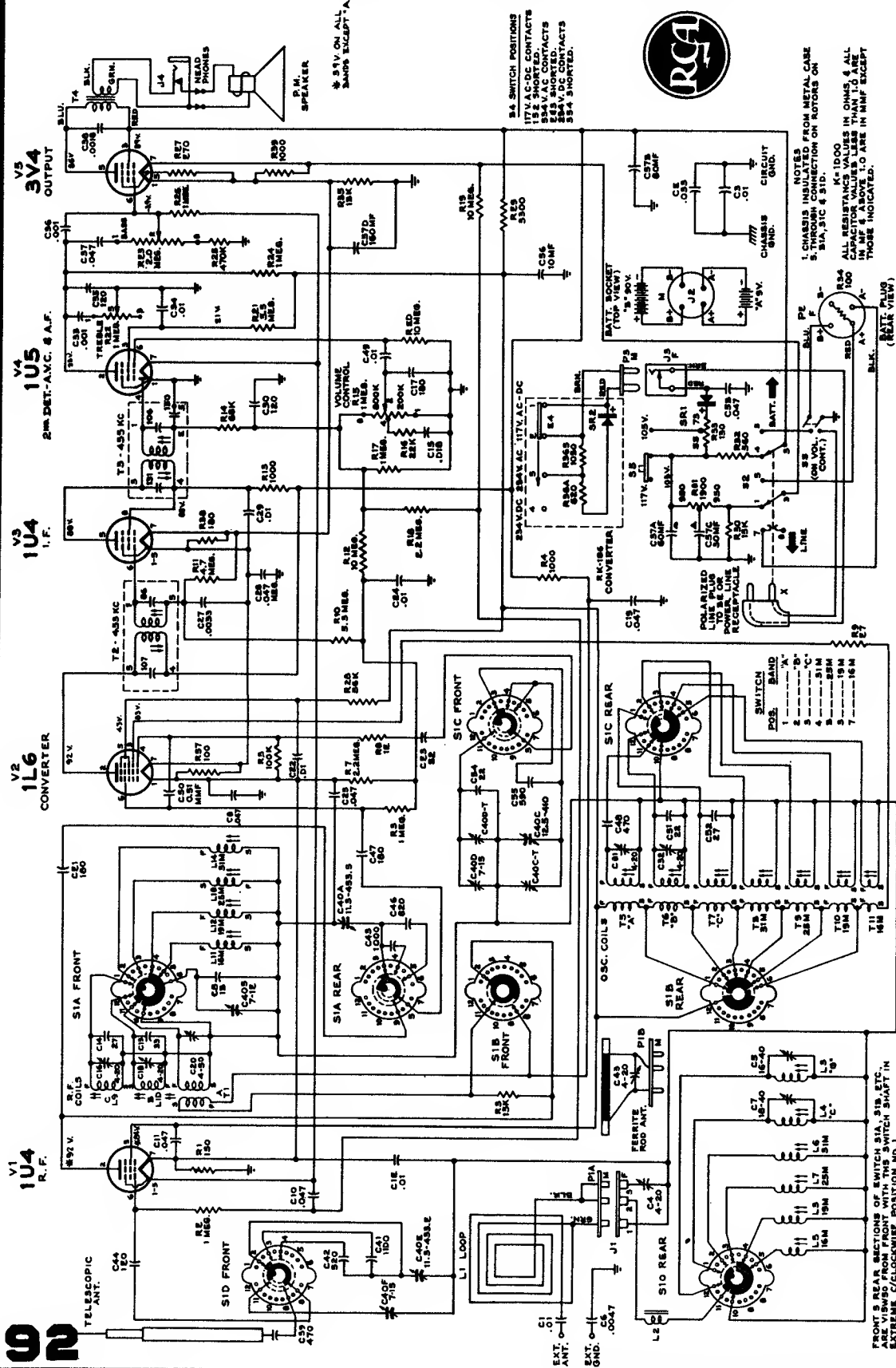

RCA VICTOR Models 3-BX-671, 3-BX-672
 Chassis No. RC-1125

CAUTION -
 Do not remove any tubes from the chassis with the set operating and the plug connected to the power line. Damage to tubes may result.

* 250V ON ALL TUBES EXCEPT V1.

5-4 SWITCH POSITIONS
 117V AC-DC CONTACTS
 117V AC-DC CONTACTS
 117V AC-DC CONTACTS
 117V AC-DC CONTACTS
 117V AC-DC CONTACTS

NOTES
 1. CHASSIS INSULATED FROM METAL CASE
 2. 117V AC-DC CONTACTS
 3. 117V AC-DC CONTACTS
 4. 117V AC-DC CONTACTS
 5. 117V AC-DC CONTACTS

ALL RESISTANCE VALUES IN OHMS, & ALL CAPACITANCE VALUES IN MICROFARADS, UNLESS OTHERWISE INDICATED.

FRONT & REAR SECTIONS OF SWITCH S1A, S1B, ETC., ARE VIEWED FROM FRONT WITH THIS SWITCH SHOWN IN EXTREME CLOCKWISE POSITION NO. 1.

POLARIZED POWER LINE TO BE USED TO PREVENT INTERFERENCE TO OTHER RECEIVERS.

OSC. COILS
 T1
 T2
 T3
 T4
 T5
 T6
 T7
 T8
 T9
 T10
 T11

EXT. ANT. C1
 EXT. ANT. C2
 EXT. ANT. C3

MANUAL OF 1954 MOST-OFTEN-NEEDED RADIO DIAGRAMS

Alignment Procedure

RCA Victor Models 3-BX-671, 3-BX-672
(Continued from adjacent page, at left)

Close gang and set dial pointer to mark on dial plate. Turn volume and treble tone controls to maximum clockwise position. Turn bass tone control to maximum counterclockwise position.

STEP	CONNECT HIGH SIDE OF SIG. GEN. TO—	SIGNAL GEN. OUTPUT	DIAL POINTER SETTING	ADJUST FOR MAXIMUM OUTPUT	
1.	Pin #6 of 1L6 Conv. thru 0.01 mid.	455 kc	"A" Band Quiet point near 1600 kc	T3 top and bottom cores	
2.				T2 top and bottom cores	
3.	Install bottom cover. Secure aluminum alignment fixture in place. Connect 24 mmfd. in series with 22 ohms between sig. generator lead and C39.				
4.	C39, term. 7 on SID thru dummy load indicated	18.25 mc	16M Band Right hand stop	*C40D-T top of gang	
5.		17.5 mc	16M Band Left hand stop	T11 Osc.	
6.		17.8 mc	16M Band 17.8 mc Signal	Rock gang, —Peak L11 R.F. + L5 Ant.	
7.		14.9 mc	19M Band Left hand stop	T10 Osc.	
8.		15.2 mc	19M Band 15.2 mc Signal	Rock gang, —Peak L12 R.F. + L6 Ant.	
9.		11.55 mc	25M Band Left hand stop	T9 Osc.	
10.		11.8 mc	25M Band 11.8 mc Signal	Rock gang, —Peak L13 R.F. + L7 Ant.	
11.		9.45 mc	31M Band Left hand stop	T8 Osc.	
12.		9.6 mc	31M Band 9.6 mc Signal	Rock gang, —Peak L14 R.F. + L8 Ant.	
13.		8.1 mc	"C" Band Right hand stop	*C40C-T top of gang. C16 R.F. C7 Ant.	
14.		3.9 mc	"C" Band Left hand stop	T7 Osc. L9 R.F. L4 Ant.	
15.		Repeat steps 13 and 14 until maximum gain is obtained.			
16.		4.05 mc	"B" Band Right hand stop	C32 Osc. C18 R.F. C5 Ant.	
17.		1.97 mc	"B" Band Left hand stop	T6 Osc. L10 R.F. L3 Ant.	
18.		Repeat steps 16 and 17 until maximum gain is obtained. Remove alignment fixture and install chassis in cabinet. Plug in loop cable.			

19.	Short length of wire near receiver	1620 kc	"A" Band Right hand stop	C31 Osc.
20.		1400 kc	"A" Band 1400 kc Signal	C20 R.F. C4 Ant.
21.		600 kc	"A" Band 600 kc Signal	Rock gang, —Peak T5 Osc. trans. + T1 R.F.
22.		Repeat steps 19, 20 and 21 until maximum gain is obtained. Exchange loop antenna plug with external Ferrite Rod antenna plug. Extend cable to maximum.		
23.		1400 kc	"A" Band 1400 kc Signal	C43 Ferrite Rod Ant.

*The tuning range and dial calibration of the succeeding bands depend upon the accuracy of this adjustment. Avoid aligning on image. The local oscillator is 455 kc higher in frequency than the RF on all bands.

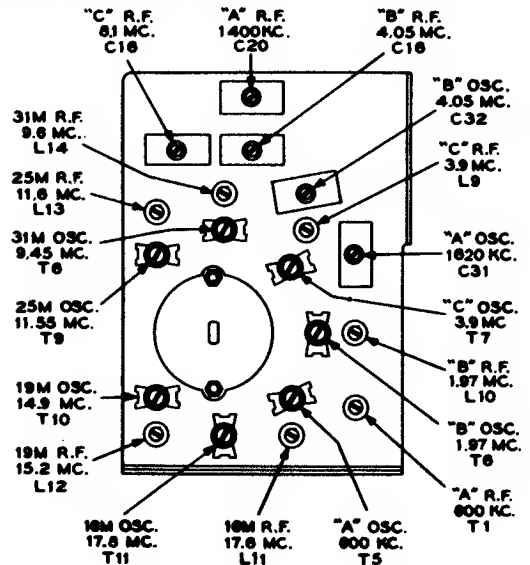

Tuner Adjustment Locations—Oscillator and R.F.

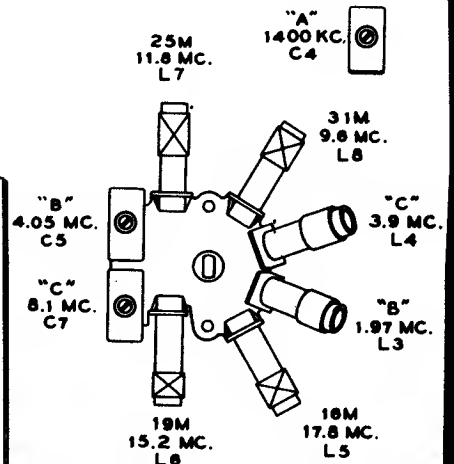

Tuner Adjustment Locations—Antenna

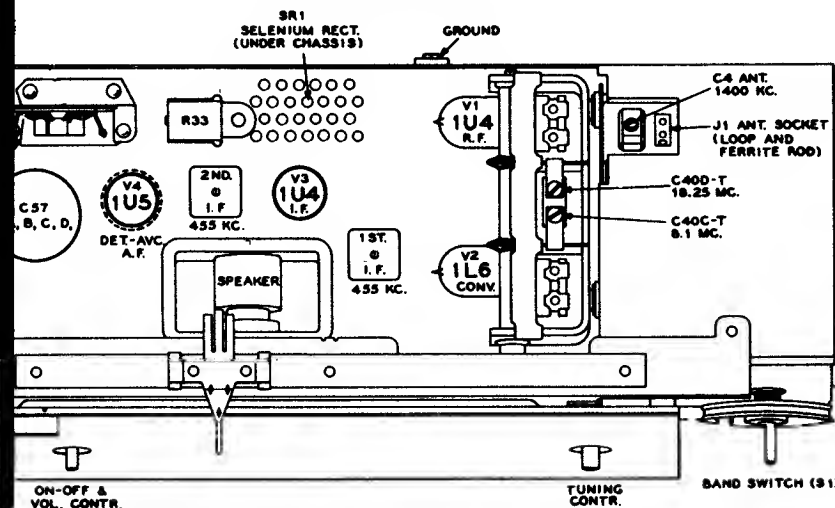

MANUAL OF 1954 MOST-OFTEN-NEEDED RADIO DIAGRAMS

RCA VICTOR

AC-DC Radio Receiver

Model 4-X-641

Chassis No. RC-1140

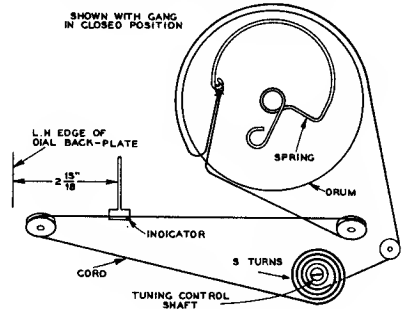

Dial Indicator and Drive Mechanism

ALIGNMENT PROCEDURE

Output Meter Alignment.—If this method is used, connect the meter across the voice coil and turn the receiver volume control to maximum.

Test Oscillator.—Connect low side of test oscillator to common wiring in series with a .1 mf. capacitor. If the test oscillator is a.c. operated it may be necessary to use an isolation transformer for the receiver during alignment and the low side of the test oscillator connected directly to common wiring at the electrolytic capacitor. Keep the oscillator output low to prevent a-v-c action.

Step	Connect high side of sig. gen. to—	Sig. gen. output	Turn radio dial to—	Adjust for—
1	Pin No. 7 of 12BE6 (V2 conv.)	455 kc	Quiet point near 600 kc	Top and bottom cores of T3 and T4
2		1620 kc	Gang open	*C1-B Osc.
3		1400 kc	1400 kc signal	C1-A R.F. C1-C Ant.
4	"External Antenna" terminal	Shunt C1-A with 22,000 ohm resistor		
		600 kc	600 kc	T2 Osc. (Rock gang)
5		Remove 22,000 ohm resistor from C1-A		
		600 kc	600 kc	T1 R.F.
6		Repeat steps 3, 4 and 5		

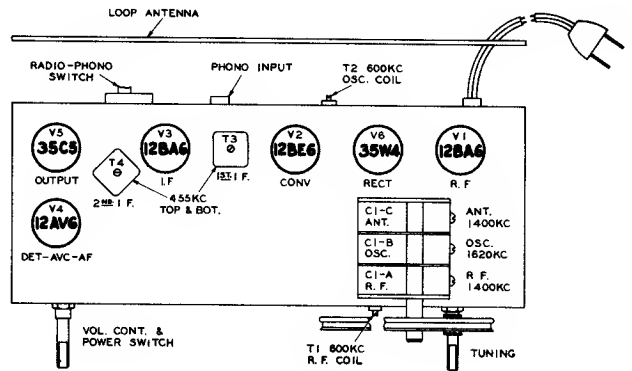

Tube and Trimmer Locations

Power Output

Undistorted 0.8 watt

Maximum 1.2 watts

Tuning Drive Ratio 10 to 1 (5 turns of knob)

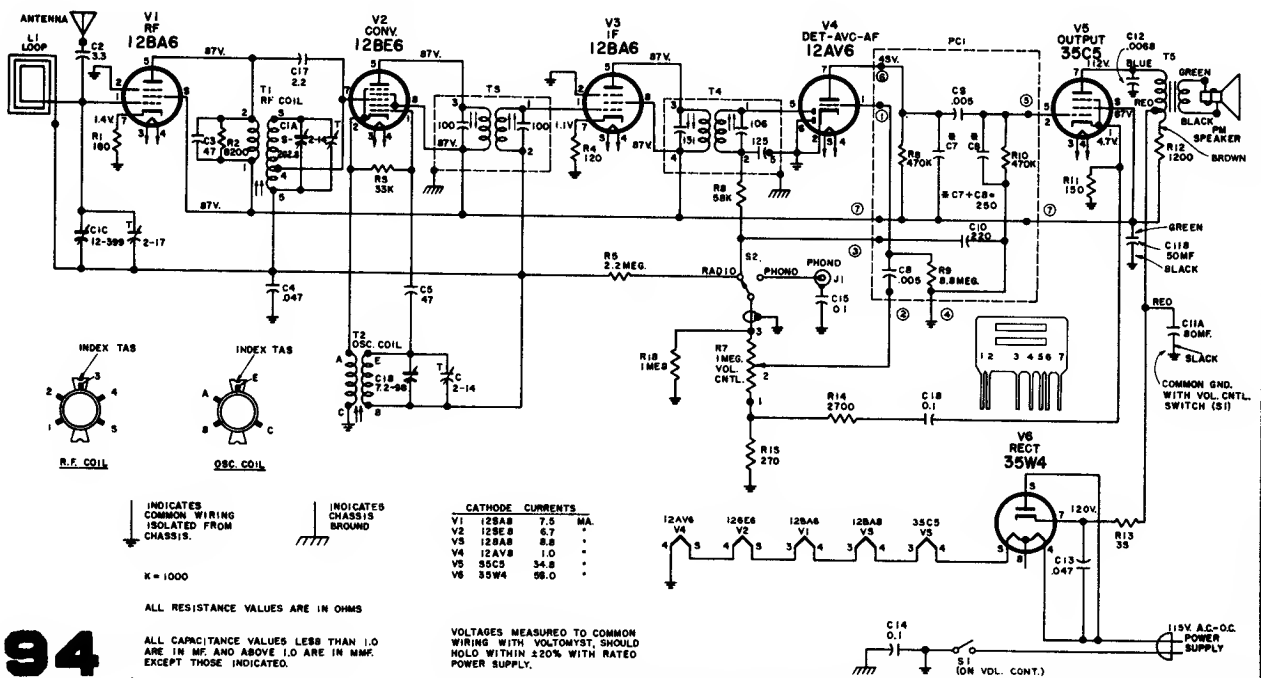

INDICATES COMMON WIRING ISOLATED FROM CHASSIS.

INDICATES CHASSIS BROWN

INDICATES COMMON GND. WITH VOL. CNTL. SWITCH (S1)

K = 1000

ALL RESISTANCE VALUES ARE IN OHMS

CATHODE CURRENTS	
V1 12BA6	7.5 MA.
V2 12BE6	6.7 "
V3 12BA6	8.8 "
V4 12AV6	1.0 "
V5 35C5	34.8 "
V6 35W4	56.0 "

ALL CAPACITANCE VALUES LESS THAN 1.0 ARE IN MF. AND ABOVE 1.0 ARE IN MMF. EXCEPT THOSE INDICATED.

VOLTAGES MEASURED TO COMMON WIRING WITH VOLTMETER, SHOULD HOLD WITHIN ±20% WITH RATED POWER SUPPLY.

MANUAL OF 1954 MOST-OFTEN-NEEDED RADIO DIAGRAMS

RCA VICTOR RP-197-1

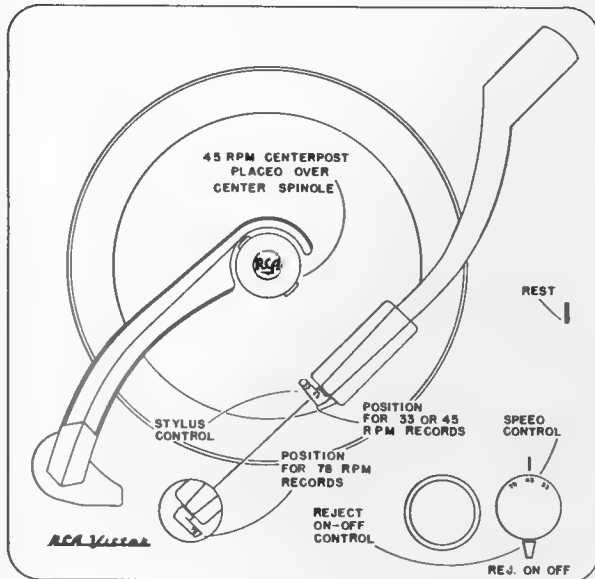

Figure 1—Controls

LANDING ADJUSTMENT

Only one landing adjustment is necessary. The landing position of the stylus is adjusted by means of the round head screw at the side of the pickup arm support bracket. When adjusted for correct landing on one size of record, the landing position for other sizes of records is automatically corrected.

PICKUP ARM HEIGHT ADJUSTMENT

The pickup arm height during cycle is adjusted by means of the hex head screw, located in the pickup arm.

Turn control knob to "REJ" and rotate turntable by hand until arm has risen to its maximum height. Adjust screw so that stylus is $1\frac{1}{4}$ " above turntable.

RECORD DROPPING ADJUSTMENT

The eccentric stud (Ill. No. 101) on the end of the cycling slide controls the time during cycle at which the record drops to the turntable.

Adjust the position of the stud so that the record drops to the turntable when the pickup arm has moved to its maximum outward travel. If the record drops too soon it will strike the pickup arm. If timed too late the record may not drop.

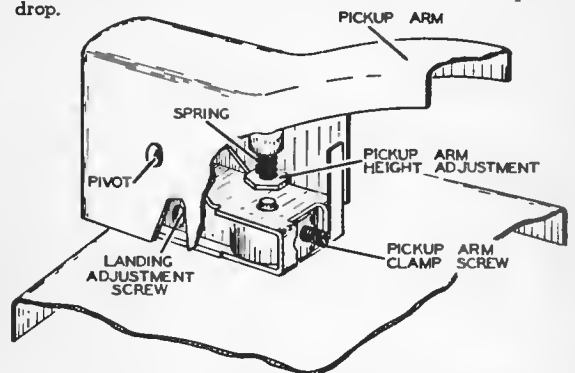

Fig. 3—Pickup Arm Height and Landing Adjustments

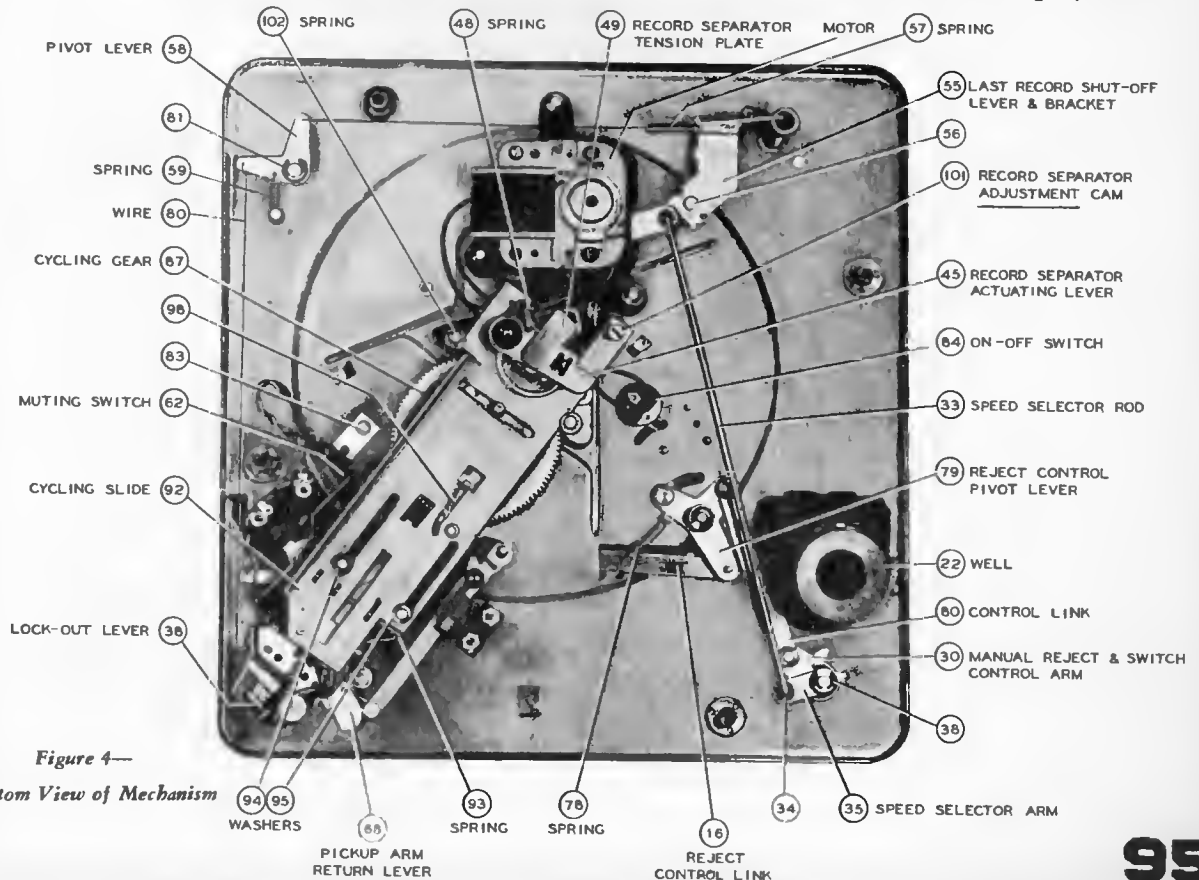
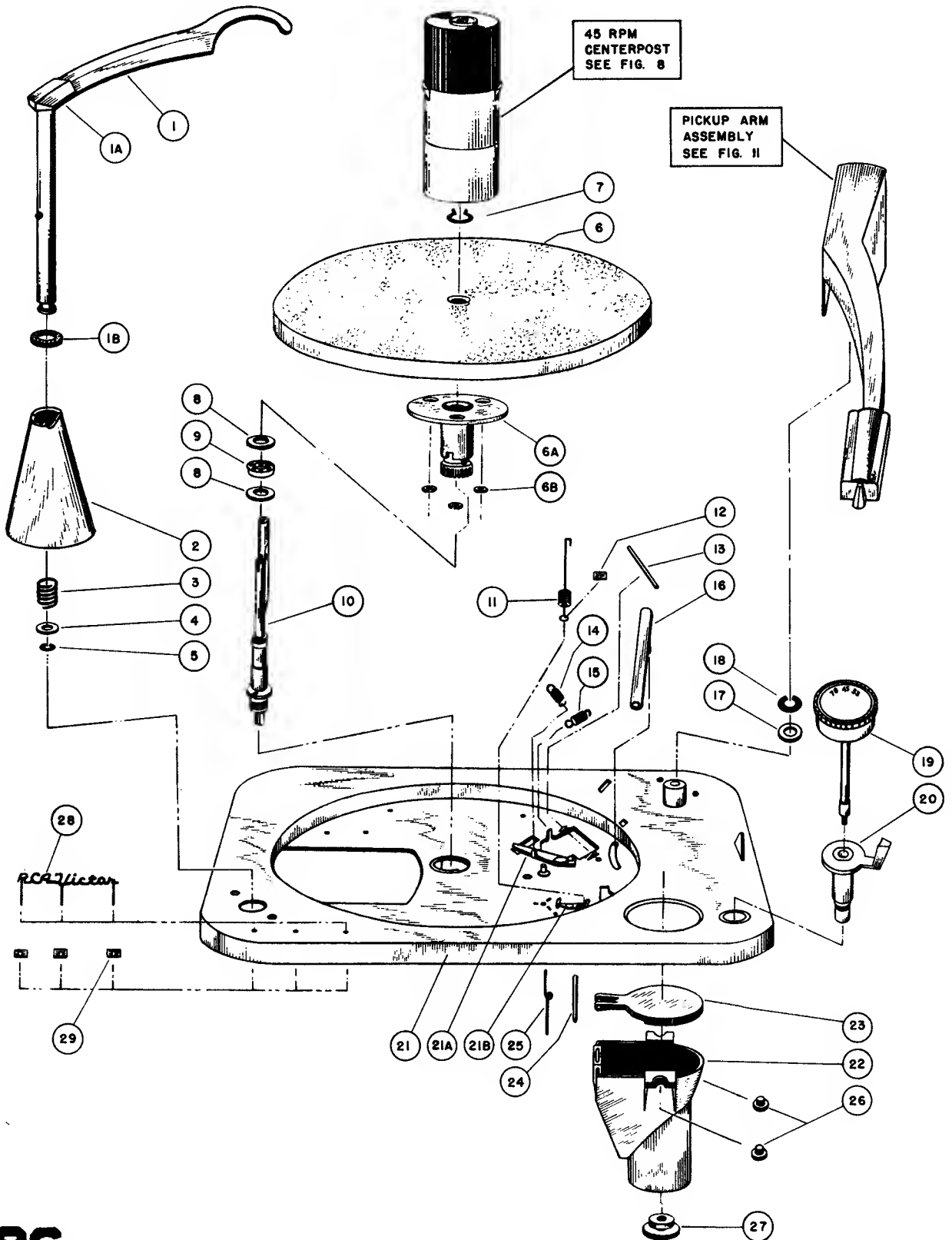

Figure 4—

Bottom View of Mechanism

MANUAL OF 1954 MOST-OFTEN-NEEDED RADIO DIAGRAMS

RCA Victor Record Changer RP-197-1 (Continued)



MANUAL OF 1954 MOST-OFTEN-NEEDED RADIO DIAGRAMS

RCA Victor Record Changer RP-197-1 (Continued)

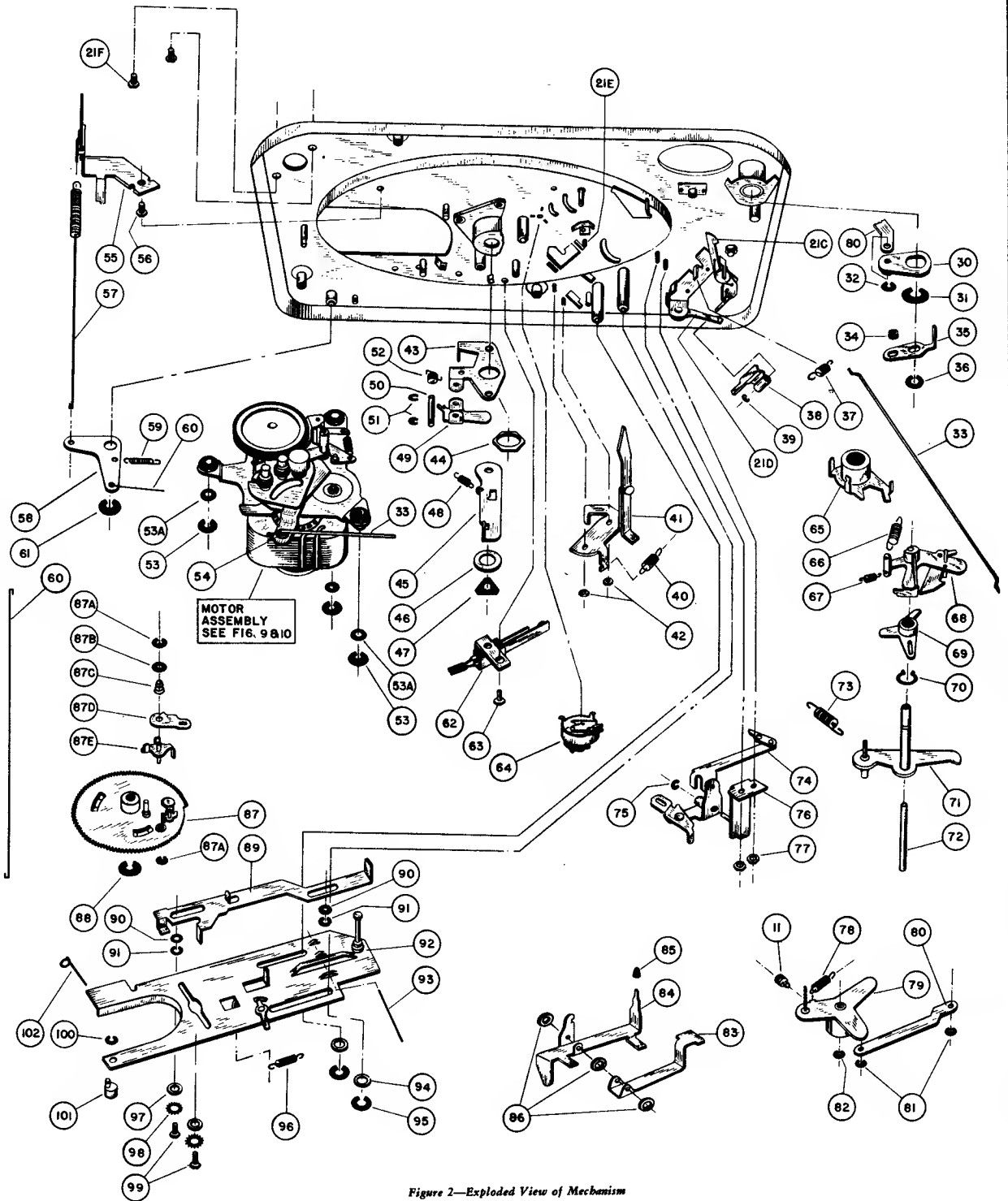

Figure 2—Exploded View of Mechanism

MANUAL OF 1954 MOST-OFTEN-NEEDED RADIO DIAGRAMS

RCA Victor Record Changer RP-197-1

REPLACEMENT PARTS

(Continued)

ILL. NO.	STOCK NO.	DESCRIPTION	ILL. NO.	STOCK NO.	DESCRIPTION	ILL. NO.	STOCK NO.	DESCRIPTION
1	78717	RP-197-1 RECORD CHANGER (See pages 8, 9 and 10 for centerpost, motors and pickup arm)	69	78724	Lever—Reject lever arm assembly complete with stud	77	78710	Nut—#6-32
1A	78677	Arm—Stabilizer arm complete with shaft and plastic cap	70	78653	Washer—Control lever retaining washer	78	78710	Spring—Return spring for switch and reject lever
1B	78683	Cap—Plastic cap for stabilizer arm	71	79091	Washer—"C" type retaining washer (406" O.D., .125" I.D.)	79	78662	Lever—Switch and reject lever assembly
2	78700	Washer—Cork washer for stabilizer arm	72	78672	Rod—Motor speed selector rod	80	78673	Link—Control link for "On-Off Reject"
3	78708	Support—Record stabilizer support	73	78698	Grommet—Motor mounting grommets	81	33726	Washer—"C" type retaining washer (406" O.D., .125" I.D.)
4	78650	Spring—Return spring for stabilizer arm	74	78695	Washer—"C" type retaining washer (500" O.D., .183" I.D.)	82	35969	Washer—"C" type retaining washer (500" O.D., .183" I.D.)
5	33726	Washer—"C" type retaining washer (406" O.D., .125" I.D.)	75	96138	Spring—Return spring for pickup arm latch, 200" O.D., .625" free length	83	78689	Lever—Landing selector lever
6	78703	Turntable—Turntable assembly complete with hub and gear	76	78664	Lever—Actuating lever for pickup arm latch	84	78690	Lever—Index lever for 10" records
7	78654	Ring—Retaining ring for spindle	77	78664	Washer—Flat metal washer (500" O.D., .158" I.D.)	85	78666	Cushion—Rubber cushion for 10" index lever
8	78720	Washer—Flat washer for turntable thrust bearing	78	78710	Washer—Flat metal washer (500" O.D., .158" I.D.)	86	78721	Washer—Flat washer for landing control bearing pin
9	78660	Bearing—Thrust bearing for turntable	79	79092	Washer—Flat metal washer (500" O.D., .158" I.D.)	87	78691	Gear—Cycling gear assembly complete with 87A, 87B, 87C, 87D, 87E
10	79242	Spindle—Spindle assembly	40	78712	Spring—Return spring for index lever	87A	78651	Washer—"C" type retaining washer
11	78680	Spring—Reject lever spring	41	78692	Lever—Index lever assembly for 12" records	87B	79240	Washer—Flat washer for trip pawl pressure spring
12	71095	Nut—Speed nut for switch and reject lever assembly	42	78656	Nut—#6-32 nut	87C	78727	Spring—Trip pawl pressure spring
13	78659	Pin—Bearing pin for landing selector levers #83 & #84	43	78656	Bracket—Spindle mounting bracket assembly complete with stud	87D	78725	Lever—Trip pawl actuating lever
14	78747	Spring—Coil spring for motorboard assembly .200" O.D., .531" free length, 13 turns	44	78670	Nut—1/2"-32 hex nut	87E	78726	Lever—Trip pawl intermediate lever
15	78709	Spring—Return spring for landing selector lever	45	78670	Arm—Spindle operating arm assembly	88	35969	Washer—"C" type retaining washer (500" O.D., .183" I.D.)
16	78663	Link—Reject link assembly complete with stud	46	78670	Washer—Flat metal washer, 5/8" O.D., .158" I.D.	89	78688	Lever—Trip slide lever
17	78649	Washer—Flat washer for pickup arm pivot shaft	47	79353	Retainer—Triangular push-on retainer	90	78719	Washer—"C" type retaining washer (406" O.D., .125" I.D.)
18	35969	Washer—"C" type retaining washer (500" O.D., .183" I.D.)	48	78711	Spring—Return spring for spindle operating arm	91	33726	Washer—"C" type retaining washer (406" O.D., .125" I.D.)
19	78704	Knob—Speed control knob assembly	49	78657	Lever—Spindle reset lever	92	78701	Slide—Cycling slide assembly
20	78696	Lever—"On-Off-Reject" control lever	50	78694	Pin—Pivot pin for spindle reset lever	93	Wire—Music wire PS #45 .059" dia. stock 2 1/4" long
21	78697	Motorboard—Motorboard assembly complete with stabilizer housing and all welded and stacked parts (includes 21A, 21B, 21C, 21D)	51	96138	Washer—"C" type retaining ring for mounting bracket	94	75749	Washer—Flat washer for motor and slide assembly
21C	78669	Lever—Tone arm latch lever assembly	52	78745	Spring—Actuating spring for reset lever	95	33726	Washer—"C" type retaining washer (406" O.D., .125" I.D.)
21D	Screw—H.H.S.T. #4 x 1/4"	53	33726	Washer—"C" type retaining washer (406" O.D., .125" I.D.)	96	78705	Spring—Actuating spring for escape shut-off lever
21E	Screw—#8 x 3/4" H.H.S.T.	53A	75749	Washer—Flat washer for motor mounting	97	Washer—#6-3/8" I.D., 3/8" O.D.
21F	Well—45 r.p.m. centerpost well—less lid and grommet	54	33139	Grommet—Motor mounting grommets	98	Lock washer—Ext. #6
22	76921	Lid—45 r.p.m. centerpost well	55	78674	Lever—Shut-off lever assembly	99	Screw—H.H. #6-32 x 3/8"
23	78671	Pin—45 r.p.m. centerpost well pin	56	78681	Screw—H.H.S.T. #8 x 3/8"	100	78722	Washer—Spring retaining washer for eccentric stud
24	78746	Spring—45 r.p.m. centerpost well spring	57	78675	Spring—Shut-off lever spring	101	78685	Stud—Eccentric stud for drop adjustment
25	Screw—Pan hd. machine #10-32 x 3/8" long	58	78675	Arm—Transfer arm for shut-off mechanism	102	79352	Spring—Formed wire spring for slide assembly
26	Grommet—Rubber grommet for well	59	78714	Spring—Return spring for transfer arm			
27	76940	Nameplate—"RCA Victor" nameplate	60	78679	Wire—Shut-off wire			
28	77013	Nut—Speed nut for "RCA Victor" nameplate	61	35969	Washer—"C" type retaining washer (500" O.D., .183" I.D.)			
29		62	78676	Switch—Muting switch assembly			
			63	76301	Screw—H.H.S.T. #8 x 3/8"			
			64	78661	Switch—"On-Off" switch S.P.S.T.			
			65	78661	Lever—Selecting lever			
			66	78713	Spring—Return spring for pickup arm return lever			
			67	78699	Spring—Return spring for pickup arm return lever actuating lever			
			68	78655	Lever—Pickup arm return lever assembly			

MANUAL OF 1954 MOST-OFTEN-NEEDED RADIO DIAGRAMS

RCA Victor Record Changer RP-197-1 (Continued)

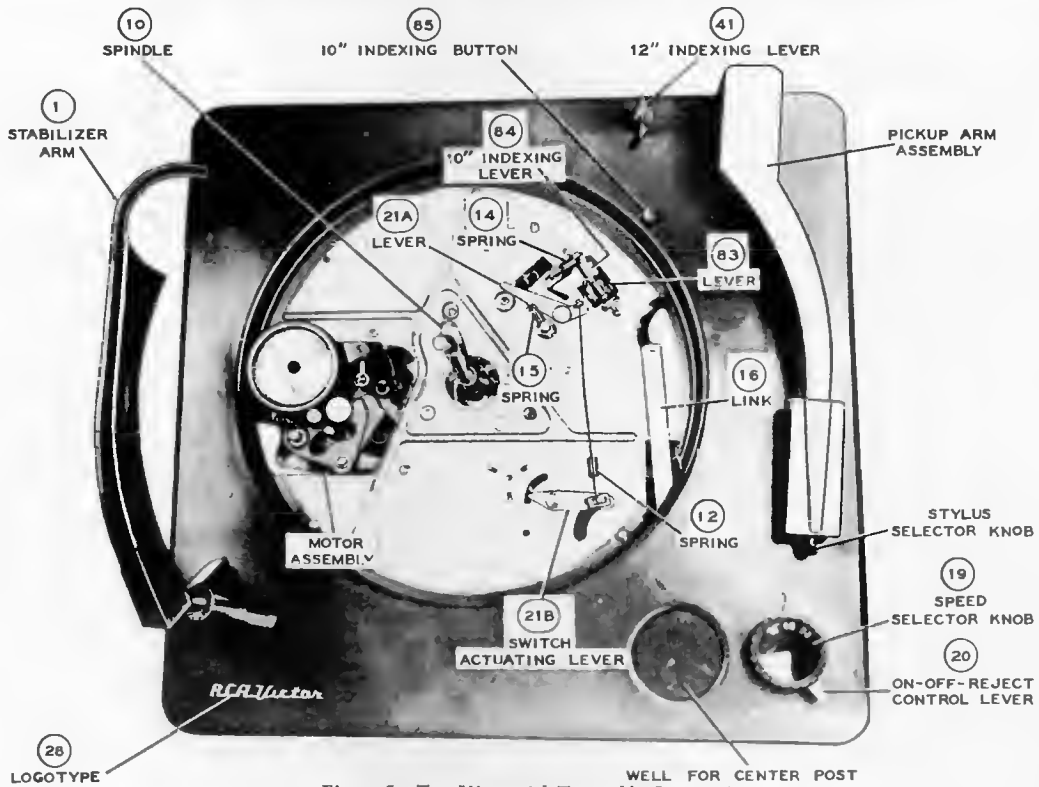

Figure 5—Top View with Turntable Removed

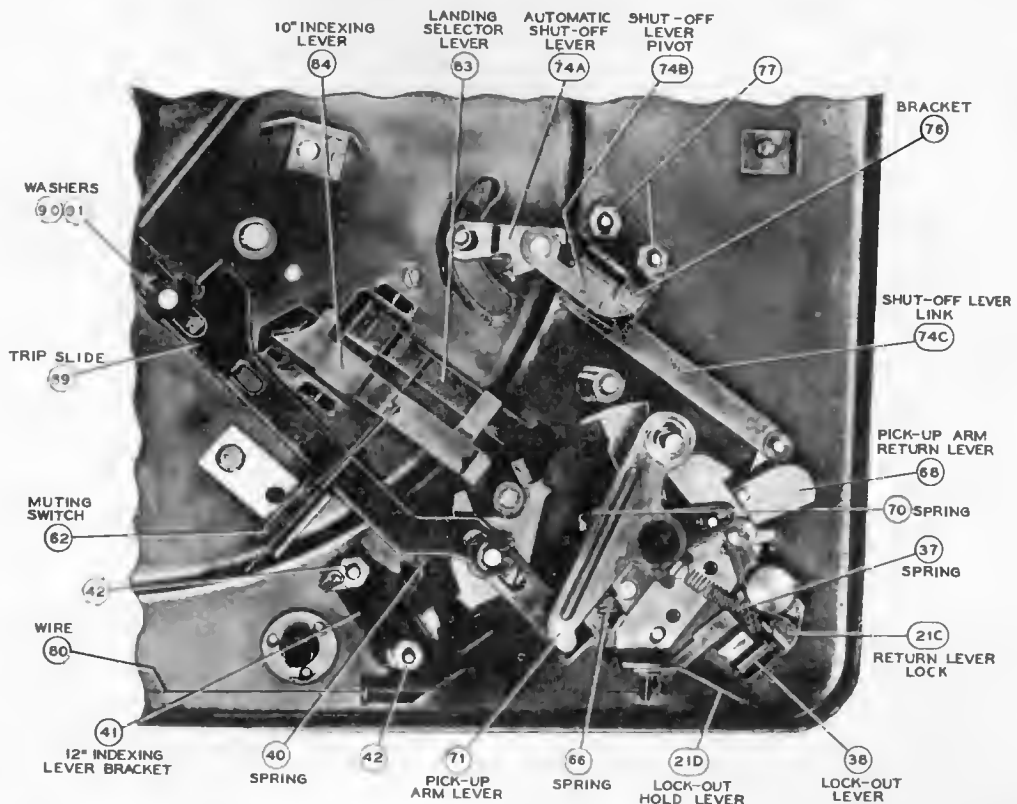

Figure 6—Partial Bottom View with Cycling Slide Removed

MANUAL OF 1954 MOST-OFTEN-NEEDED RADIO DIAGRAMS

RCA Victor Record Changer RP-197-1 (Continued)

REPLACEMENT PARTS

ILL. NO.	STOCK NO.	DESCRIPTION
	79096	45 R.P.M. CENTERPOST Centerpost—45 r.p.m. centerpost complete
1	79201	Cap—Nose cap
2	79203	Knife—Record separator knife (1 set)
3	79202	Spring—Record separator knife spring
4	79204	Lever—Actuator lever assembly
5	79205	Shelf—Record support shelf
6	79206	Spring—Record support shelf spring (16 turns)
7	Body—Centerpost body assembly
8	79207	Screw—#4-40 screw for nose cap
9	79208	Washer—Fibre washer
10	Rotor—Die cast rotor
11	76954	Spring—Rotor lift spring (coil) (1.168" O.D. x 1"—4-5 turns)
12	79209	Lift—Rotor lift
13	79210	Retainer—Rotor lift retainer (8 tooth)

OPERATION OF 45 R.P.M. CENTERPOST

In the out of cycle position (playing), the 45 r.p.m. records (with 1½" centerhole) rest upon the protruding shelves of the centerpost (knives are retracted).

When the mechanism goes through cycle, the record push-off finger of the ¼" center spindle pushes against the actuator lever. This lever is pivoted and pushes outward on both separator knives. The knives will then support all records except the bottom record.

Projecting tabs on each knife engage the OPPOSITE shelf and thus retract the shelves and allow the bottom record to fall to the turntable. As the push-off finger moves back to the normal position, one pair of springs pull the knives inward and another pair of knives push outward on the shelves. The stack of records then drop slightly and rest upon the shelves.

Careless placement or removal of the 45 r.p.m. centerpost on the center spindle may result in bending of the center spindle. The 45 r.p.m. centerpost should be placed on or removed from the center spindle with a STRAIGHT VERTICAL MOTION.

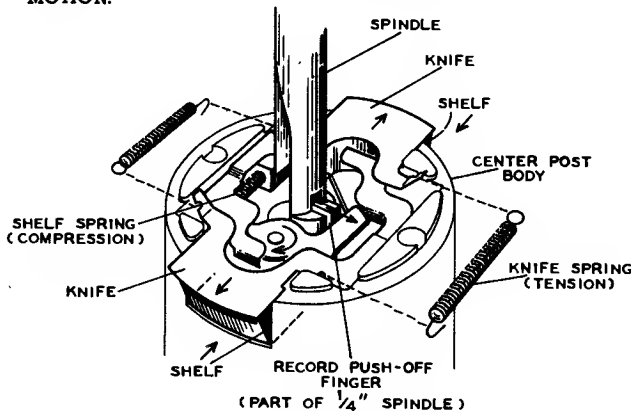

Figure 7—Centerpost Operation

LUBRICATION

The mechanism is properly lubricated when it leaves the factory, additional lubrication should not be necessary for a long period of time.

Oil bearings of motor and rotating levers sparingly with high quality light machine oil.

Apply a medium weight clinging type of grease to points of sliding contact including tabs of cycling gear.

It is important that the drive motor spindle, all rubber tires and the inside rim of the turntable be kept clean and free of oil and grease.

Carbon tetrachloride or naphtha is recommended for cleaning these parts.

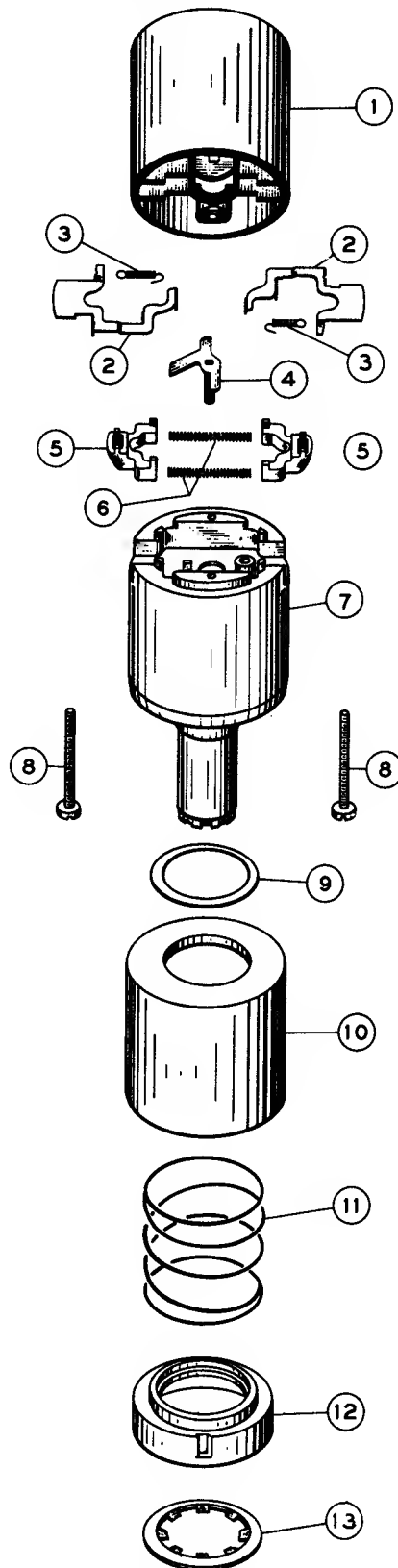

Figure 8—45 r.p.m. Centerpost

MANUAL OF 1954 MOST-OFTEN-NEEDED RADIO DIAGRAMS

RCA Victor Record Changer RP-197-1 (continued)

REPLACEMENT PARTS

ILL. NO.	STOCK NO.	DESCRIPTION
		MOTOR ASSEMBLY Stamped: 938784-1 190
1	76750	Wheel—Idler wheel
2	75433	Washer—Thrust washer
3	76744	Retainer—Hairpin spring retainer for idler wheel
4	78645	Plate—Idler wheel support plate
5	78646	Retainer—Hairpin spring retainer for idler wheel support
6	78647	Washer—Flat metal washer for idler wheel support
7	78648	Link—Idler wheel support link
8	78764	Spacer—Idler support spacer
9	78374	Spring—Idler support spring
10	76751	Grommet—Rubber grommet for motor mounting
11	76749	Spring—Spring pulley for motor shaft
12	78678	Motor—Motor assembly—LESS speed shift lever grommet
13	30870	Plug—Male, 2 contact motor plug
14	76755	Spring—Detent spring
15	77134	Collar—Speed shift lever mounting collar (nut)
16	79190	Plate—Motor mounting plate assembly includes: Ill. 4 to 9
17	Lockwasher—For speed shift lever mounting plate
18	79189	Lever—Speed shift lever
19	33139	Grommet—Speed shift lever grommet
20	79188	Plate—Speed pulley mounting plate with three pulleys
20A	76748	Pulley—33½ r.p.m. drive pulley
20B	76747	Pulley—45 r.p.m. drive pulley
20C	76746	Pulley—78 r.p.m. drive pulley
20D	75428	Washer—Felt washer for turret pulleys
20E	75427	Retainer—"C" type retainer ring for pulleys

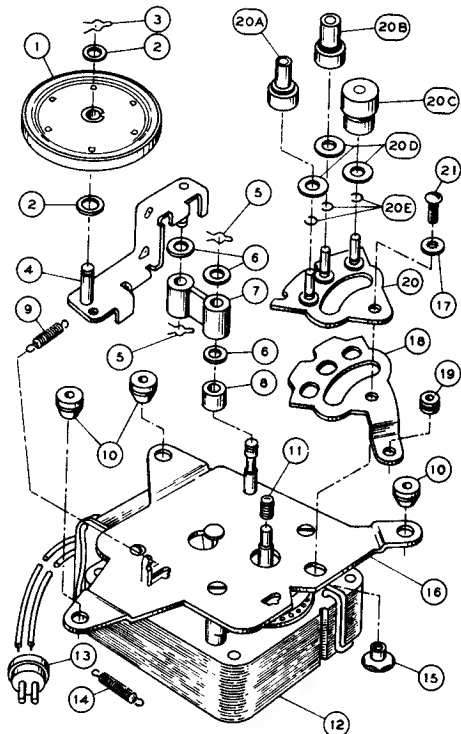

Figure 9—Motor Assembly (Stamped 938784-1 190)

ILL. NO.	STOCK NO.	DESCRIPTION
		MOTOR ASSEMBLIES Stamped: 938784-1 107
1	78508	Wheel—Idler wheel with fibre washer
2	78516	Plate—Idler plate assembly
3	78510	Washer—Felt washer
4	78509	Washer—Fibre washer
5	78511	Washer—"C" washer
6	78512	Spring—Idler spring
7	78515	Washer—Blued steel washer
8	78517	Link—Idler link
9	Screw—Holddown plate mounting screw (#6-32)
10	Lockwasher—Holddown plate mounting screw lockwasher
11	78513	Plate—Holddown plate
12	78519	Spring—Pulley latch spring
13	78518	Arm—Pulley plate latch arm
14	78514	Grommet—Motor mounting grommet
15	78520	Spring—Shifter latch spring
16	78521	Lever—Latch arm lever
17	78522	Sleeve—Sleeve pulley for 60 cycle operation
17	78523	Sleeve—Spring pulley for 50 cycle operation
18	78524	Plate—Speed pulley mounting plate—less pulleys
18A	78525	Pulley—33½ r.p.m. pulley
18B	78526	Pulley—45 r.p.m. pulley
18C	78527	Pulley—78 r.p.m. pulley
18D	78528	Washer—Speed pulley fibre washer
19	Washer—Flat metal washer
20	33139	Grommet—Speed shift lever grommet
21	78529	Lever—Speed shift lever
22	30870	Plug—2 prong male plug
	79361	Motor—Motor assembly COMPLETE— with mounting grommets—LESS Items 20 and 22—for 115 volts, 60 cycles.

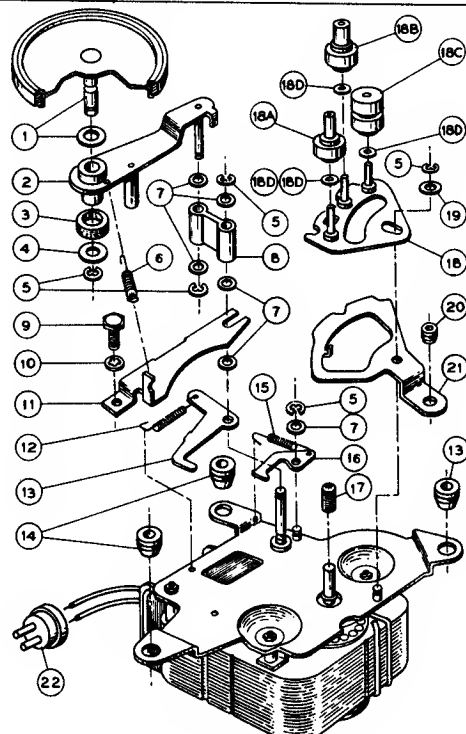

Figure 10—Motor Assembly (Stamped 938784-1 107)

MANUAL OF 1954 MOST-OFTEN-NEEDED RADIO DIAGRAMS

RCA Victor Record Changer RP-197-1 (Continued)

REPLACEMENT PARTS

ILL. NO.	STOCK NO.	DESCRIPTION
PICKUP & ARM ASSEMBLY		
1	79243	Arm—Pickup arm shell only
2	78731	Bracket—Pickup mounting bracket
3	79244	Spring—Pickup mounting bracket spring
4		Washer—Flat metal washer
5	78730	Knob—Stylus selector knob—less screw
5A	79359	Screw—#1-72 x 1/4" round head for stylus selector knob
6	77779	Pickup—Crystal pickup complete with two styli
7	74410	Screw—Pickup mounting screw—fillister head #4-40 x 3/16"
8	78733	Cable—Pickup cable assembly (3 wire) complete with terminals
9		Bracket—Bracket for pickup cable
10	71095	Nut—Speed nut to hold cable

ILL. NO.	STOCK NO.	DESCRIPTION
11	78741	Pivot—Brass bearing for pickup arm pivot
12	78742	Shaft—Pivot shaft
13	78738	Spring—Spring for height adjustment screw
14	78740	Screw—Hex head #6-32 height adjustment screw
15	78737	Spring—Counterbalance spring
16	78734	Bracket—Mounting bracket for pickup arm
17	78739	Spring—Landing adjustment screw spring
18	78732	Collar—Pickup arm mounting collar—less screw
18A	79245	Screw—Set screw for pickup arm collar
19	78728	Screw—Landing adjustment screw—R.H. #6-32 x 3/16"

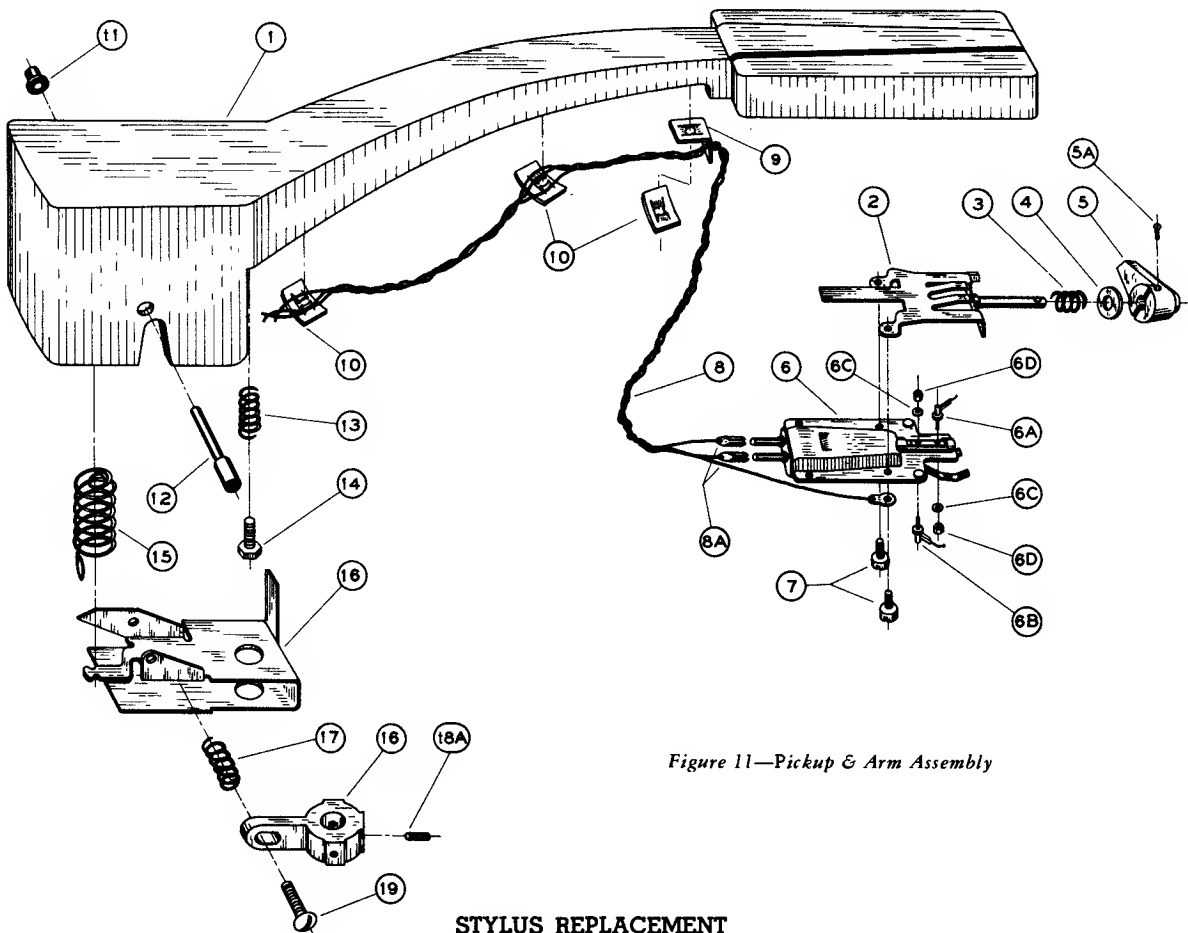

Figure 11—Pickup & Arm Assembly

STYLUS REPLACEMENT

The styli are held in position by small hex nuts (one for each stylus). Remove the nut and push threaded end of stylus through the cartridge.

Although the 78 and the 45-33 1/2 styli are mechanically interchangeable, they should be replaced in such manner that the stylus which is coded red will contact the record when

"33-45" on the stylus selector knob is visible from the top.

CAUTION:

The internal element of the pickups can be fractured by use of excessive force. It is advisable to grip stylus with pliers instead of holding pickup case while removing nuts.

MANUAL OF 1954 MOST-OFTEN-NEEDED RADIO DIAGRAMS

Sears, Roebuck and Co. Chassis 757.130
Catalog No. Sets 3004, 3005, 3006

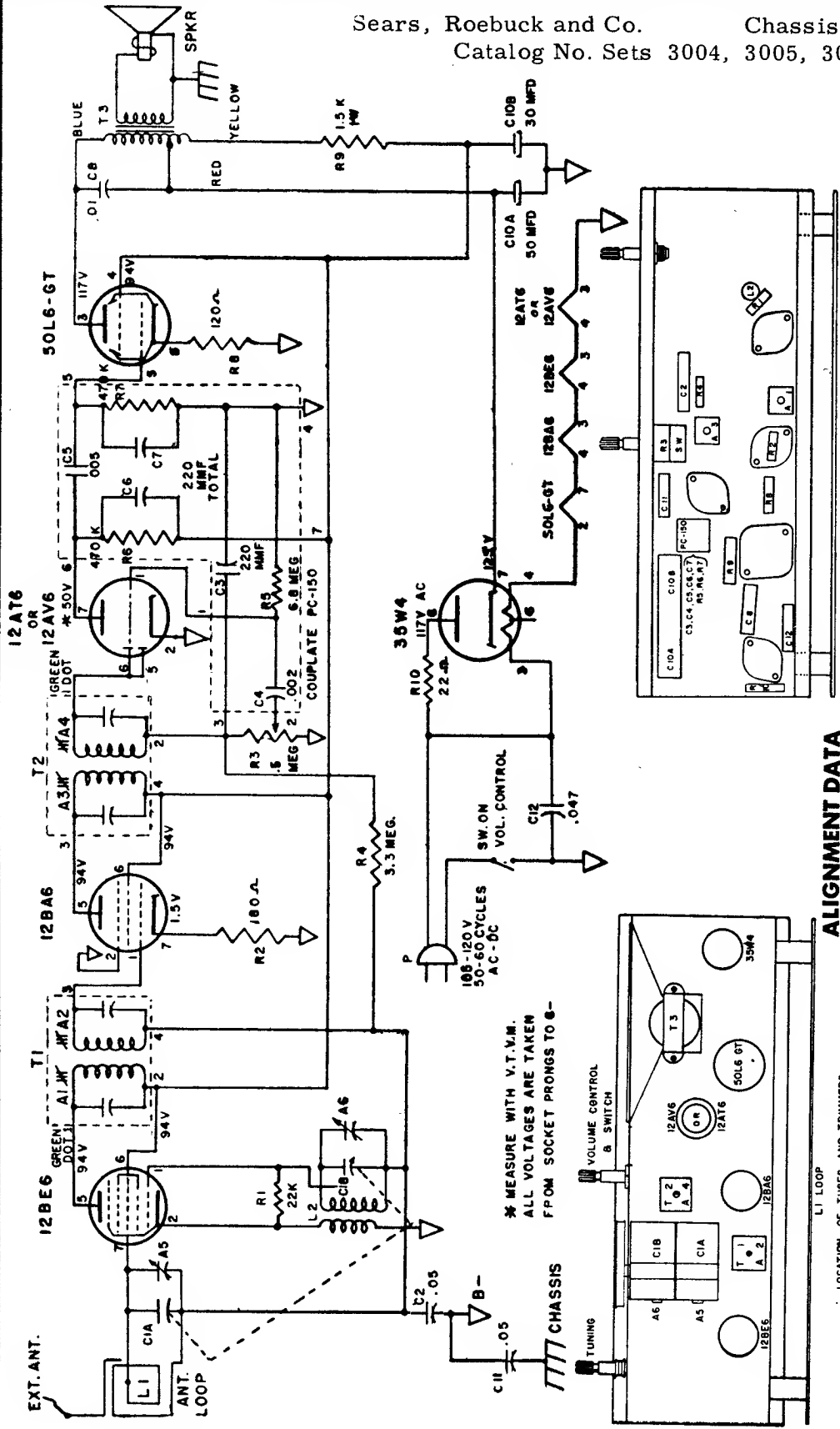

ALIGNMENT DATA

Position of Variable	Generator Frequency	Dummy Ant.	Generator Connection (high)	Generator Connection (low)	Adjust Trimmers (in order shown)	Trimmer Function
Open	455 Kc	.05 mfd	Mixed Grid	Float Gnd.	A4, A3, A2, A1	I.F.
Open (Fully)	1640 Kc	50 mmf	*	Float Gnd.	A6	Osc.
1400 Kc	1400 Kc	50 mmf	*	Float Gnd.	A5	Ant.
1000 Kc	1000 Kc	50 mmf	*	Float Gnd.	Check Point	
600 Kc	600 Kc	50 mmf	*	Float Gnd.	Check Point	

* A loop fashioned of several turns of wire radiating the signal into receiver's antenna or through the external antenna connection.

MANUAL OF 1954 MOST-OFTEN-NEEDED RADIO

Silvertone

Sears, Roebuck and Co.
Chassis 757.120
Catalog No. Sets
3007, 3008, 3009

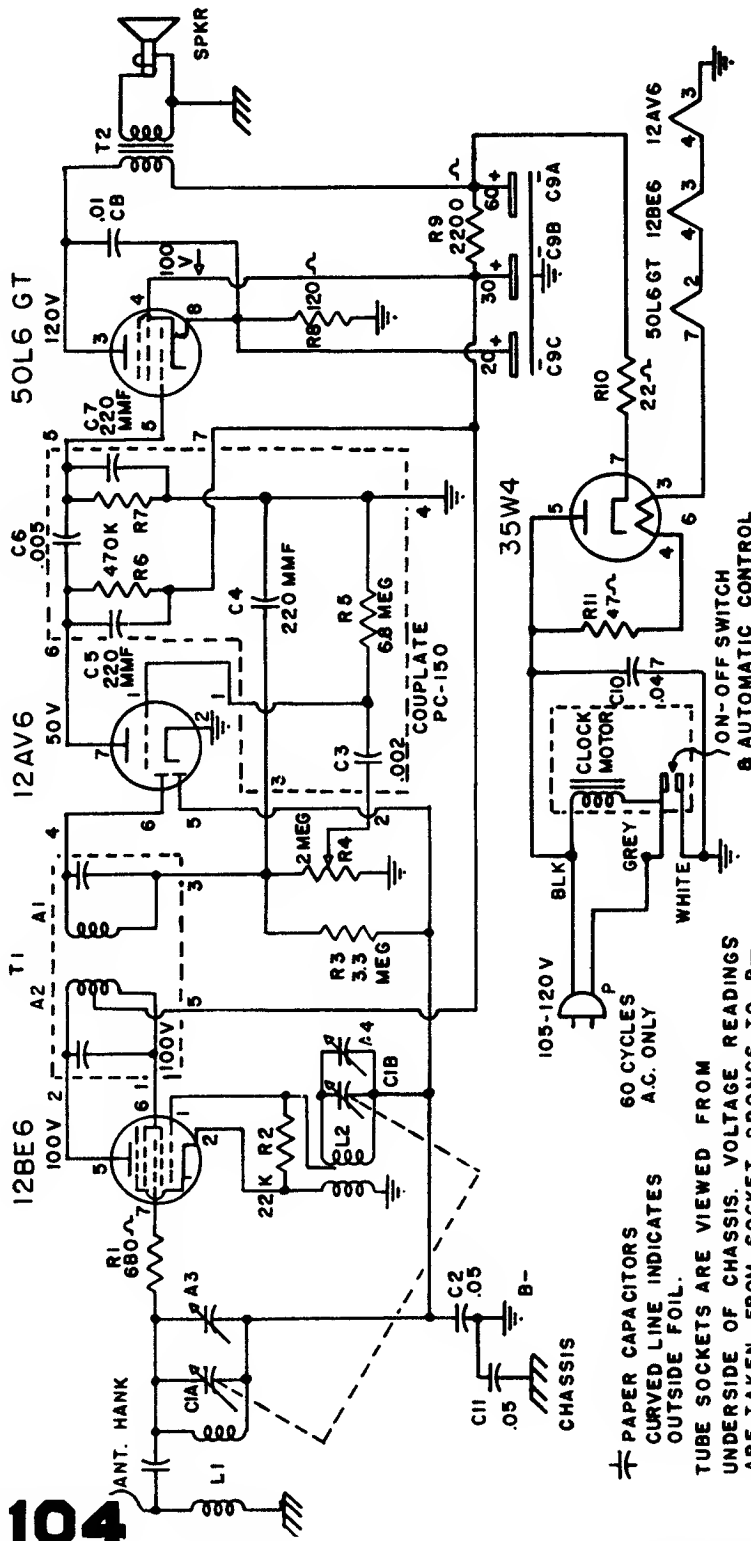

PAPER CAPACITORS
CURVED LINE INDICATES
OUTSIDE FOIL.

**TUBE SOCKETS ARE VIEWED FROM
UNDERSIDE OF CHASSIS. VOLTAGE READINGS
ARE TAKEN FROM SOCKET PRONGS TO B-,
WITH NO SIGNAL. LINE VOLTAGE AT 117V.A.C.
MEASURED WITH V.T.V.M.**

ALIGNMENT DATA

Tuning range 535 Kc. to 1640 Kc. Intermediate Frequency - 455 Kc. - I-f and R-f measurements made at 0.05 watt output - approximately 0.4 volts on a rectifier type voltmeter connected across the voice coil. Approximate inputs for 0.05 watt output: Dummy load I-f - .05 ufd; R-f - 50 ufd. I-f 2000 uv; R-f at 1400 Kc. 200 uv; at 1000 Kc. 310 uv; at 600 Kc. 510 uv.

Position of Variable	Generator Frequency	Dummy Ant.	Generator Connection (high)	Generator Connection (low)	Adjust Trimmers (in order shown)	Trimmer Function
Open	455 Kc.	.05 ufd.	Stator (CIA)	Float.Gnd.	A1, A2,	I.F.
Open	1640 Kc.	50 ufd.	*	Float.Gnd.	A4	Osc.
**1400 Kc.	1400 Kc.	50 ufd.	*	Float.Gnd.	A3	Ant.
1000 Kc.	1000 Kc.	50 ufd.	*	Float.Gnd.	Check point	
600 Kc.	600 Kc.	50 ufd.	*	Float.Gnd.	Check point	

*Disconnect antenna hank from ant. coil and connect 50 ufd. dummy antenna load to ant. coil.
**Balance at 1400 Kc. by rocking variable condenser while adjusting antenna trimmer (A3) for maximum output.

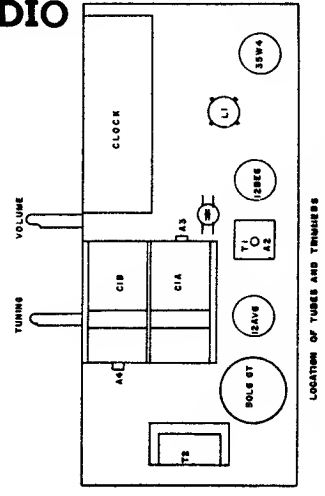

MANUAL OF 1954 MOST-OFTEN-NEEDED RADIO DIAGRAMS

Silvertone

Sears, Roebuck and Co.

Chassis 528.253, Catalog No. 3040

Chassis 528.254, Catalog No. Sets

3045 and 3046 are almost identical.

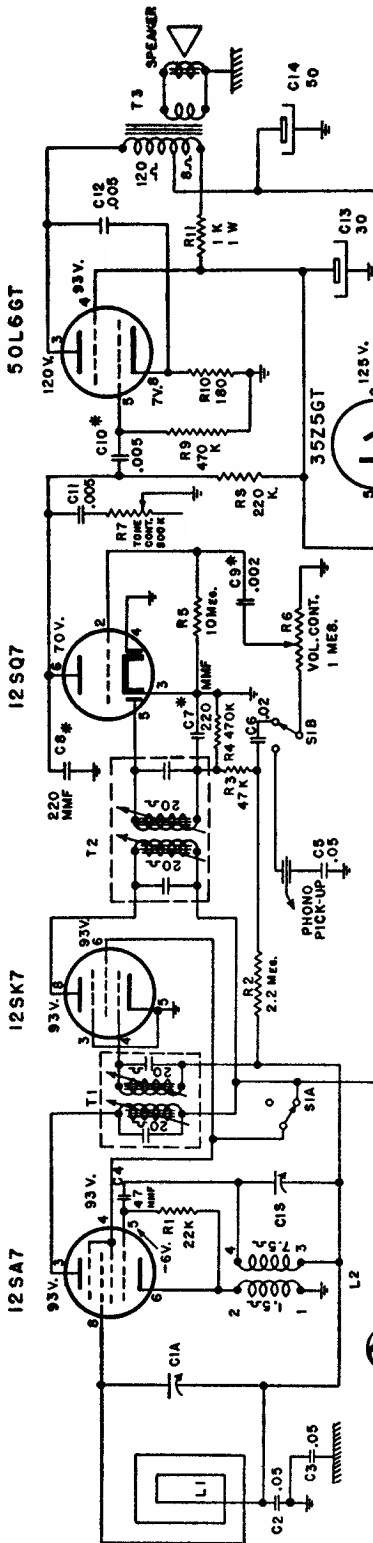

NOTES- OSCILLATOR COIL
VALUES OF CAPACITORS IN MFD.
UNLESS OTHERWISE SPECIFIED.
ALL RESISTORS 1/2 WATT UNLESS
OTHERWISE SPECIFIED.
* THESE CAPACITORS ARE IN CERAMIC
UNIT PART NO. T17-104.

VOLTAGES MEASURED FROM POINT INDICATED
TO COMMON GROUND WITH 20,000 OHM/VOLT
VOLTMETER. RADIO-PHONO SWITCH IN RADIO
POSITION, LINE VOLTAGE SET AT 117 V. AC.

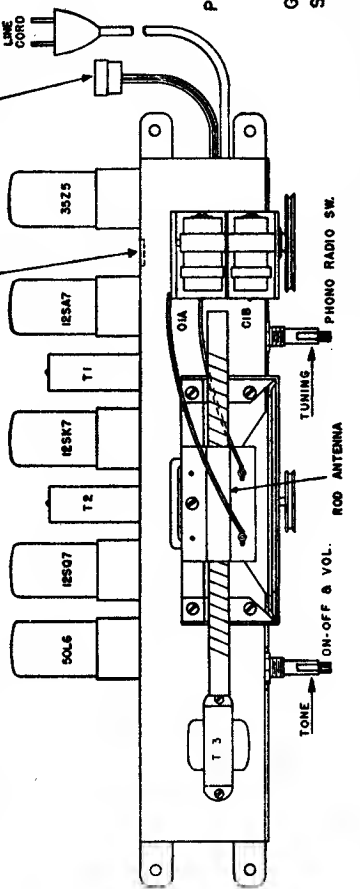
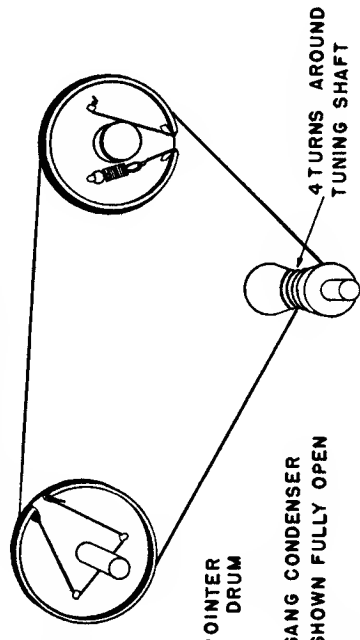
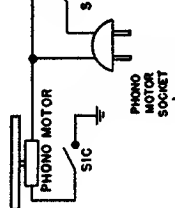

ALIGNMENT PROCEDURE

POSITION OF TUNER	GENERATOR FREQUENCY	DUMMY ANTENNA	GENERATOR CONNECTION	TRIMMER ADJUSTMENT	TRIMMER FUNCTION
open	455 KC	.1 mfd.	pin 8 12SA7	T1 and T2 top and bottom	I.F.
open	1630 KC	.1 mfd.	pin 8 12SA7	C1B	Oscillator
1400 KC	1400 KC	HAZELTINE TEST LOOP		C1A	Antenna

MANUAL OF 1954 MOST-OFTEN-NEEDED RADIO

Silvertone

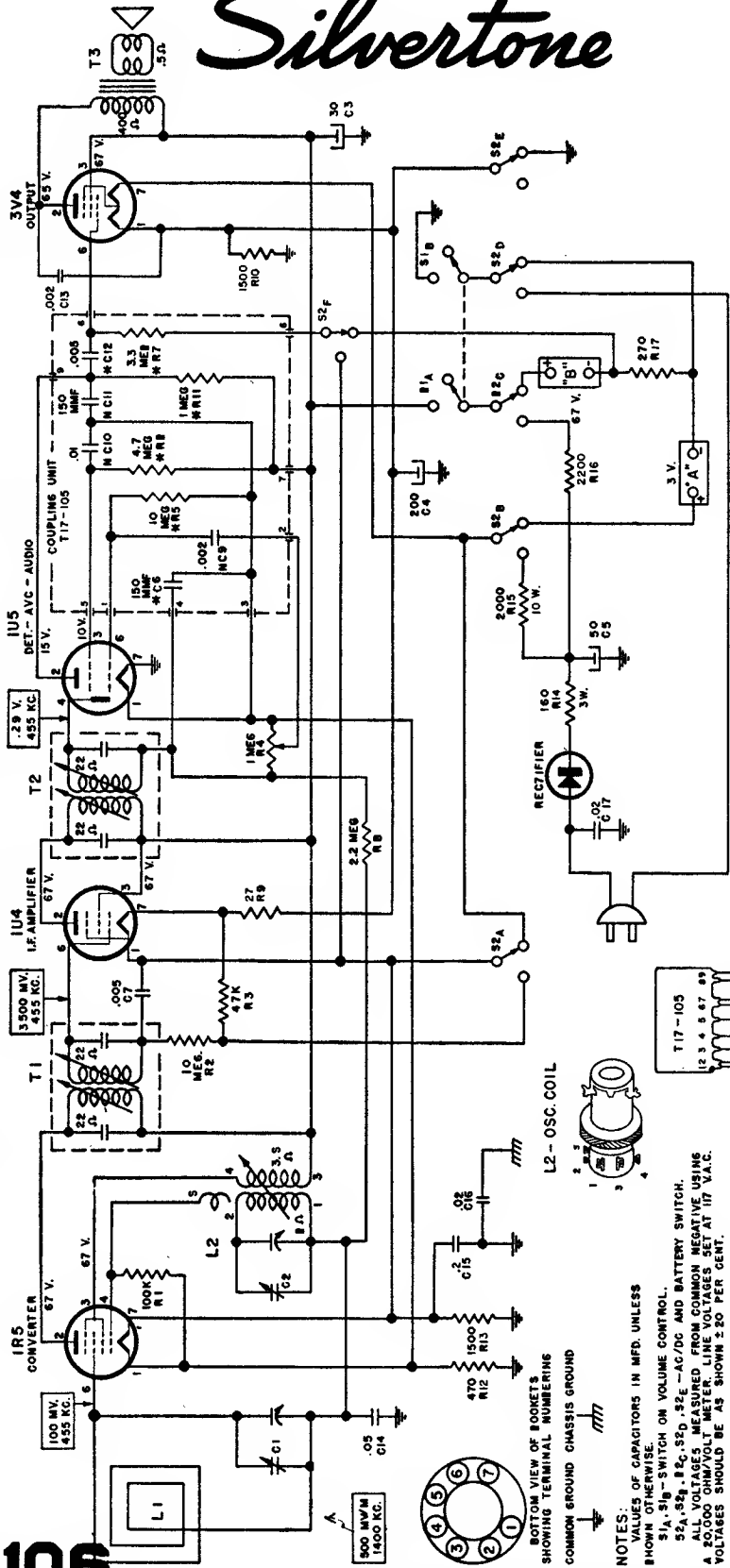

ALIGNMENT PROCEDURE

Position of Tuner	Generator Freq.	Dummy Antenna	Generator Connection	Adjustments to be made (in order shown) for max. output	Function	Max. Microvolts Input to produce .05 w. output
Min. Cap.	455 kc	0.1 mfd.	Pin #6 of 1U4 I-F Amp.	T2 (top and bottom)	I.F.	5000
Min. Cap.	455 kc	0.1 mfd.	Pin #6 of IR5 Conv.	T1 (top and bottom)	I.F.	250
Min. Cap.	1625 kc	0.1 mfd.	Stator ant. tuner	C2	Oscillator	
1400 kc	1400 kc		Hazeltine Test Loop	C1	Loop	*9000 uV
600 kc	600 kc		Hazeltine Test Loop	L2	Oscillator	9000 uV

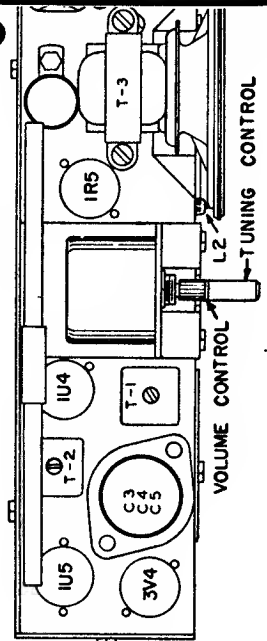

Sears, Roebuck and Co.
 Chassis 528.265
 Catalog No. Sets
 3215, 3217, 3218

(Rock variable condenser back and forth thru the signal while adjusting core in oscillator coil L2.)
 *Signal generator output into Hazeltine Test Loop placed 24 inches from end of rod antenna.

MANUAL OF 1954 MOST-OFTEN-NEEDED RADIO DIAGRAMS

Sentinel

MODELS 352-1U-352

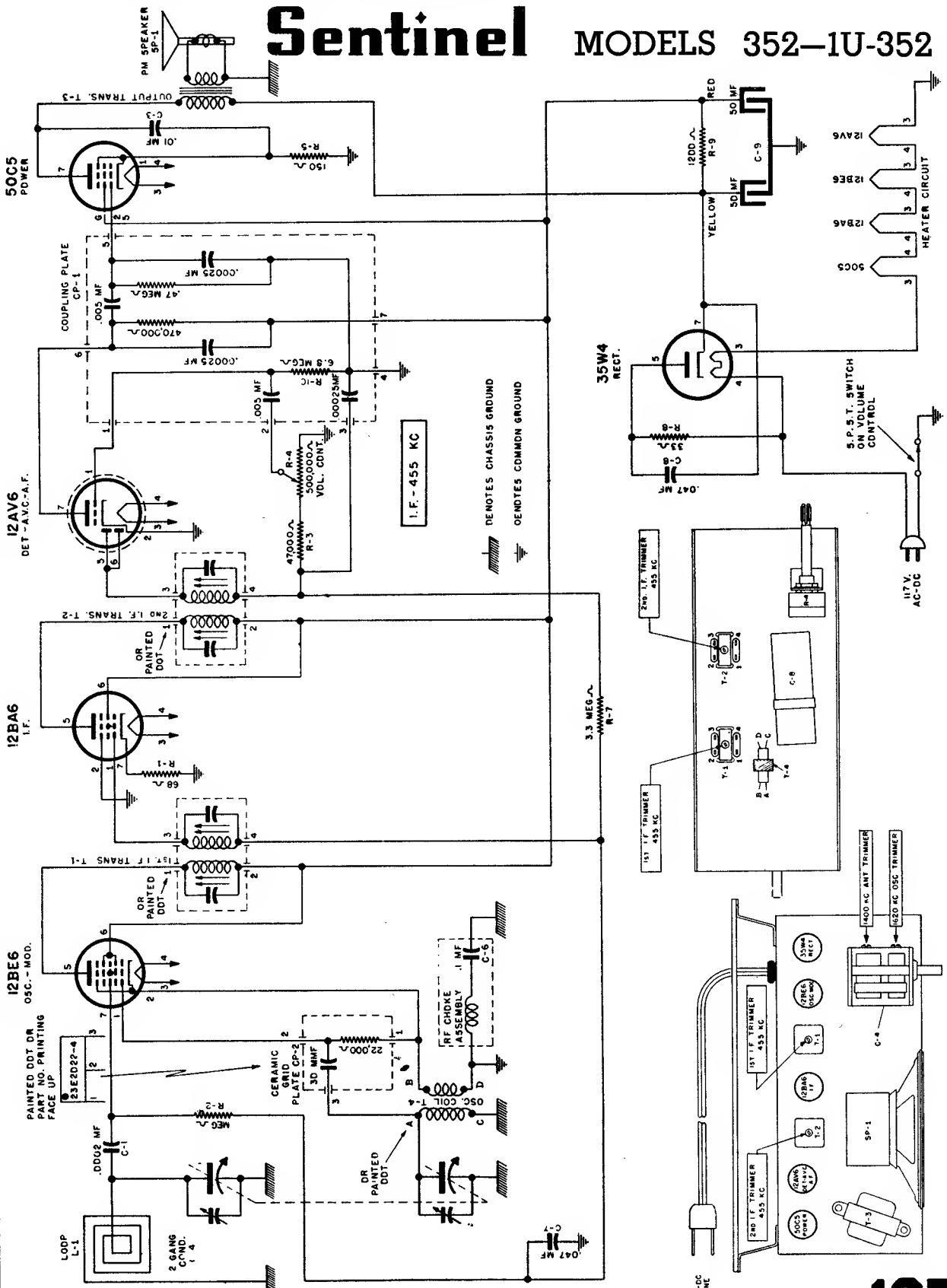

MANUAL OF 1954 MOST-OFTEN-NEEDED RADIO DIAGRAMS

Sentinel Radio

MODEL
1U-354P

GREEN
IVORY
EBONY
MAHOGANY

TAN
RED
RUST
MAHOGANY

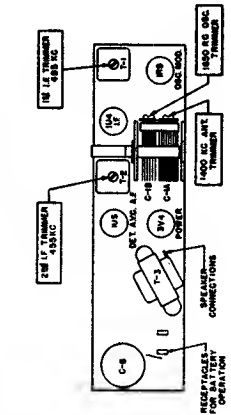
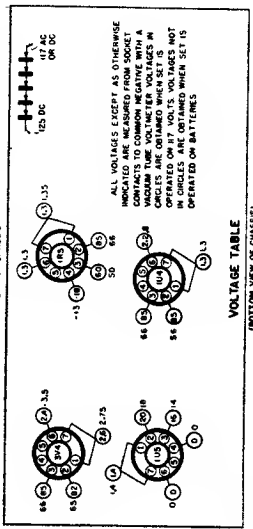
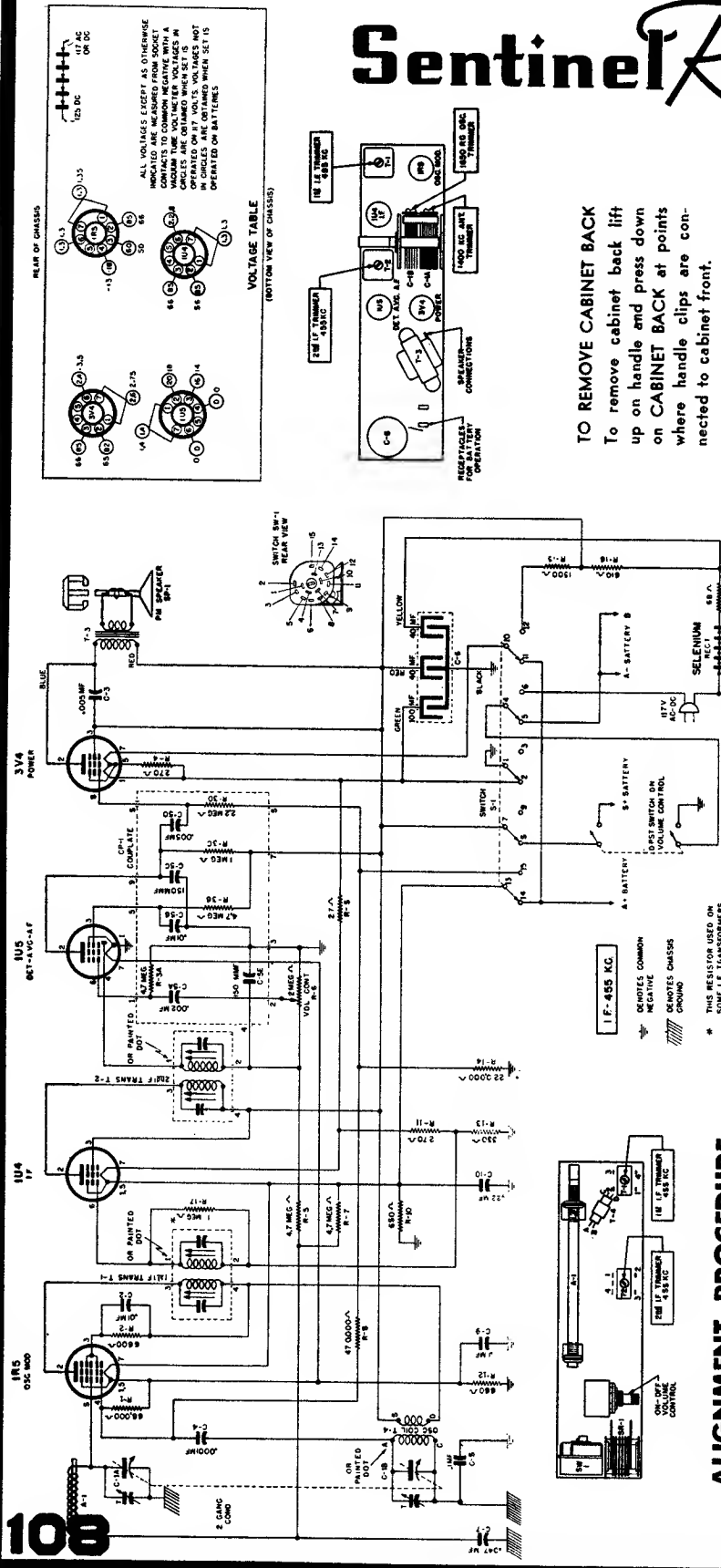

TO REMOVE CABINET BACK
To remove cabinet back lift up on handle and press down on CABINET BACK at points where handle clips are connected to cabinet front.

ALIGNMENT PROCEDURE
TO ALIGN 1650 KC OSCILLATOR AND 1400 KC ANTENNA TRIMMERS: Couple test oscillator to receiver by; (1) make loop consisting of five turns of No. 20 to 30 size wire, wound on a 2" or 3" form; (2) connect this loop across output of test oscillator; (3) place test oscillator loop near radio antenna. BE SURE THAT NEITHER LOOP OR RADIO MOVES WHILE ALIGNING.

TEST OSCILLATOR		Refer to parts layout diagram for location of trimmers mentioned below:	
Steps	Set receiver dial to:	Adjust test oscillator frequency to:	Attach output of test oscillator to
1	Any point where no interfering signal is received	Exactly 455 K. C.	High side to pin 6 grid of 1R5 tube. Low side to common negative through a .02 MFD blocking condenser.
2	Rotate gang condenser to minimum capacity	Exactly 1650 K. C.	See Alignment Procedure above
3	Approximately 1400 K. C.	Approx. 1400 K. C.	Adjust 1650 K. C. oscillator trimmer for maximum output. Adjust 1400 K. C. antenna trimmer for maximum output.

MANUAL OF 1954 MOST-OFTEN-NEEDED RADIO DIAGRAMS

Sentinel MODEL 1U-355P

Illus. No.	Part No.	DESCRIPTION
CAPACITORS		
C-1A)	24E63	Variable (2 Gang)
C-1B)		
C-2	23E4004-17	Ceramic Fixed, .01 MFD
C-3	23E4004-15	Ceramic Fixed, .005 MFD
C-4A)	23E2024	Ceramic Capacitor Plate
C-4B)		
C-4C)		
C-4D)		
C-5	23E4000-17	Ceramic Fixed, .0001 MFD
C-6	23E3214	Molded Tubular, .047 MFD, 200 V.
C-7	23E2043-9	Tubular Midget, .1 MFD, 200 V.
C-8	23E2043-9	Tubular Midget, .1 MFD, 200 V.
C-9	23E4000-17	Ceramic Fixed, .0001 MFD.
C-10	25E75	Dry Electrolytic, 40-40 MFD, 150 V., 100 MFD, 10 V.
C-11	23E3416	Molded Tubular, .1 MFD, 400 V.
C-12	23E3414	Molded Tubular, .047 MFD, 400 V.
C-13	23E3214	Molded Tubular, .047 MFD, 200 V.

R-1	27E683K-1/2
R-2	27E682K-1/2
R-3	27E475M-1/2
R-4	27E475M-1/2
R-5	27E105M-1/2
R-6	27E225M-1/2
R-7	27E475M-1/2
R-8	28E83
R-9	27E474M-1/2
R-10	27E475M-1/2
R-11	27E271K-1/2
R-12	27E471K-1/2
R-13	27E331K-1/2
R-14	27E154M-1/2
R-15	27E330K-1/2
R-16A)	27E1020
R-16B)	
R-17	27E680K-1
R-18	27E105M-1/2
R-19	27E104M-1/2

RESISTORS

Carbon, 68,000 Ohm ± 10% 1/2 W
Carbon, 6,800 Ohm ± 10% 1/2 W
Carbon, 4.7 Megohm ± 20% 1/2 W
Carbon, 4.7 Megohm ± 20% 1/2 W
Carbon, 1 Megohm ± 20% 1/2 W
Carbon, 2.2 Megohm ± 20% 1/2 W
Carbon, 4.7 Megohm ± 20% 1/2 W
Control, Volume 2 Megohm with D.P.S.T.
Carbon, 470,000 Ohm ± 20% 1/2 W
Carbon, 4.7 Megohm ± 20% 1/2 W
Carbon, 270 Ohm ± 10% 1/2 W.
Carbon, 470 Ohm ± 10% 1/2 W.
Carbon, 330 Ohm ± 10% 1/2 W.
Carbon, 150,000 Ohm ± 20% 1/2 W.
Carbon, 33 Ohm ± 10% 1/2 W.
Wirewound, 1550 Ohm, 4 W., 610 Ohm
Carbon, 68 Ohm, 1 W.
Carbon, 1 Megohm ± 20% 1/2 W.
Carbon, 100,000 Ohm ± 20% 1/2 W

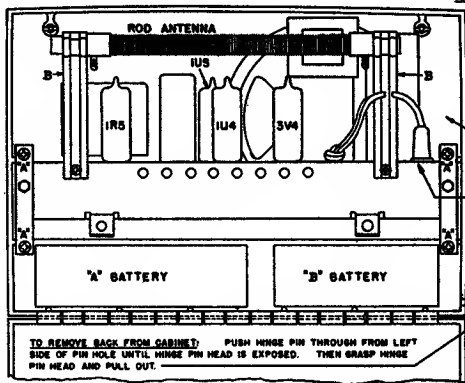

TO REMOVE CHASSIS FROM CABINET

1. Remove Dial Indicator and Volume Knob from Side of Cabinet.
2. Disconnect Battery Leads and Remove Batteries.
3. Lay Cabinet Face Down and Remove the Four Screws Marked "A."

WIND EXCESS LINE CORD AND PLACE IN THIS SPACE.

FOR BATTERY OPERATION THE AC-DC LINE CORD PLUG MUST BE FIRMLY INSERTED IN THIS RECEPTACLE.

FOR AC-DC OPERATION PLACE LINE CORD IN NOTCH AND CLOSE BACK.

TO REMOVE BACK FROM CABINET: PUSH NIBBLE PIN THROUGH FROM LEFT SIDE OF PIN HOLE UNTIL NIBBLE PIN HEAD IS EXPOSED. THEN GRASP NIBBLE PIN HEAD AND PULL OUT.

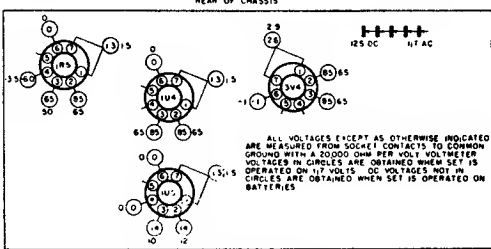
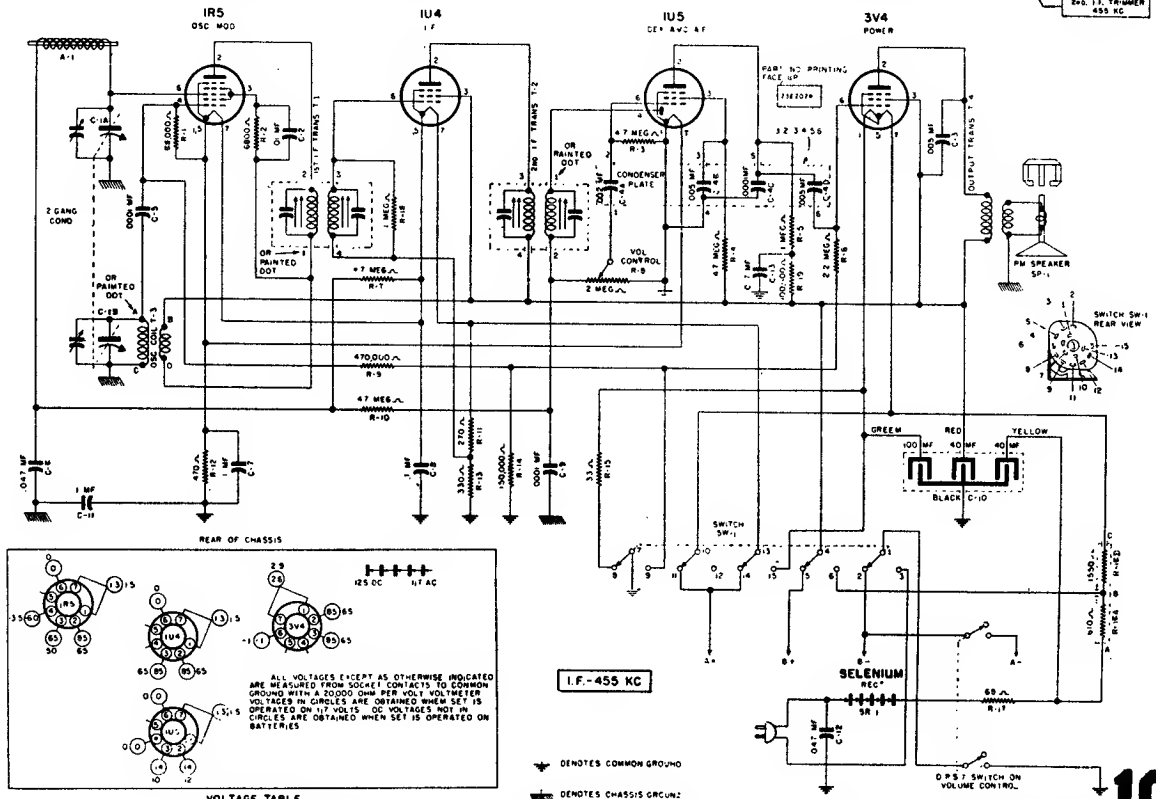
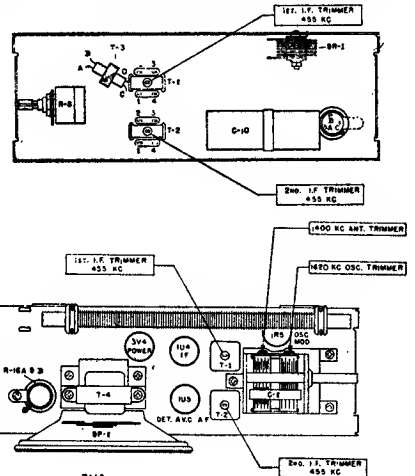

⚡ DENOTES COMMON GROUND
 ⚡ DENOTES CHASSIS GROUND

Sentinel Radio

356-1U-356

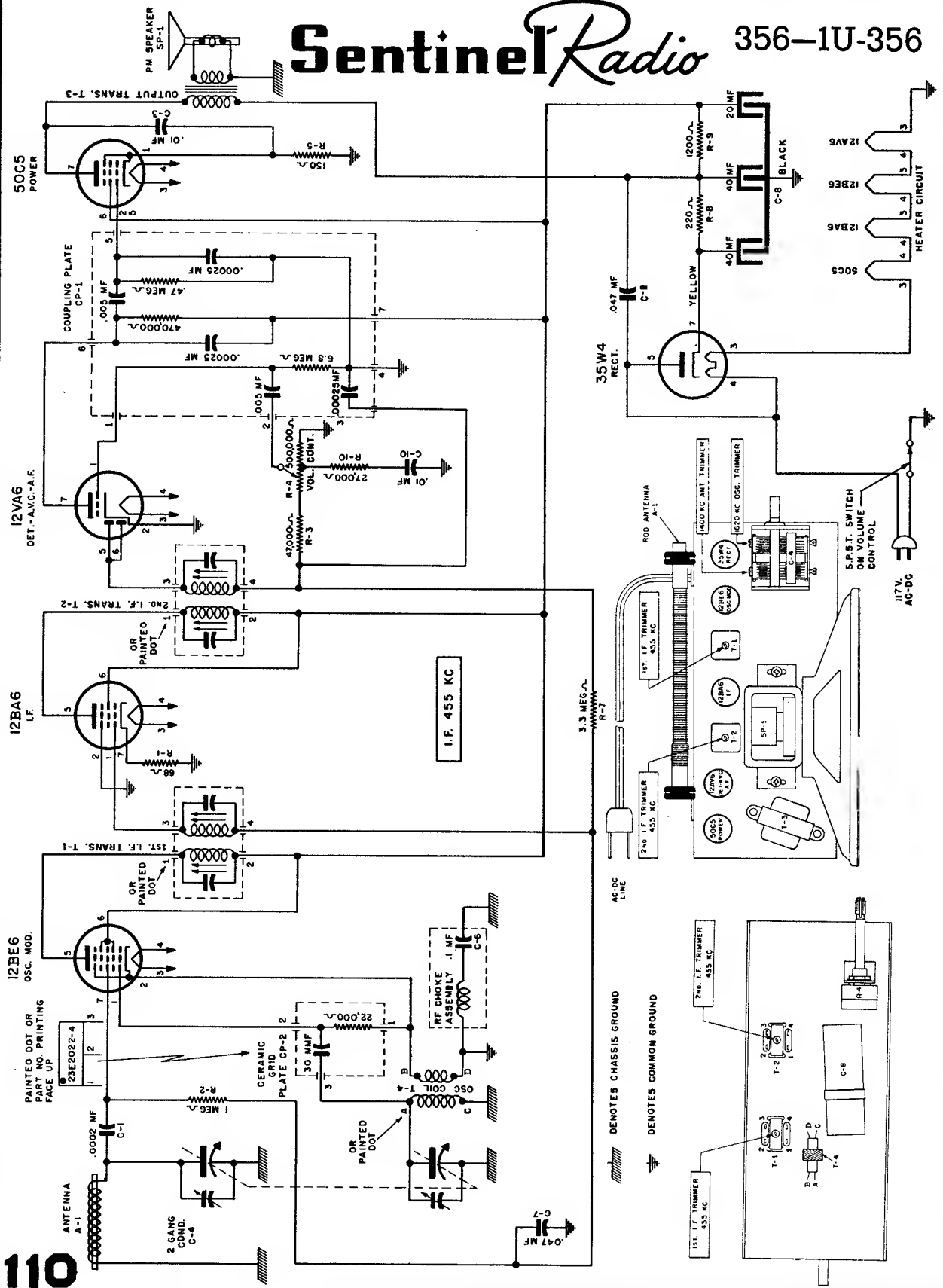

MANUAL OF 1954 MOST-OFTEN-NEEDED RADIO DIAGRAMS

SPARTON MODEL 5A3 & 5A3C

Chassis types 5A3 and 5A3C are used in Models 311C, 312C, 315C, and 319C. Chassis 5A10 used in Models 230, 232, 239, use practically the identical circuit, but do not employ a clock.

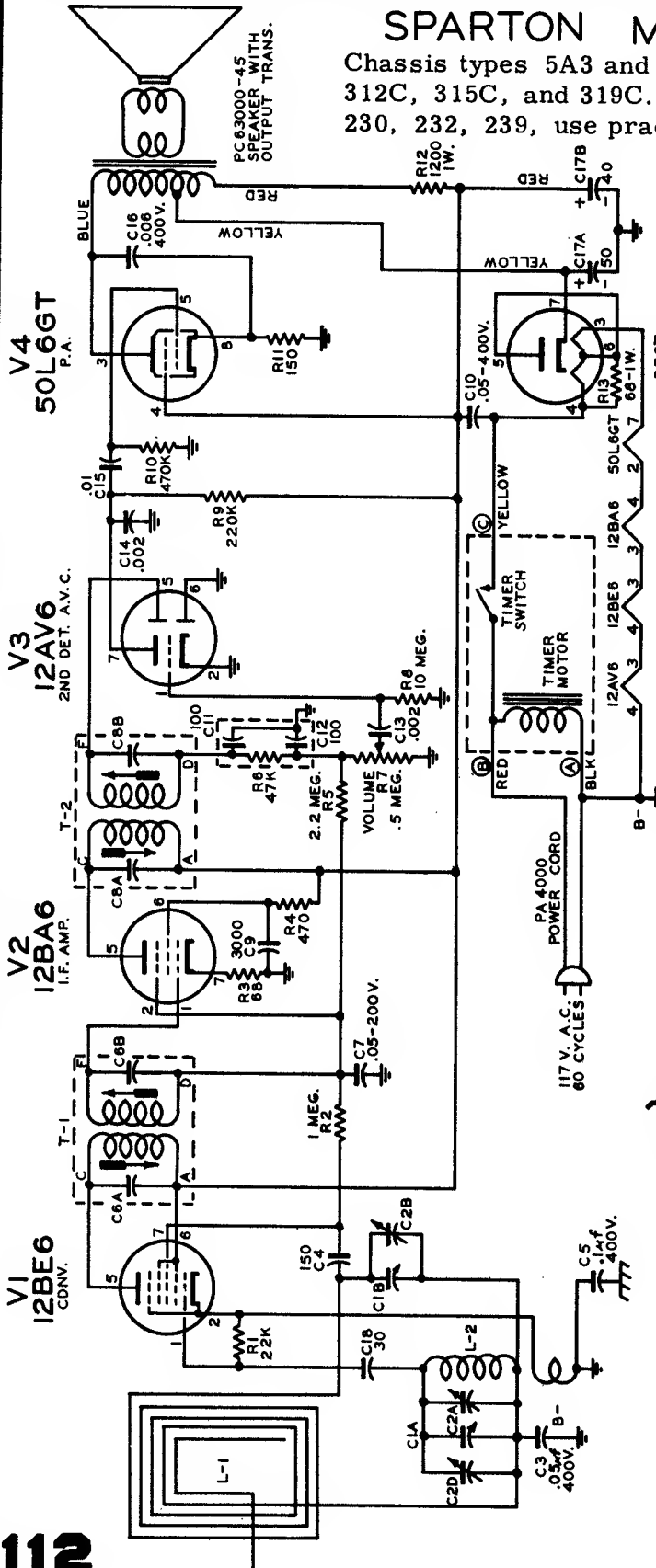

INDICATES CONNECTION TO B-BUSS, NOT CHASSIS.
 INDICATES CHASSIS CONNECTION.
 * SPECIAL SERVICE NOTE: THESE TRANSFORMERS SUPPLIED IN COMPLETE ASSEMBLIES ONLY.

DESCRIPTION	PART NO.
C1A TUNING CONDENSER	PB40414
C2A B.T. TRANSFORMER	PC40CL-503
C3 .05 MFD. 400V. TUBULAR	CC30G-152
C4 .150 MFD. CERAMIC	PC40FL-104
C5 .1 MFD. 400V. TUBULAR	*
C6A B.T. CAPACITORS	PC40GK-503
C7 .05 MFD. 200V. TUBULAR	HK35F-302
C8A B.T. CAPACITORS	PC40HL-503
C9 3000 MMF. CERAMIC	PA4329-1
C10 .05 MFD. 400V. TUBULAR	HK35E-202
C11 100 MMF. C&R UNIT	PC40GK-103
C12 90 MMF. CERAMIC	PC40HL-602
C13 2K MMF. CERAMIC	PA4310
C14 .002	CC30H-300K
C15 .01 MFD. 200V. TUBULAR	
C16 .008 MFD. 400V. TUBULAR	
C17A 40-50 MFD. ELECTROLYTIC	
C18 .30 MFD. CERAMIC	

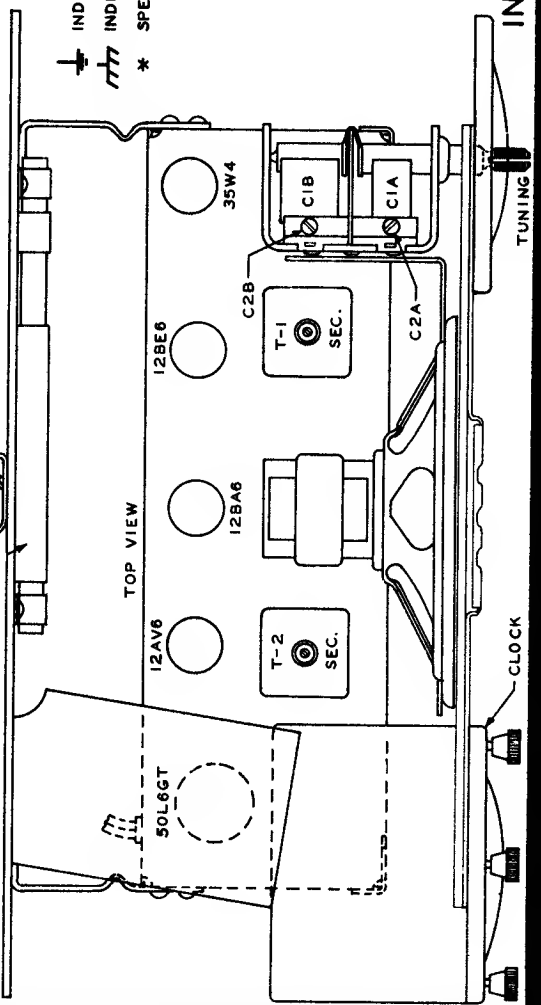

MANUAL OF 1954 MOST-OFTEN-NEEDED RADIO DIAGRAMS

STEWART-WARNER MODELS 9170-B, 9170-C, & 9170-D

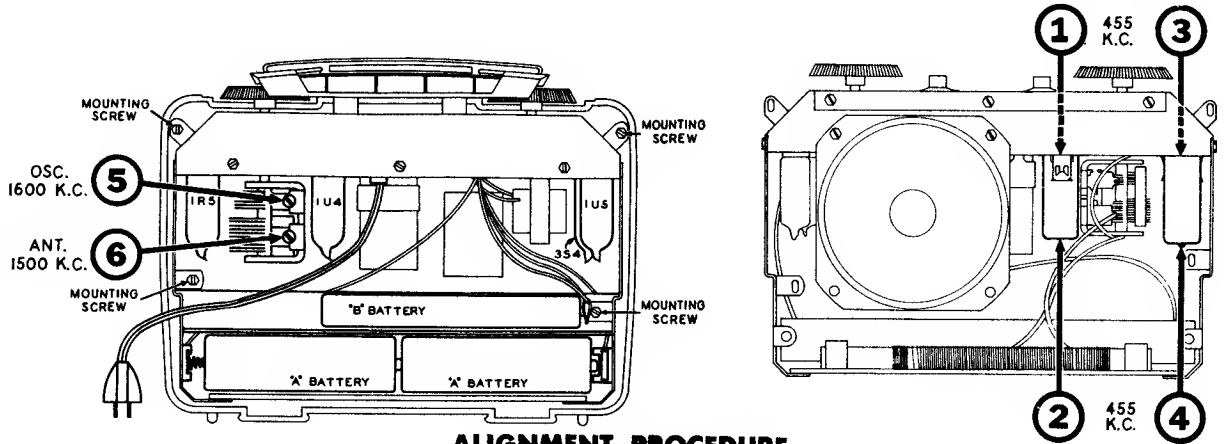

ALIGNMENT PROCEDURE

SIGNAL GENERATOR CONNECTIONS		SIGNAL GENERATOR FREQUENCY	RECEIVER DIAL SETTING	TRIMMER OR SLUG NUMBER	TRIMMER DESCRIPTION	TYPE OF ADJUSTMENT
CONNECT HIGH SIDE OF SIGNAL GENERATOR TO	CONNECT GROUND LEAD OF SIGNAL GENERATOR TO					
Lug on trimmer #6 at side of gang (see chart below for location of trimmer).	Any B— terminal in chassis.	455 KC	Any point where it does not affect the signal.	1 and 2	2nd I.F.	Adjust for maximum output. Then repeat adjustment.
				3 and 4	1st I.F.	
<p>IMPORTANT: Before undertaking alignment of the oscillator and antenna trimmers it is necessary to reassemble the chassis in the cabinet. The tuning knob should be installed on the gang condenser shaft so that when the condenser is fully meshed, the dot under the smaller 5 of the 55 on dial scale is directly opposite the pointer (gold mark on cabinet). As battery position slightly affects R.F. alignment, it is preferable to have batteries in proper place. To gain access to oscillator and antenna trimmers, it will be necessary to open back of cabinet. In order to provide a coupling for the signal generator, during this part of the procedure, wind several turns of wire in a circular shape to form a radiating loop that may be placed adjacent (axes parallel) to the loop antenna. Now complete the alignment procedure as follows.</p>						
Connect directly to radiating loop. (See above for instructions on radiating loop.) Rotate and adjust loop for maximum input.		1600 KC	1600 KC	5	Broadcast Oscillator	Adjust for maximum output.
Same as above.		1500 KC	Tune to 1500 Kc. generator signal.	6	Broadcast Antenna	Adjust for maximum output.

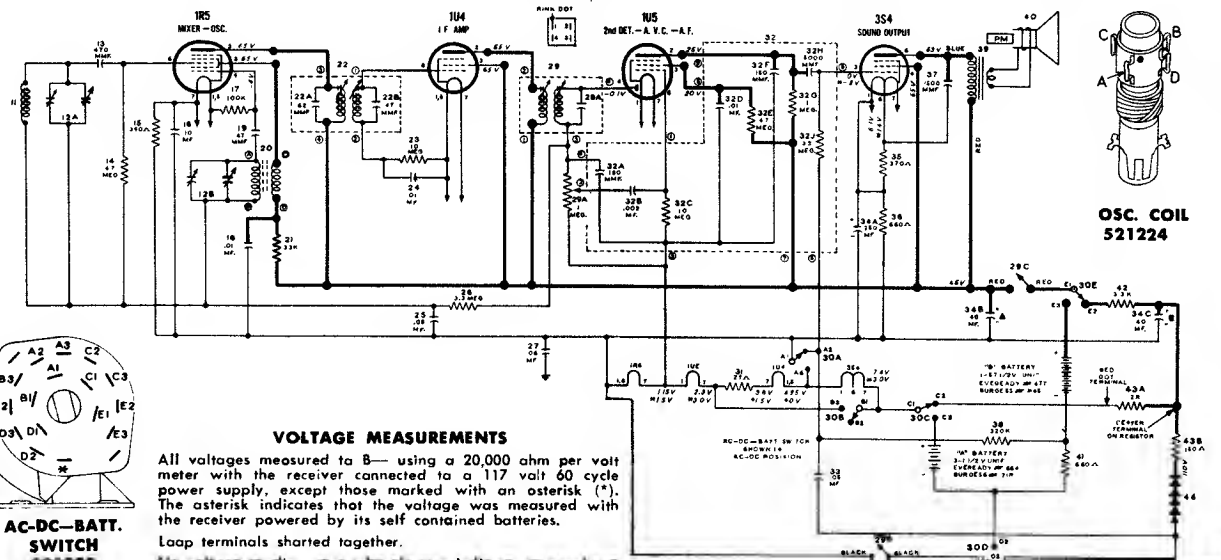

AC-DC-BATT. SWITCH 521293

*May serve as a wiring point.

MANUAL OF 1954 MOST-OFTEN-NEEDED RADIO DIAGRAMS

STEWART-WARNER MODELS 9175-B, BU, G, GU, H, & HU

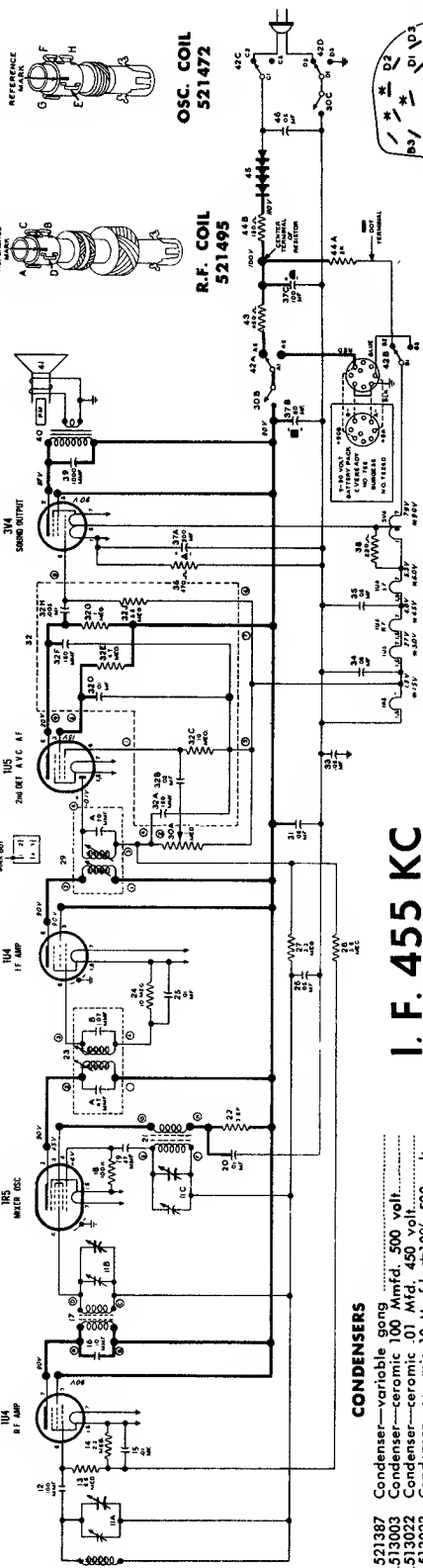

I. F. 455 KC

REMOVING CHASSIS FROM CABINET

1. Raise the carrying handle until Latch Button is exposed. Press down on the button and simply separate the back and front halves of the cabinet while holding the latch button down.
2. Disconnect back retaining card by removing center screw on receiver chassis.
3. Remove the chassis mounting screws (see Trimmer Location Chart) and lift chassis from cabinet.
4. Disengage one end of handle from escutcheon by squeezing together the wire retaining clip.
5. Remove the escutcheon by taking out the cross slotted screws.
6. Control knobs may now be removed by pulling them straight up.
7. Lift off dial plate.
8. Remove dial scale by pulling straight up.

CONDENSERS

- 11-A,B,C 521387 Condenser—variable gong
- 12 513003 Condenser—ceramic 10 Mmfd. 500 volt.
- 15 513022 Condenser—ceramic 10 Mmfd. 450 volt.
- 16 513023 Condenser—ceramic 10 Mmfd. $\pm 10\%$ 500 volt.
- 19 513002 Condenser—ceramic 47 Mmfd. 500 volt.
- 20 513002 Condenser—ceramic .01 Mfd. 450 volt.
- 23-A 509433 Condenser—ceramic 87 Mmfd. (part of 1st I.F. transformer)
- 23-B 509433 Condenser—ceramic 107 Mmfd. (part of 1st I.F. transformer)
- 25 513022 Condenser—ceramic .01 Mfd. 450 volt.
- 26 512214 Condenser—.05 Mfd. 400 volt.
- 29-A 521319 Condenser—ceramic 20 Mmfd. (part of 2nd I.F. transformer)
- 31 512214 Condenser—.05 Mfd. 400 volt.
- 32-A 521305 Condenser—ceramic 150 Mmfd. 500 volt (part of Audio Coupling Unit)
- 32-B 521305 Condenser—ceramic .002 Mfd. 500 volt (part of Audio Coupling Unit)
- 32-D 521305 Condenser—ceramic .01 Mfd. 500 volt (part of Audio Coupling Unit)
- 32-F 521305 Condenser—ceramic 150 Mmfd. 500 volt (part of Audio Coupling Unit)
- 32-H 521305 Condenser—ceramic 5000 Mmfd. 500 volt (part of Audio Coupling Unit)
- 33 512214 Condenser—.05 Mfd. 400 volt.
- 34 512214 Condenser—.05 Mfd. 400 volt.
- 35 512214 Condenser—.05 Mfd. 400 volt.
- 37-A,B,C 521484 Condenser—electrolytic
A—200 Mfd. 10 volt
B—80 Mfd. 150 volt
C—100 Mfd. 150 volt
- 39 513034 Condenser—ceramic 1000 Mmfd. 500 volt.
- 40 512214 Condenser—.05 Mfd. 400 volt.

RESISTORS

- 13 510194 Resistor—carbon 3.3 Meg. 1/2 watt
- 14 510193 Resistor—carbon 2.2 Meg. 1/2 watt
- 18 510173 Resistor—carbon 100,000 Ohms $\pm 10\%$ 1/2 watt
- 22 510173 Resistor—carbon 33,000 Ohms $\pm 10\%$ 1/2 watt
- 24 510197 Resistor—carbon 10 Meg. 1/2 watt
- 27 510193 Resistor—carbon 2.2 Meg. 1/2 watt
- 28 510786 Resistor—carbon 5.6 Meg. 1/2 watt
- 30-A,B 521234 Volume Control—1 Meg. (with On-Off switch)
- 32-C 521305 Resistor—carbon 10 Meg. 1/2 watt (part of Audio Coupling Unit)
- 32-E 521305 Resistor—carbon 4.7 Meg. 1/2 watt
- 32-G 521305 Resistor—carbon 1 Meg. 1/2 watt (part of Audio Coupling Unit)
- 32-J 521305 Resistor—carbon 3.3 Meg. 1/2 watt (part of Audio Coupling Unit)
- 36 510130 Resistor—carbon 470 Ohms $\pm 10\%$ 1/2 watt
- 38 510124 Resistor—carbon 220 Ohms $\pm 10\%$ 1/2 watt
- 43 510135 Resistor—carbon 820 Ohms $\pm 10\%$ 1/2 watt
- 44-A,B 521210 Resistor—wire wound (includes mounting bracket)
A—2000 Ohms $\pm 5\%$ 7 watt
B—150 Ohms $\pm 10\%$ 3 watt

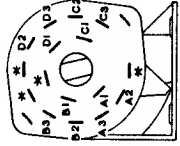

AC-DC-BATT. SWITCH 521293

*May serve as a wiring junction point.

Lettered terminals in illustrations correspond to similarly lettered terminals on the circuit diagram.

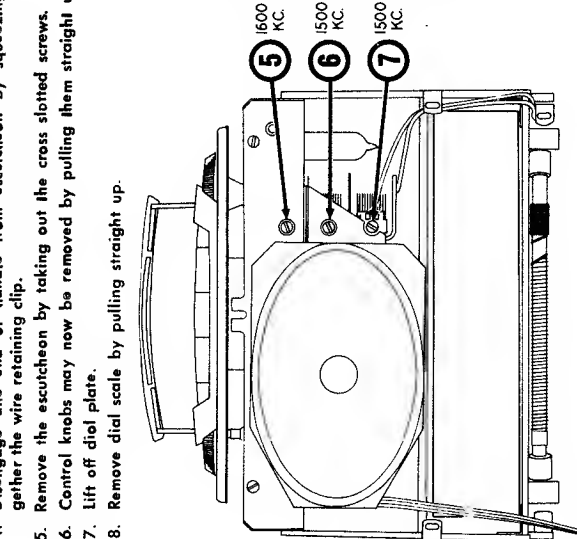
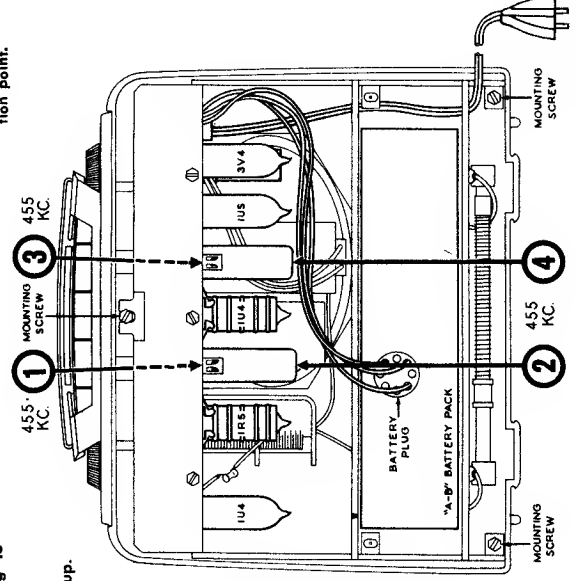

MANUAL OF 1954 MOST-OFTEN-NEEDED RADIO DIAGRAMS

STEWART-WARNER MODELS 9180-B & 9180-H

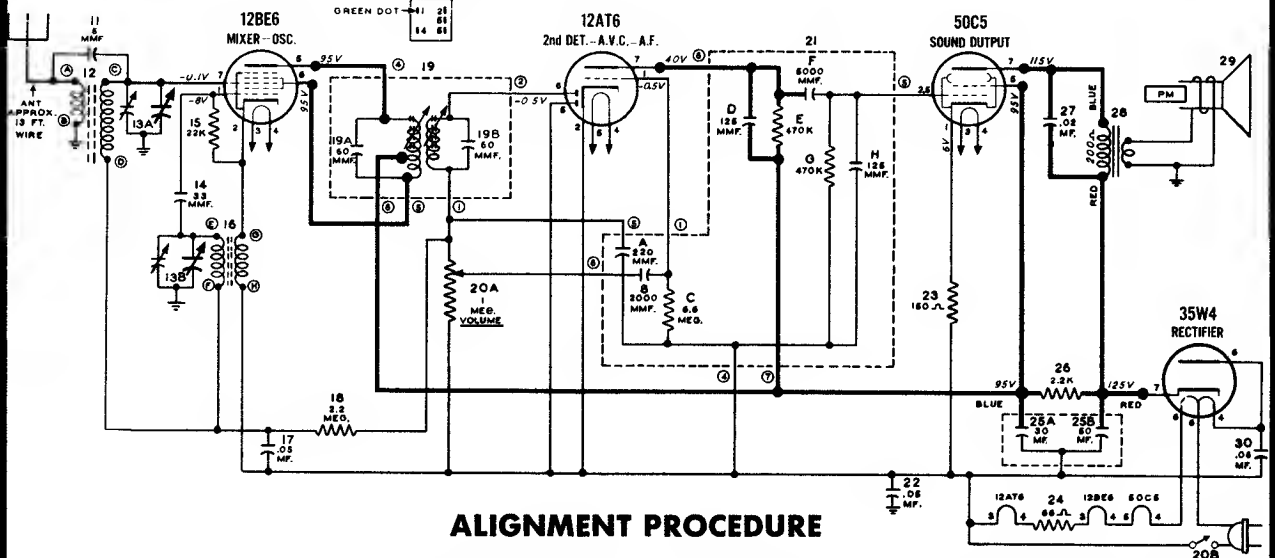

ALIGNMENT PROCEDURE

1. Remove chassis and cabinet back assembly from cabinet by pulling tuning and volume knobs straight off of their respective shafts, by prying off the two retaining clips at top of cabinet back and by removing the two chassis mounting screws at bottom outside back edge of cabinet. (NOTE: Do not disturb the other two externally mounted screws at bottom of cabinet back. These screws serve to mount the cabinet back to chassis frame.) Chassis and cabinet back can now be withdrawn from cabinet.
 2. Connect an output meter across the speaker voice coil or from the plate of the 50C5 tube to chassis through a 0.1 Mfd. condenser.
 3. Connect ground lead of signal generator to a B-terminal.
- CAUTION: If your signal generator is designed with an AC-DC power supply, connect ground lead to B-terminal through a 0.25 Mfd. condenser.
4. Set volume control at maximum and use a weak signal from the signal generator.
 5. Operate the receiver from a 117 volt AC or DC line.

DUMMY ANT. IN SERIES WITH SIGNAL GENERATOR	CONNECT HIGH SIDE OF SIGNAL GENERATOR TO	SIGNAL GENERATOR FREQUENCY	RECEIVER DIAL SETTING	TRIMMER NUMBER	TRIMMER DESCRIPTION	TYPE OF ADJUSTMENT
200 MMFD. Mica Condenser	Lug on Trimmer #4 at side of gang (See chart below for location of trimmer.)	455 KC 400 cycle AM Modulated	Any point where it does not affect the signal.	1-2	I.F.	Adjust for maximum output. Then repeat adjustment.
200 MMFD. Mica Condenser	External antenna lead	1650 KC 400 cycle AM Modulated	Turn Gang Condenser fully open	3	Broadcast Oscillator	Adjust for maximum output.
200 MMFD. Mica Condenser	External antenna lead	1500 KC 400 cycle AM Modulated	Tune to 1500 KC Generator Signal	4	Broadcast Antenna	Adjust for maximum output.

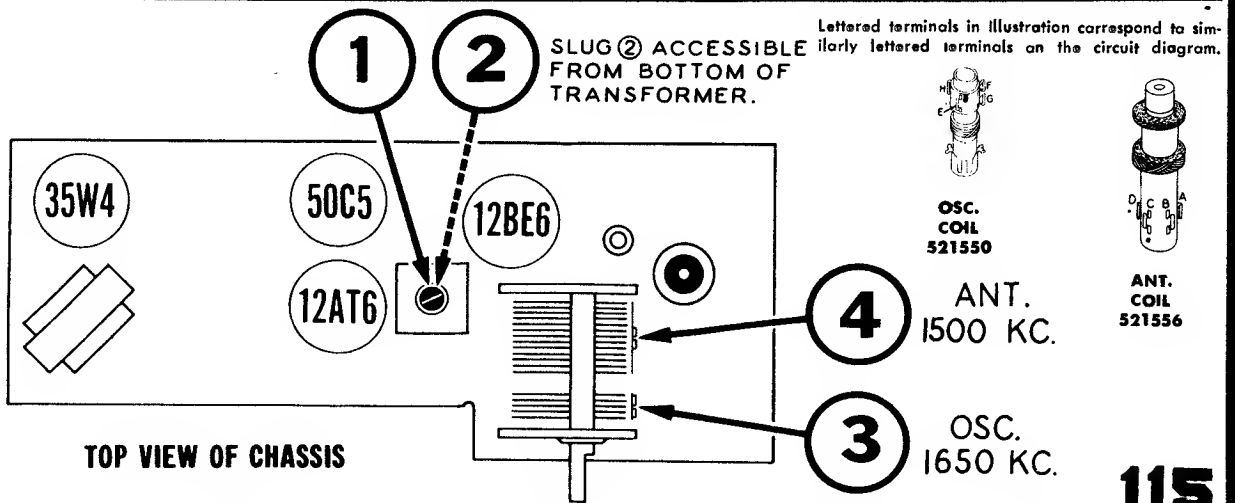

MANUAL OF 1954 MOST-OFTEN-NEEDED RADIO DIAGRAMS

STEWART-WARNER MODELS 9187-B, 9187-E, & 9187-J.

A number of other Stewart-Warner models use practically the identical circuit. Models 9186-A, -B, do not have an appliance outlet, but are exactly the same as 9187 models in all other respects. Models 9181-A, -C, -D, -E, -F, and 9182-C, -H, -J, are not clock-models and have different chassis layouts, but are almost identical to 9186 models in other details.

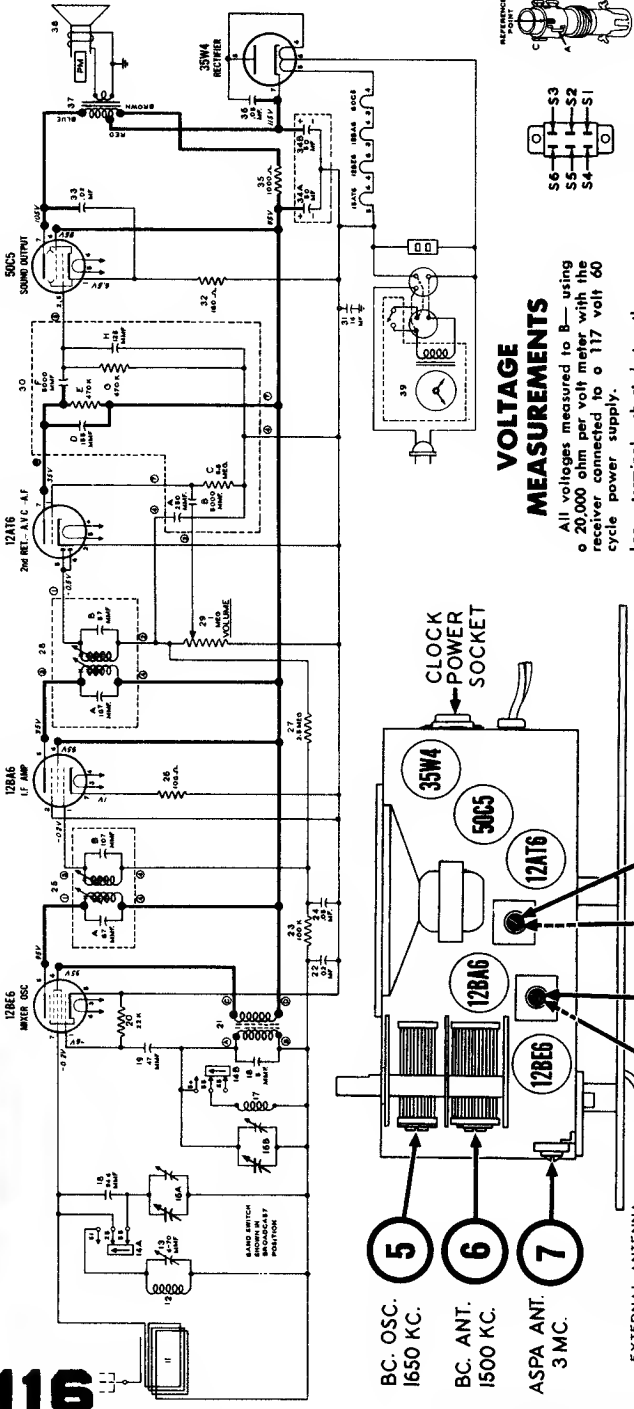

VOLTAGE MEASUREMENTS

All voltages measured to B—using a 20,000 ohm per volt meter with the receiver connected to a 117 volt 60 cycle power supply.

Loop terminals shorted together.

No voltage reading of a tube element indicates zero voltage or voltage which cannot be accurately measured with a 20,000 ohm per volt meter.

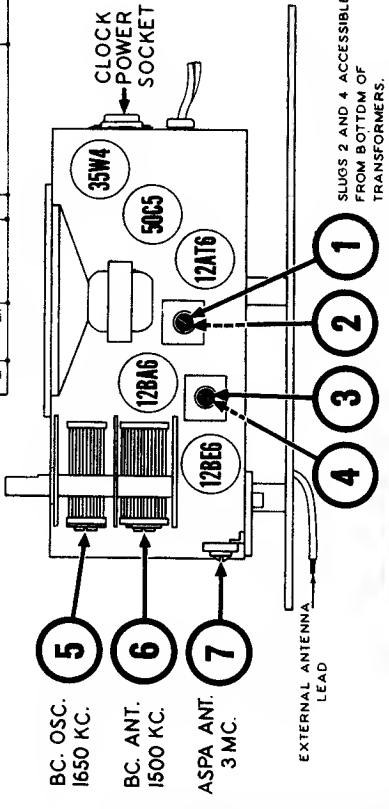

- 5 BC. OSC. 1650 KC.
- 6 BC. ANT. 1500 KC.
- 7 ASPA ANT. 3 MC.

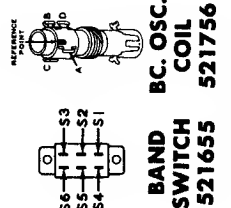

Lethered terminals in illustration correspond to similarly lettered terminals on the circuit diagram.

DUMMY ANT. IN SERIES WITH SIGNAL GENERATOR	CONNECT HIGH SIDE OF GENERATOR TO	SIGNAL GENERATOR FREQUENCY	BAND SWITCH POSITION	RECEIVER DIAL SETTING	TRIMMER NUMBER	TRIMMER DESCRIPTION	TYPE OF ADJUSTMENT
200 MMFD. Mica Condenser	Lug on Trimmer #6 of side of gang. (See chart above for location of trimmer.)	455 KC	Broadcast	Any point where it does not effect the signal	1-2 3-4	2nd I.F. 1st I.F.	Adjust for maximum output. Then repeat adjustment.
200 MMFD. Mica Condenser	External Antenna lead on Cabinet Back	1650 KC	Broadcast	Turn Gang Condenser fully open	5	Broadcast Oscillator	Adjust for maximum output.
200 MMFD. Mica Condenser	External Antenna lead on Cabinet Back	1500 KC	Broadcast	Tune to 1500 KC generator signal	6	Broadcast Antenna	Adjust for maximum output.
400 OHM Resistor	External Antenna lead on Cabinet Back	3 MC	ASPA BAND	Tune to 3 MC generator signal	7	ASPA Antenna	Adjust for maximum output. Try to increase output by detuning trimmer and returning receiver dial until maximum output is obtained.

MANUAL OF 1954 MOST-OFTEN-NEEDED RADIO DIAGRAMS

Stromberg-Carlson

HFT SERVICE NOTES — STROMBERG-CARLSON HI FI ET
EXTENDED RANGE PORTABLE PHONOGRAPH

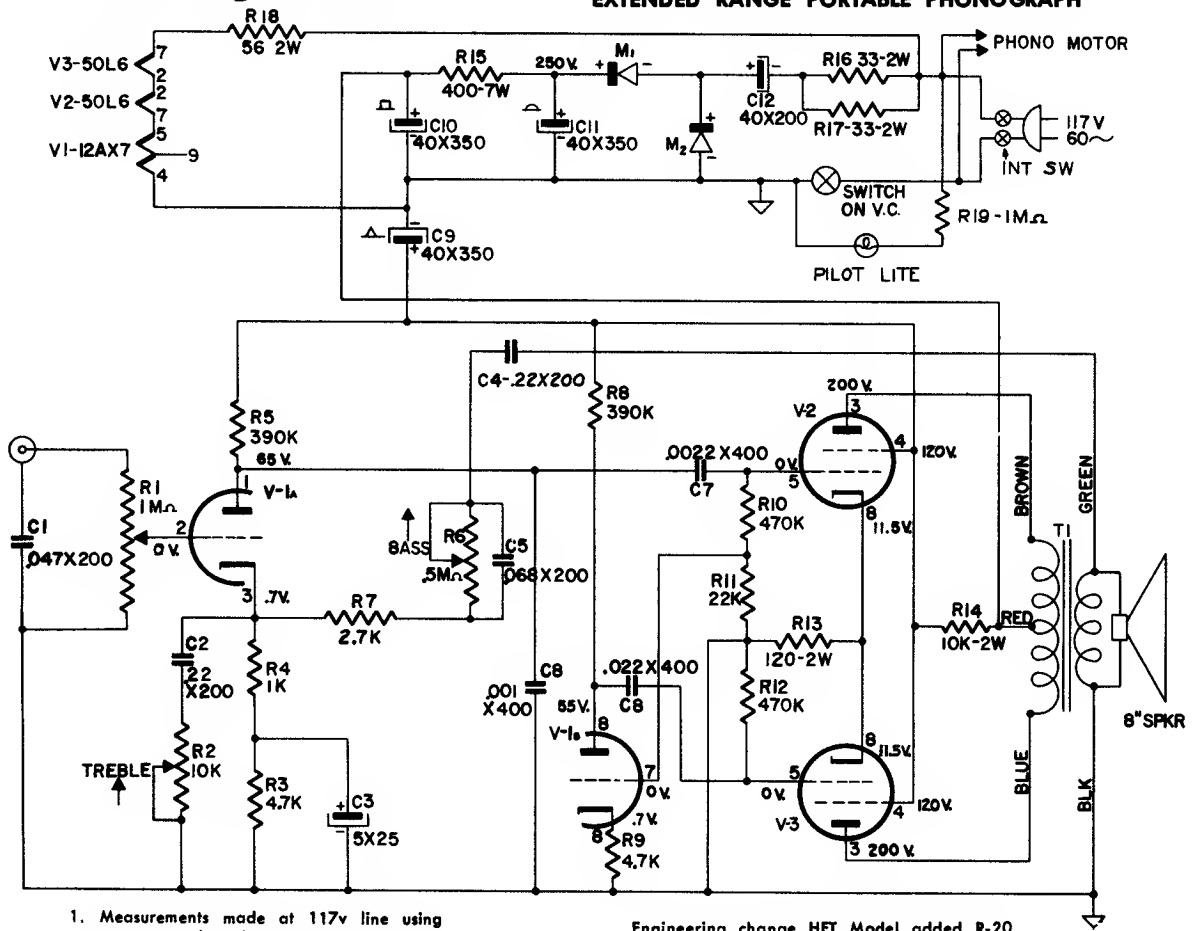

1. Measurements made at 117v line using vacuum tube voltmeter.
2. All voltages are DC and are positive with respect to chassis ground.

Engineering change HFT Model added R-20 390K 10% 1/2 w Stromberg-Carlson Part No. 28186 from center point of Volume Control to gnd. end of C-1 .047 Capacitor.

STROMBERG-CARLSON

Extended Range Portable Phonograph

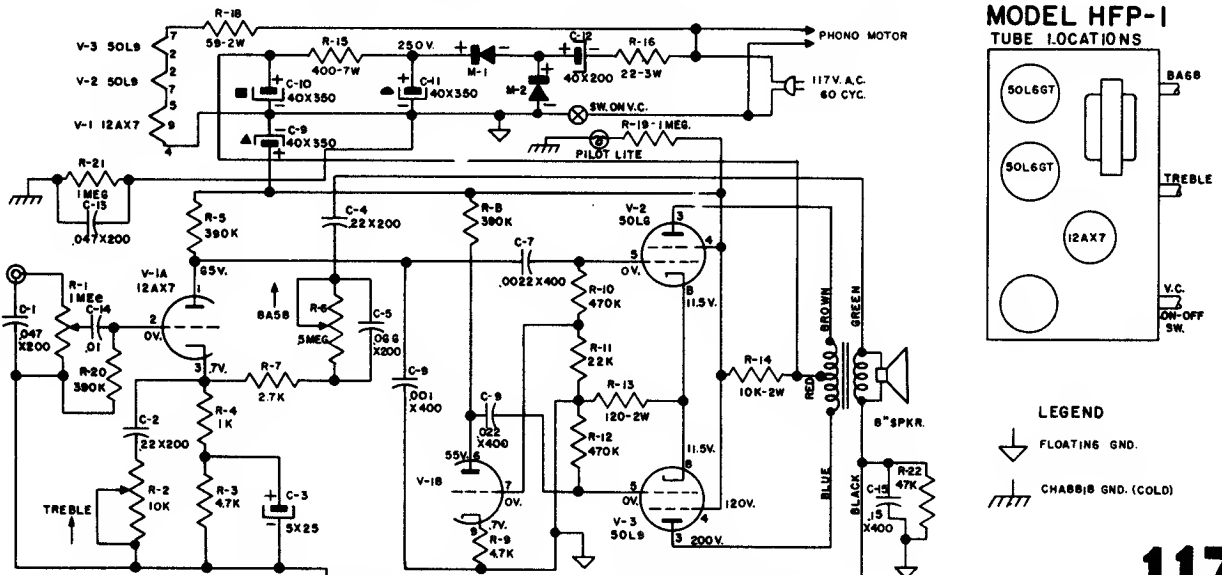

MODEL HFP-1 TUBE LOCATIONS

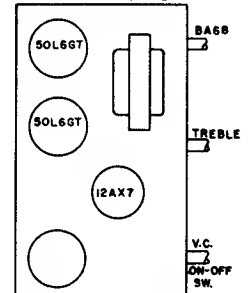

LEGEND

- FLOATING GND.
- CHASSIS GND. (COLD)

MANUAL OF 1954 MOST-OFTEN-NEEDED RADIO DIAGRAMS

Stromberg-Carlson Service Notes

Battery Portable Radio Receiver BP-1

TUBE COMPLEMENT

- 1 — 1R5 Converter
- 1 — 1U4 I.F. Amp.
- 1 — 1U5 Detector — Audio Amp.
- 1 — 3V4 Audio Output

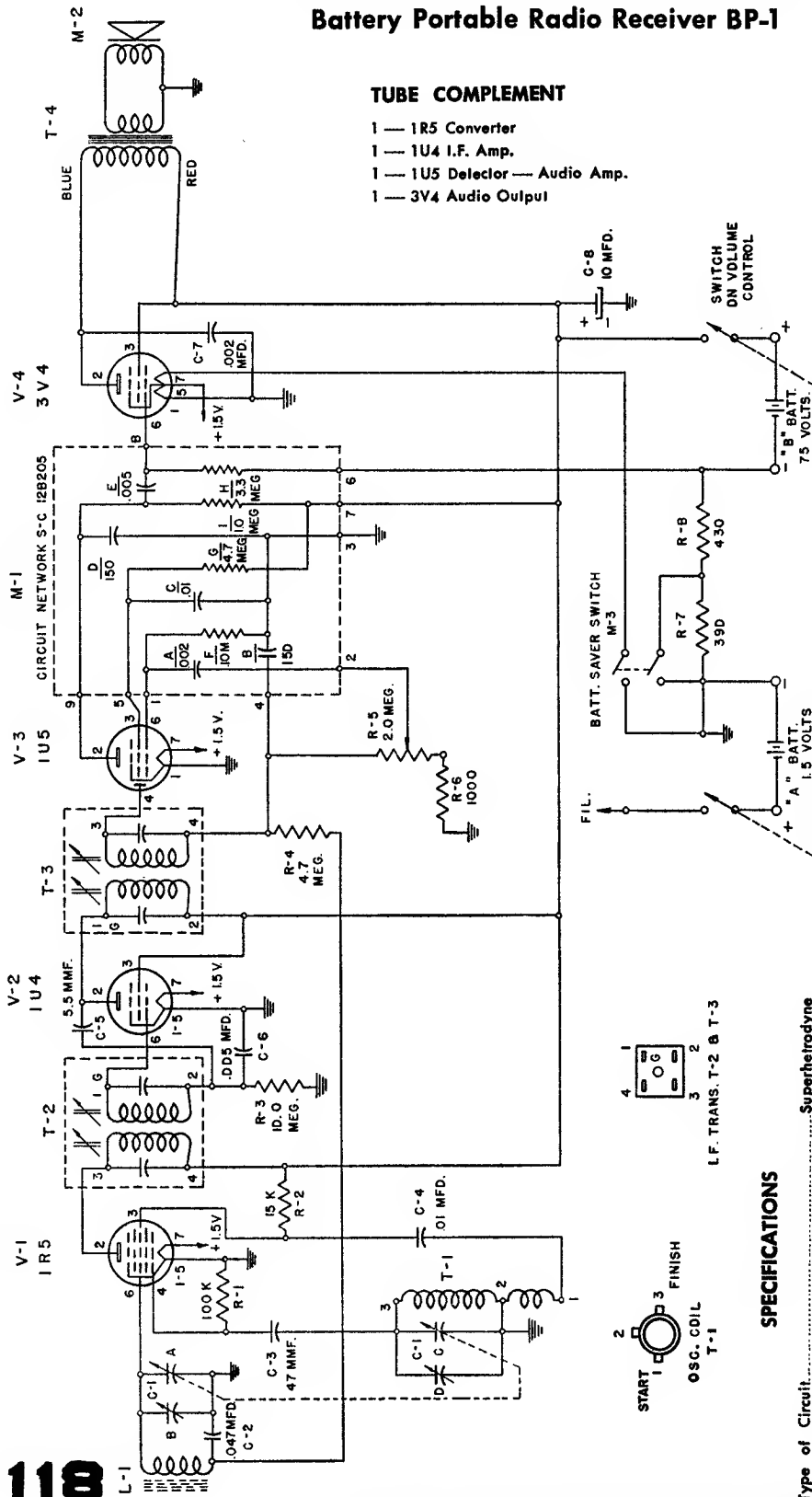

VOLTAGE CHART

Voltages obtained using VTVM. Battery sever switch in full battery position. All voltages are D.C. and are positive with respect to chassis ground except where otherwise noted.

TUBE	FUNCTION	PIN NUMBER						
V-1 1R5	Converter	1	2	3	4	5	6	7
V-2 1U4	I.F. Amp.	0	71	42	-7.1	0	-35	1.45
V-3 1U5	(Detector 1st audio)	0	70	70	NC	0	-125	1.45
V-4 3V4	Output	0	20.5	19	-6	NC	-25	1.45
		0	67.5	70	NC	1.45	-37	0

SPECIFICATIONS

- Type of Circuit.....Superheterodyne
- Tuning Range.....AM Broadcast 540 to 1620 KC
- Intermediate Frequency.....455 KC
- Power Supply — Stromberg-Carlson Battery Kit No. 10, Part No. 141037. Consists of 2 "A" batteries (1.5 volts each) and 1 "B" battery (75 volts) of the following manufacturer types:

MANUFACTURER	"A" BATTERY (1.5 VOLTS)	"B" 75 VOLTS
Eveready	964	437
N.E.D.A.	20	212
Burgess	21 R	XX50
R.C.A.	VS 236	VS 217
General	77	144
Philco	P-77	P-144
Ray-O-Vac	8 R	4375

MANUAL OF 1954 MOST-OFTEN-NEEDED RADIO DIAGRAMS

SYLVANIA CHASSIS 1-601-4 and 1-601-5

MODEL 568 and 5184

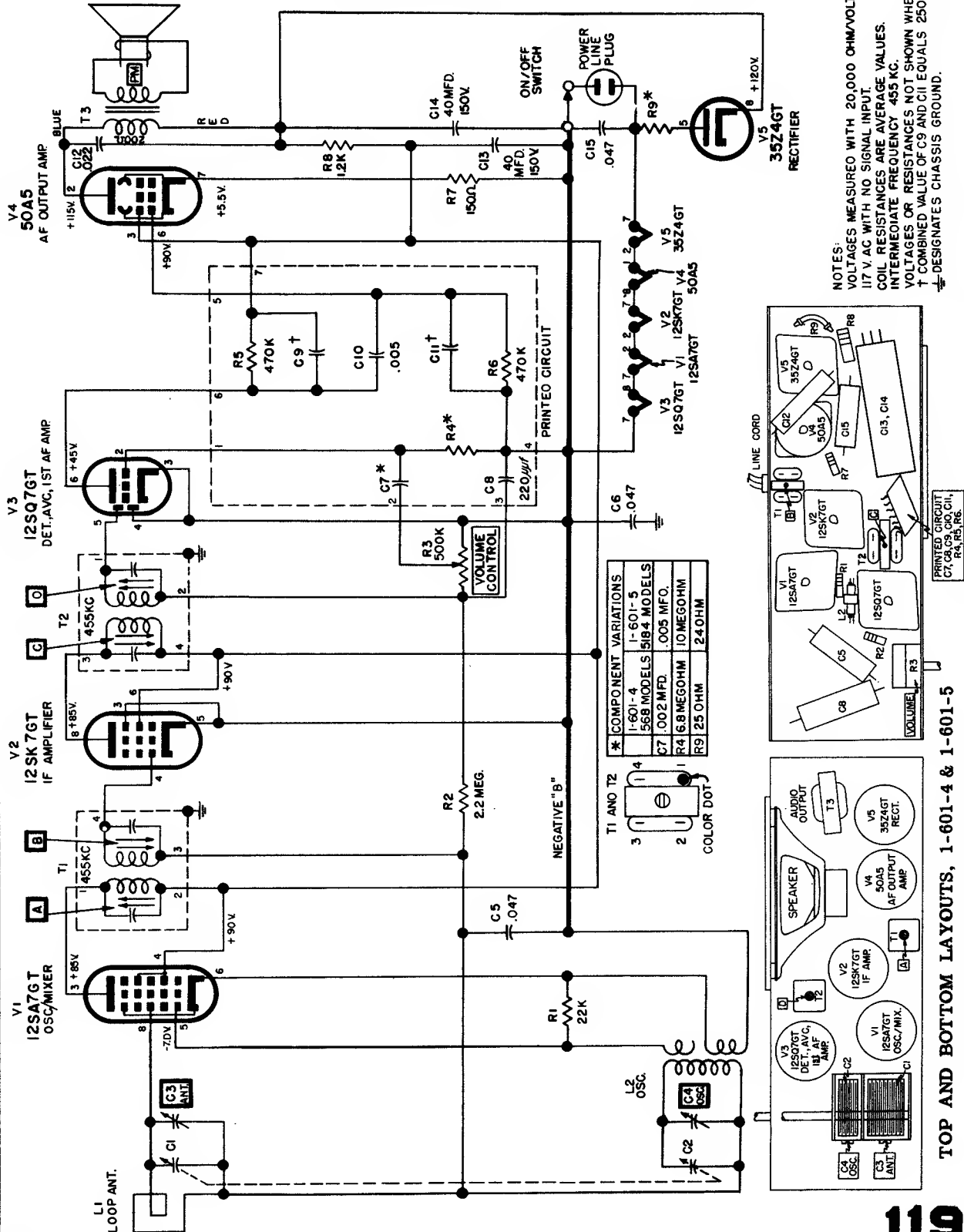

TOP AND BOTTOM LAYOUTS, 1-601-4 & 1-601-5

MANUAL OF 1954 MOST-OFTEN-NEEDED RADIO DIAGRAMS

SYLVANIA ELECTRIC PRODUCTS INC.

Chassis 1-603-1 and 1-603-2 (Continued on page 121)

FM IF ALIGNMENT

STEP	SIGNAL GENERATOR Connection	Freq.	SWEEP GENERATOR Connection	Freq.	OSCILLOSCOPE CONNECTION	ADJUST	OUTPUT READING	COMMENTS
1.	Loosely couple marker to pin 1 of 1st IF Amp. - 6BA6	10.6 MC 10.7 MC 10.8 MC	To pin 1 of 1st IF Amp. - 6BA6	10.7 MC	Thru detector circuit of Figure A to pin 5 of 2nd IF Amp. - 6AU6	T3 - F T3 - E	Response curve of Figure B	Connect 500 ohm resistor from pin 5 to pin 6 of 2nd IF Amp. - 6AU6. Obtain maximum vertical amplitude for response curve. Set sweep generator for approximately 500 KC to 1 MC sweep.
2.	Loosely couple marker to pin 7 of Osc. - Mixer - 6BE6.	10.6 MC 10.7 MC 10.8 MC	To pin 7 of Osc. Mixer - 6BE6.	10.7 MC	Same as 1.	T1 - B T1 - A	Response curve of Figure B	Same as 1; reduce sweep generator output to avoid AVC distortion of response curve.
3.	Loosely couple marker to pin 1 of 2nd IF Amp. - 6AU6.	10.6 MC 10.7 MC 10.8 MC	To pin 1 of 2nd IF Amp. - 6AU6	10.7 MC	Across de-emphasis capacitor, C37 .0033 Mfd.	T5 - K T5 - J	Response curve of Figure C	REMOVE 500 OHM RESISTOR ADDED FOR STEP 1. Center 10.7 MC marker. Obtain maximum linear output for response curve.

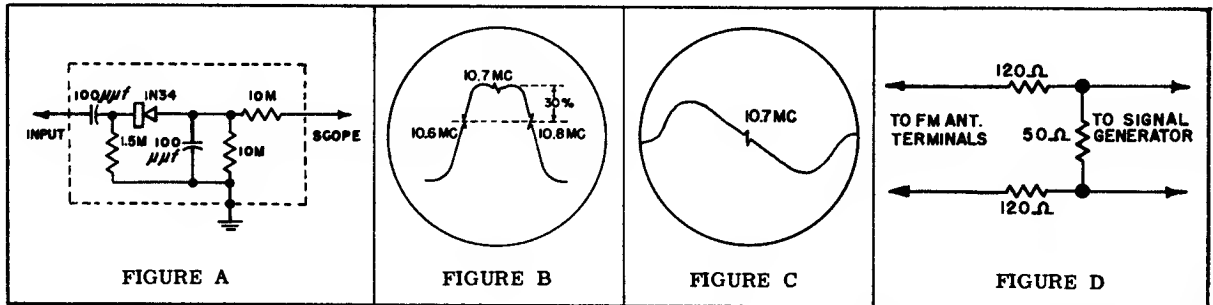

FM RF ALIGNMENT

STEP	SIGNAL GENERATOR Connection	Freq.	TUNING CAPACITOR POSITION	OUTPUT METER CONNECTION	ADJUST	OUTPUT READING	COMMENTS
1.	Thru resistor network of Figure D to FM antenna terminal board.	108.5 MC	Fully open	Across speaker voice coil.	C9	Maximum	Set Volume control to full CW position and set Tone control to full CCW position. Use a 400 cycle modulated signal. Keep generator output at lowest usable value. Leave AM loop antenna leads connected during FM RF alignment.
2.	Same as 1.	108 MC	108 MC	Same as 1.	C8	Maximum	Same as 1 using printed calibration dial on chassis assembly to properly position tuning capacitor.
3.	Same as 1.	87.5 MC	Fully closed	Same as 1.	L5 coil	Maximum	Same as 1 "spiking" (squeezing or spreading turns of coil) L5 for maximum output reading. Use a non-metallic pick for this adjustment.
4.	Same as 1	88 MC	88 MC	Same as 1.	L4 coil	Maximum	Same as 2 "spiking" (squeezing or spreading turns of coil) L4 for maximum output reading. Use a non-metallic pick for this adjustment.

AM ALIGNMENT

STEP	SIGNAL GENERATOR Connection	Freq.	TUNING CAPACITOR POSITION	OUTPUT METER CONNECTION	ADJUST	OUTPUT READING	COMMENTS
1.	Thru .1 Mfd. capacitor to pin 7 of Osc. - Mixer - 6BE6.	455 KC	Fully open	Across speaker voice coil.	T4 - H T4 - G T2 - D T2 - C	Maximum	Set Volume control to full CW position and set Tone control to full CCW position. Use a 400 cycle modulated signal. Keep generator output at lowest usable value.
2.	Radiated to receiver thru a wire loop of several turns. or: Thru a 50 Mmfd. capacitor to AM antenna board.	1650 KC	1650 KC	Same as 1.	C12	Maximum	Same as 1 using printed calibration dial on chassis assembly to properly position tuning capacitor.
3.	Same as 2.	1400 KC	1400 KC	Same as 1.	C3	Maximum	Same as 2.

MANUAL OF 1954 MOST-OFTEN-NEEDED RADIO DIAGRAMS

SYLVANIA

CHASSIS 1-603-1 and 1-603-2

(Continued from page 120)

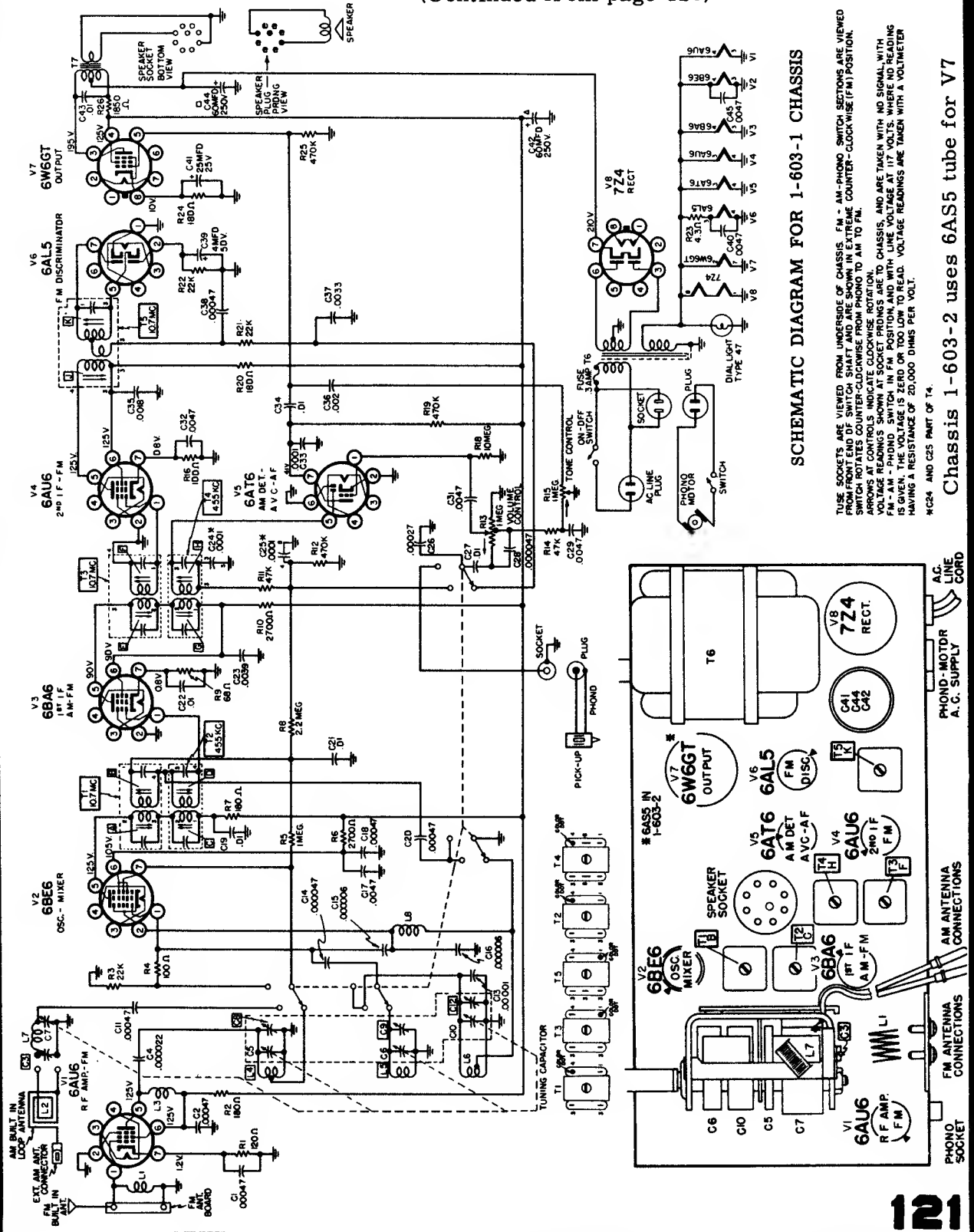

SCHEMATIC DIAGRAM FOR 1-603-1 CHASSIS

THESE SOCKETS ARE VIEWED FROM UNDERSIDE OF CHASSIS. FM - AM-PHONO SWITCH SECTIONS ARE VIEWED SWITCH ROTATING CLOCKWISE FROM PHONO TO AM POSITION. AM - FM SWITCH SECTIONS ARE VIEWED SWITCH ROTATING COUNTER-CLOCKWISE FROM PHONO TO AM TO FM. ARROWS AT CONTROLS INDICATE CLOCKWISE ROTATION. VOLTAGE READINGS SHOWN AT SOCKET PRINGS ARE TO CHASSIS, AND ARE TAKEN WITH NO SIGNAL, WITH FM - AM - PHONO SWITCH IN FM POSITION, AND WITH LINE VOLTAGE AT 117 VOLTS. WHERE NO READING IS GIVEN, THE VOLTAGE IS ZERO OR TOO LOW TO READ. VOLTAGE READINGS ARE TAKEN WITH A VOLTMETER HAVING A RESISTANCE OF 20,000 OHMS PER VOLT.

*C624 AND C625 PART OF T4.

Chassis 1-603-2 uses 6AS5 tube for V7

MANUAL OF 1954 MOST-OFTEN-NEEDED RADIO DIAGRAMS

SYLVANIA RADIO CHASSIS 1-606-1

MODEL 454 PORTABLE RADIOS

STEP	SIGNAL GENERATOR Freq.	GENERATOR Connection	TUNING CAPACITOR SETTING	ADJUST	COMMENTS
1.	455KC Modulated	Hot side through .01 Mfd. to pin 6 of 1R5 Osc. - Mixer, ground to chassis.	Tuning Capacitor plates fully open.	T2D T2C T1B T1A	Adjust T1 and T2 for maximum output indication. Reduce output of signal generator, as alignment progresses, to prevent overload of receiver.
2.	1700KC Modulated		Tuning Capacitor plates fully open.	C5 Osc. Trimmer for maximum.	These are preliminary adjustments only, and locate approximate settings of C5 and L2. Steps 4, 5 and 6 must now be observed.
3.	530KC Modulated			L2 Osc. Slug for maximum.	
4.	1450KC Modulated	Radiated to receiver through loop of several turns.	Position where signal generator output is heard.	C5 Osc. Trimmer for maximum.	Rock tuning capacitor while adjusting C5 and L2 at respective frequencies, until no further increase of output is obtained with a given level of signal generator output.
5.	600KC Modulated.			L2 Osc. Slug for maximum.	
6.	Steps 4 and 5 must be repeated until maximum output is obtained.				

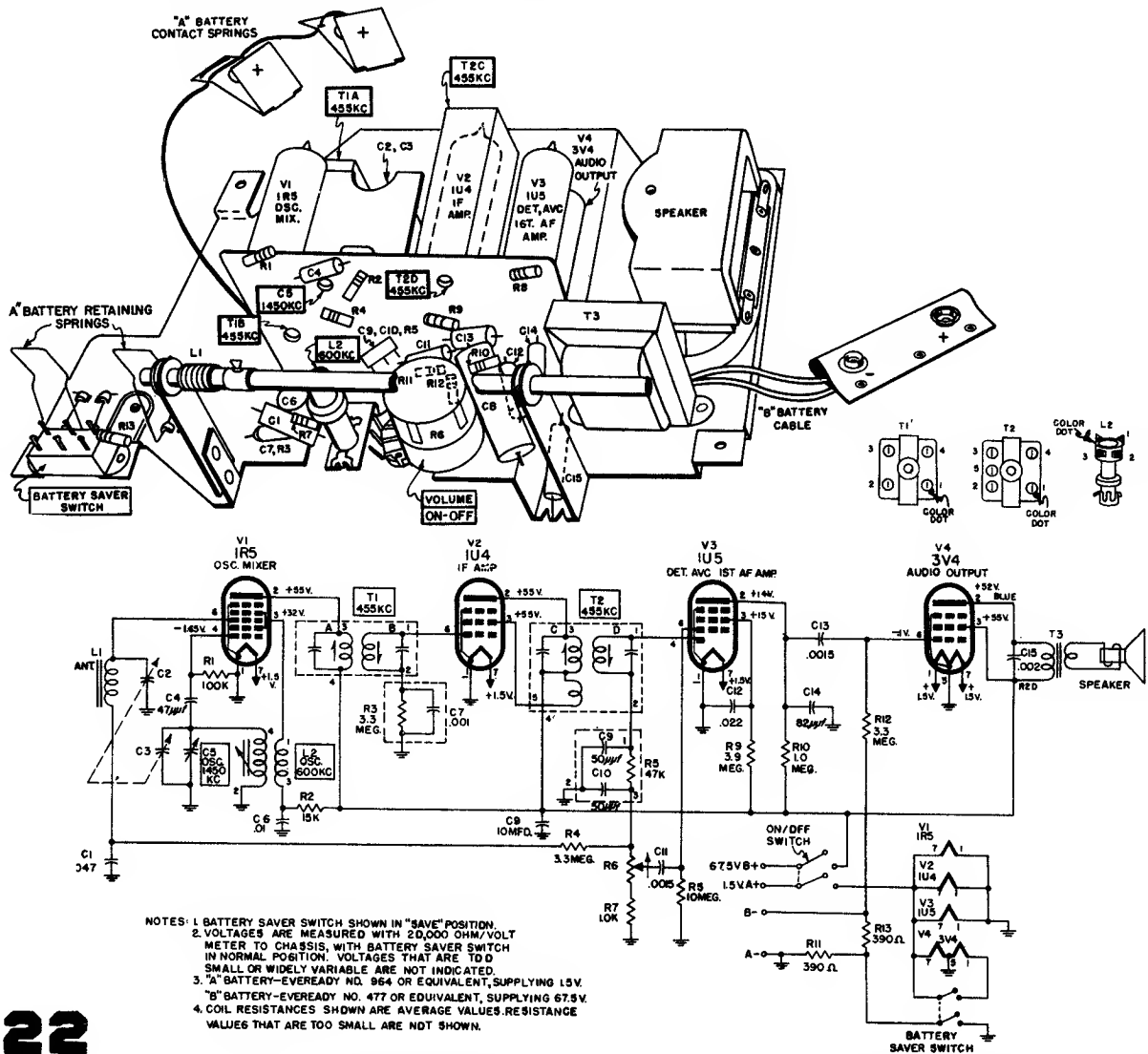

MANUAL OF 1954 MOST-OFTEN-NEEDED RADIO DIAGRAMS

TRAVLER

Model 5091

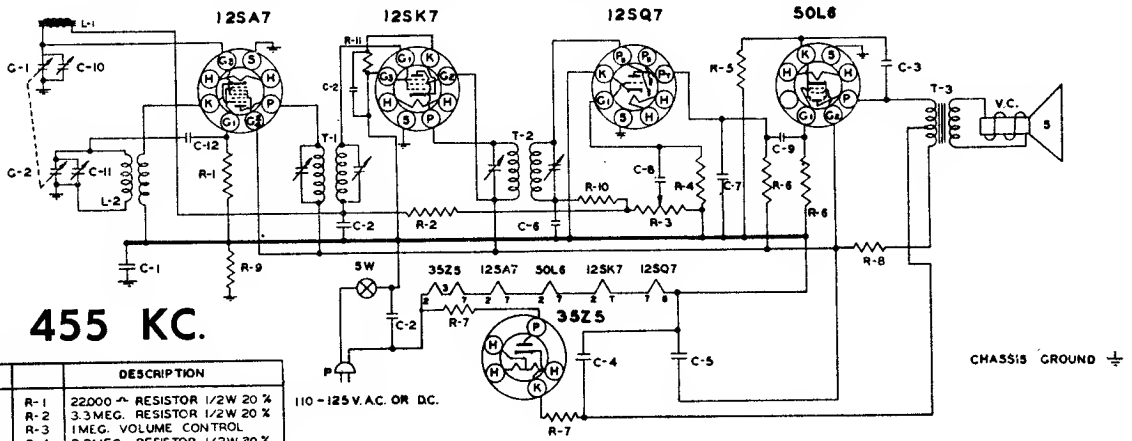

I.F. 455 KC.

PART NO.	DESCRIPTION
1R-9	R-1 22000 Ω RESISTOR 1/2W 20 %
1R-23	R-2 3.3 MEG. RESISTOR 1/2W 20 %
VC-48	R-3 1 MEG. VOLUME CONTROL
1R-13	R-4 2.2 MEG. RESISTOR 1/2W 20 %
1R-14	R-5 150 Ω RESISTOR 1/2W 20 %
1R-11	R-6 470 M Ω RESISTOR 1/2W 20 %
1R-17	R-7 33 Ω RESISTOR 1/2W 20 %
1R-42	R-8 1000 Ω RESISTOR 1 W 10 %
1R-20	R-9 220M Ω RESISTOR 1/2W 20 %
1R-10	R-10 47000 Ω RESISTOR 1/2W 20 %
1R-6	R-11 470 Ω RESISTOR 1/2 W 10 %
PC-8	C-1 1MFD. CONDENSER 400V.
PC-5	C-2 .05MFD. CONDENSER 400V.
PC-7	C-3 .01MFD. CONDENSER 400V.
EC-24	C-4 50MFD. 150V. ELECTROLYTIC
	C-5 50MFD.
	C-6 220MMFD.
MC-6	C-7 220MMFD.
	C-8 .002MFD.
	C-9 .005MFD.
	C-10 ANT. TRIMMER.
MC-4	C-11 OSC. TRIMMER
GC-5E	C-12 50MMFD. MICA CONDENSER
	G-1 GANG CONDENSEP
LL-34	L-1 FERRAMIC ROD ANTENNA
LO-13	L-2 OSC. COIL
LI-6	T-1 INPUT I.F. TRANSFORMER
LI-7	T-2 OUTPUT I.F. TRANSFORMER.
SPK-32	T-3 SPEAKER OUTPUT TRANSFORMER
	V.C. VOICE COIL.
	S P.M. SPEAKER
CO-1	SW A.C. SWITCH ON VOLUME CONTROL
	P LINE CORD

110 - 125 V. AC. OR DC.

CHASSIS GROUND

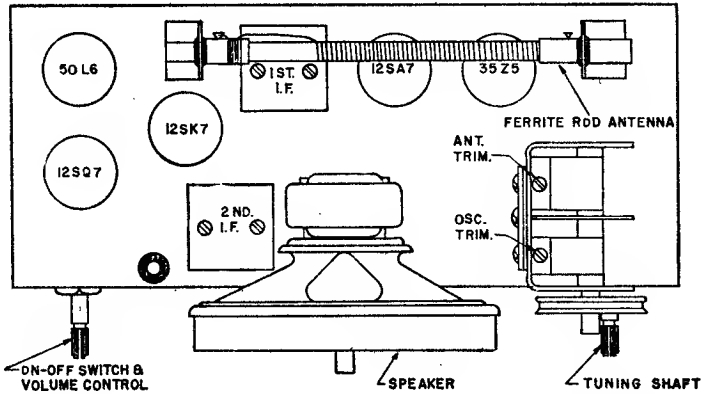

TRAV-LER Models 5180A, 5180B, 5180M

TUBE & TRIMMER LOCATION MODEL-5180A

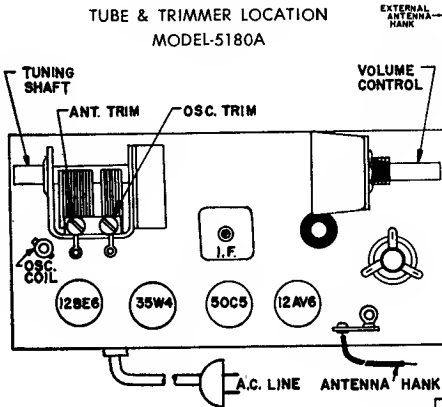

I.F. 455 KC.

Models 5180A, -B, -M

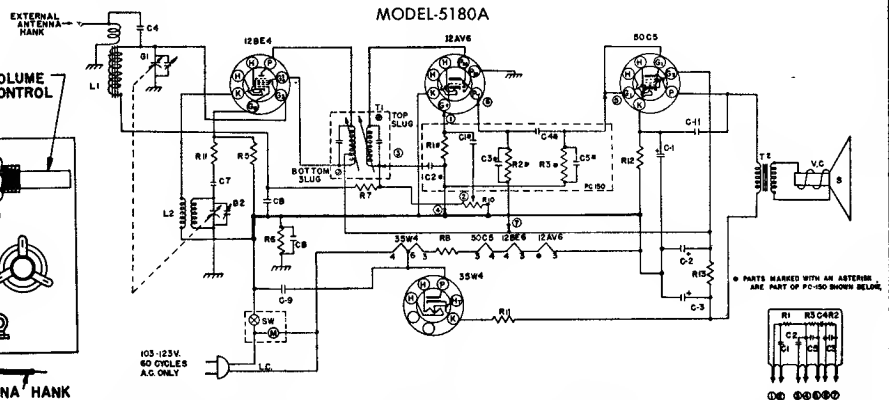

PART NO.	SYMBOL	DESCRIPTION	PART NO.	SYMBOL	DESCRIPTION
CG-21	G-1	10MFD CERAMIC CONDENSER	1R-14	R-12	50 OHM 1/2 W 20% CARBON RESISTOR
CG-12	OT	47MFD CERAMIC CONDENSER	1R-25	R-13	2200 OHM 1W 10% CARBON RESISTOR
PG-2	CB	10MFD PAPER CONDENSER		C-1	10MFD - 25W VDC ELECTROLYTIC CONDENSER
PG-5	CB	10MFD PAPER CONDENSER 400V.	EC-28A	C-2	20MFD - 50W VDC. CONDENSER
OK-2	M	ELECTRIC CLOCK ASSEMBLY		C-3	40MFD - 50W VDC. AC LINE CORD
CG-3	CI	205 WFD. CONDENSER		L-1	ANT. SECTION-WITH TRIMMER. GANG
MC-19	PC-80	COUPLATE		G-1	OSC SECTION-WITH TRIMMER. CONDENSER
			GC-12	G-2	OSC SECTION-WITH TRIMMER. CONDENSER
1R-8	R-5	22R OHM 1/2W 20% CARBON RESISTOR	LA-4	L-1	ANTENNA COIL
1R-20	R-6	220K OHM 1/2W 20% CARBON RESISTOR	LO-20	L-2	OSCILLATOR COIL
1R-25	R-7	5.3MFD 1/2W 20% CARBON RESISTOR	LI-12	T-1	455 KC TAPPED PRIMARY-I.F. COIL
1R-41	R-8	470K OHM 1W 10% CARBON RESISTOR		SW	[SWITCH(PART OF CLOCK ASSEMBLY)]
VC-49	R-10	1 MEG OHM VOLUME CONTROL		T-2	OUTPUT TRANSFORMER 4" P.M.
1R-17	R-11	330M OHM 1/2W 20% CARBON RESISTOR	SPK-OR	V.C	VOICE COIL WINDING
				S	SPEAKER

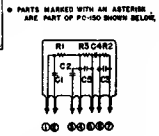

COMPONENTS & VALUES OF PC-80
 C1-2000 MFD
 C2-500 MFD
 C3-100MFD
 C4-500MFD
 R1-5 MEG OHM
 R2-47 MEG OHM
 R3-47 MEG OHM

MANUAL OF 1954 MOST-OFTEN-NEEDED RADIO DIAGRAMS

TRAVLER

Models 5182-B, 5182-M

Align IF sections at 455 KC, adjust oscillator trimmer with signal generator producing 1630 KC, antenna trimmer with a 1400 KC signal.

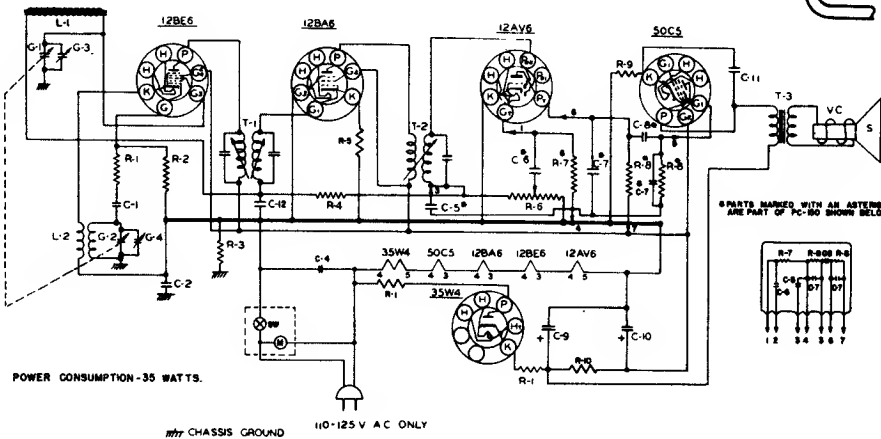
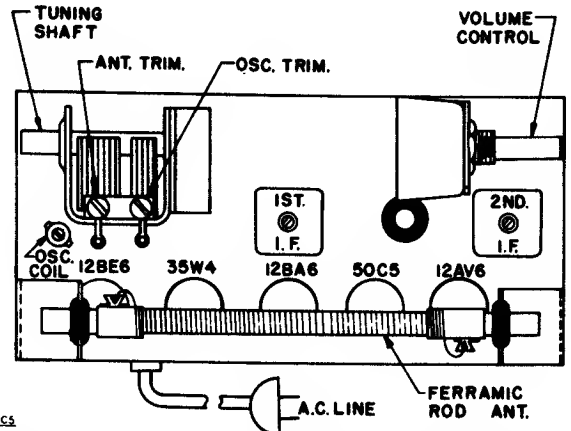

PART NO.	DESCRIPTION
IR-17	R-1 33Ω RESISTOR 1/2W 20%
IR-9	R-2 220Ω RESISTOR 1/2W 20%
IR-20	R-3 33MΩ RESISTOR 1/2W 20%
IR-23	R-4 100Ω RESISTOR 1/2W 10%
IR-22	R-5 1MΩ VOLUME CONTROL
VC-99	R-7 1.8MΩ 4700PμF
IR-14	R-8 150Ω RESISTOR 1/2W 20%
IR-25	R-9 220Ω RESISTOR 1W 10%
LI-10	T-1 INPUT I.F. TRANSFORMER
LI-11	T-2 OUTPUT I.F. TRANSFORMER
GC-12	C-1 47 MFD 50V CERAMIC CONDENSER
PC-8	C-2 1 MFD. CONDENSER 400 V.
PC-5	C-4 50MFD. CONDENSER 400 V.
GC-9	C-5 100MFD.
GC-8	C-6 500MFD.
GC-7	C-7 500MFD.
GC-6	C-8 100MFD.
GC-5	C-9 40MFD.
GC-4	C-10 20MFD. 100V.D.C. ELECTROLYTIC
GC-3	C-11 100MFD. CONDENSER
GC-2	C-12 50MFD. CERAMIC CONDENSER
GC-1	C-13 TUNING CONDENSER
GC-10	C-14 47M. SPEAKER
SPK-22B	OR VC VOICE COIL
SPK-24	OR T-3 OUTPUT TRANSFORMER
LL-38	L-1 FERRAMIC ROD ANTENNA
LO-20	L-2 OSC. COIL
GH-1	M ELECTRIC PLUG
SW	SW SWITCH PART OF CLOCK ASSEMBLY

Model 5305

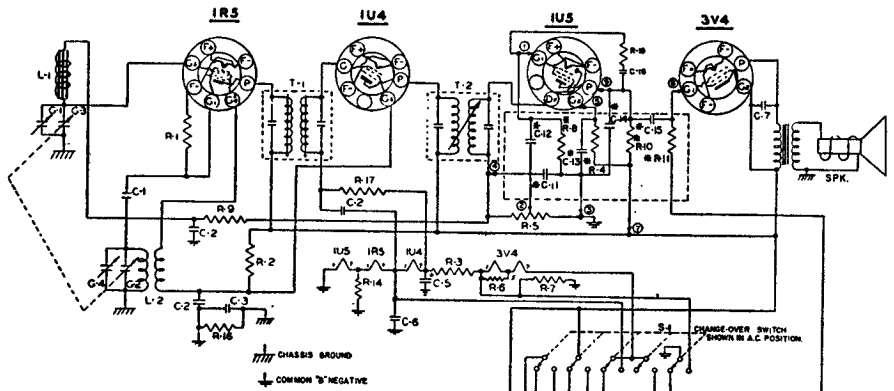
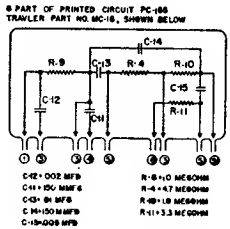

I.F. 455 KC.

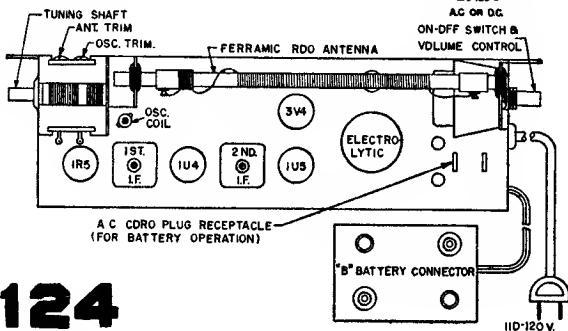

PART NO.	SYMBOL	DESCRIPTION	PART NO.	SYMBOL	DESCRIPTION
IR-25	R-1	100Ω 1/2W 10% RESISTOR	GC-20	C-7	500MFD 200V CERAMIC CONDENSER
IR-25	R-2	100Ω 1/2W 10% RESISTOR	GC-19	C-8	100K ELECTROLYTIC
IR-17	R-3	33Ω 1/2W 20% RESISTOR	GC-18	C-9	40MFD CONDENSER
VC-47	R-4	1MΩ VOLUME CONTROL	LO-18	C-10	20MFD
IR-22	R-5	100Ω 1/2W 10% RESISTOR	LO-19	C-11	OSCILLATOR COIL
IR-39	R-7	620Ω 1/2W 5% RESISTOR	LL-30	L-1	FERRAMIC ROD ANTENNA
IR-3	R-8	150Ω 1/2W 20% RESISTOR	LI-10	T-1	INPUT I.F. TRANSFORMER
IR-23	R-9	220Ω 1W 10% RESISTOR	LI-11	T-2	OUTPUT I.F. TRANSFORMER
WR-7A	R-10	2200Ω 1/2W 5% WIREWOUND RESISTOR	GC-12	C-1	47MFD. TUNING CAPACITOR
IR-1	R-11	100Ω 1/2W 20% RESISTOR	GC-11	C-2	1MFD. ANTENNA TRIMMER
IR-41	R-12	100Ω 1/2W 10% RESISTOR	GC-10	C-3	50MFD. OSCILLATOR TRIMMER
IR-20	R-13	33MΩ 1/2W 20% RESISTOR	GC-9	C-4	100MFD. SWITCH (SHOWN IN A.C. POS.)
PC-5	C-1	100MFD 500V	GC-8	C-5	100MFD. SWITCH (SHOWN IN A.C. POS.)
GC-2	C-2	10MFD CERAMIC CONDENSER 500V	GC-7	C-6	75MFD BELLEVUE RECTIFIER
PC-6	C-3	1MFD PAPER CONDENSER 400V	SPK-22	SPK	47M. SPEAKER WITH OUTPUT TRANSFORMER
PC-4	C-4	50MFD 400V PAPER CONDENSER	IR-3	R-14	2MΩ 1/2W 20% RESISTOR
GC-5	C-5	10MFD 50V ELECTROLYTIC CONDENSER	PC-3	C-6	220MFD 200V 5% CERAMIC CONDENSER
PC-3	C-6	1MFD 200V PAPER CONDENSER			

MANUAL OF 1954 MOST-OFTEN-NEEDED RADIO DIAGRAMS

TRAVLER Model 5356

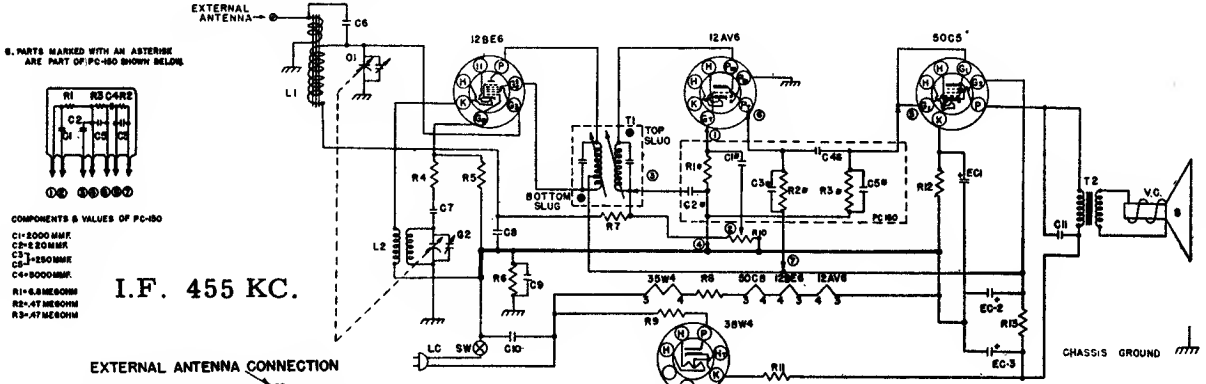

8. PARTS MARKED WITH AN ASTERISK ARE PART OF PC-150 SHOWN BELOW

COMPONENTS & VALUES OF PC-150

C1-5000MMF
C2-220MMF
C3-250MMF
C4-9000MMF
R1-4.8MEG OHM
R2-47MEG OHM
R3-47MEG OHM

I.F. 455 KC.

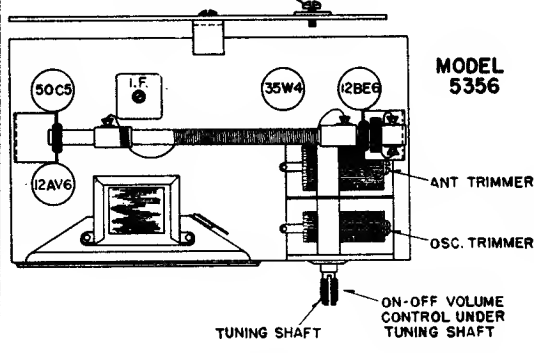

PART NO	SYMBOL	DESCRIPTION	PART NO	SYMBOL	DESCRIPTION
CC-21	C6	10MMF CERAMIC CONDENSER	IR-14	R-12	150 OHM 1/2W 20% CARBON RESISTOR
CC-12	07	47MMF CERAMIC CONDENSER	IR-25	R-13	2200 OHM 1W 10% CARBON RESISTOR
PC-5	C8	0.05MF PAPER CONDENSER 400 V.	EC-1	EC-1	10MF -25WVDC ELECTROLYTIC CONDENSER
PC-5	C9	0.05MF PAPER CONDENSER 400 V.	EC-2	EC-2	20MF -50WVDC ELECTROLYTIC CONDENSER
PC-5	C10	0.05MF PAPER CONDENSER 400 V.	EC-3	EC-3	40MF -50WVDC ELECTROLYTIC CONDENSER
PC-6	C11	0.05MF PAPER CONDENSER 600V	LC	LC	AC LINE CORD
MG-18	PC-50	COUPLATE	CO-1	CO-1	ANT SECTION WITH TRIMMER
IR-17	R-4	33 OHM 1/2W 20% CARBON RESISTOR	OC-7X	G1	OSC SECTION WITH TRIMMER
IR-9	R-5	22K OHM 1/2W 20% CARBON RESISTOR	LL-32	L1	FERRIMAG ROD ANTENNA COIL
IR-20	R-6	520K OHM 1/2W 20% CARBON RESISTOR	LD-14	L2	OSCILLATOR COIL
IR-23	R-7	53MEG OHM 1/2W 20% CARBON RESISTOR	L1-12	T1	455 KC TAPPED PRIMARY-IF COIL
IR-41	R-8	47 OHM 1W 10% CARBON RESISTOR	SW	SW	5 PST SWITCH (PART OF VOLUME CONTROL)
IR-17	R-9	33 OHM 1/2W 20% CARBON RESISTOR	T-2	T-2	OUTPUT TRANSFORMER
IR-17	R-10	1MEG OHM VOLUME CONTROL	V.C	V.C	VOICE COIL WINDING
IR-17	R-11	33 OHM 1/2W 20% CARBON RESISTOR	SPK-22A	S	SPEAKER

TRAV-LER Phonograph Models 9051, 9052, 9060, and 9061

TRAVLER

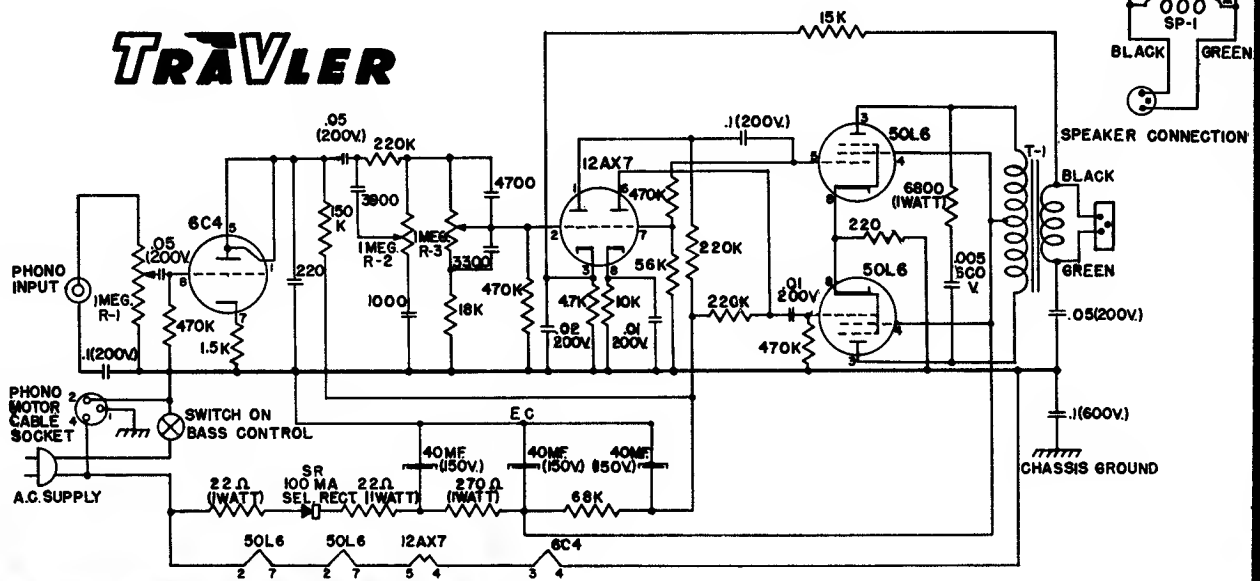

SYMBOL	PART NO	DESCRIPTION
R-1	VC-46	1 MEG OHM CONTROL AUDIO TAPER.
R-2	VC-45	1 MEG OHM CONTROL LINEAR TAPER.
R-3	VC-44	1 MEG OHM CONTROL LINEAR TAPER WITH S.P.S.T. SWITCH.
EC	EC-29	40-40-40 @ 150 W.V. ELECTROLYTIC.
SR	SR-4	100 MA SELENIUM RECTIFIER.
T-1	AT-12	PUSH PULL OUTPUT TRANSFORMER.
SP-1	SPK-27	6" P.M. SPEAKER, 3.2 OHM VOICE COIL.
SP-2	SPK-28	3" P.M. SPEAKER, 3.2 OHM VOICE COIL.

- NOTES:**
1. INDICATES START OF VOICE COIL MARKED BY RED DOT, REVERSE PHASING OF SPEAKERS WILL CAUSE LOSS OF BASS.
 2. REVERSE PHASING OF FEEDBACK WILL CAUSE AMPLIFIER TO OSCILLATE.
 3. POLARIZE A.C. PLUG FOR MINIMUM HUM.
 4. RESISTORS TO BE 1/2 WATT UNLESS OTHERWISE SHOWN.
 5. CAPACITORS TO BE IN MMF IF SMALLER THAN .005 MF.

MANUAL OF 1954 MOST-OFTEN-NEEDED RADIO DIAGRAMS

TELE KING MODEL RKC 54

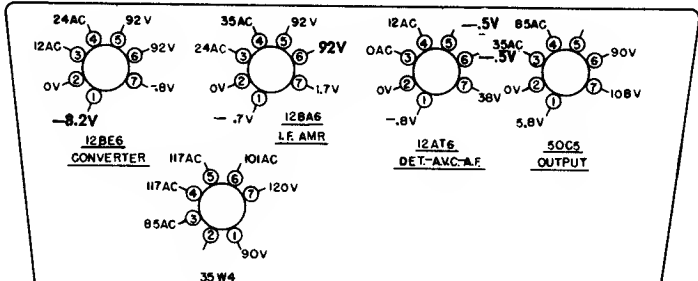
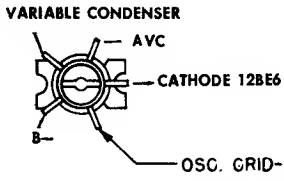
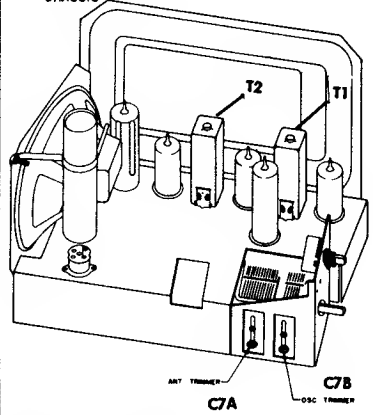
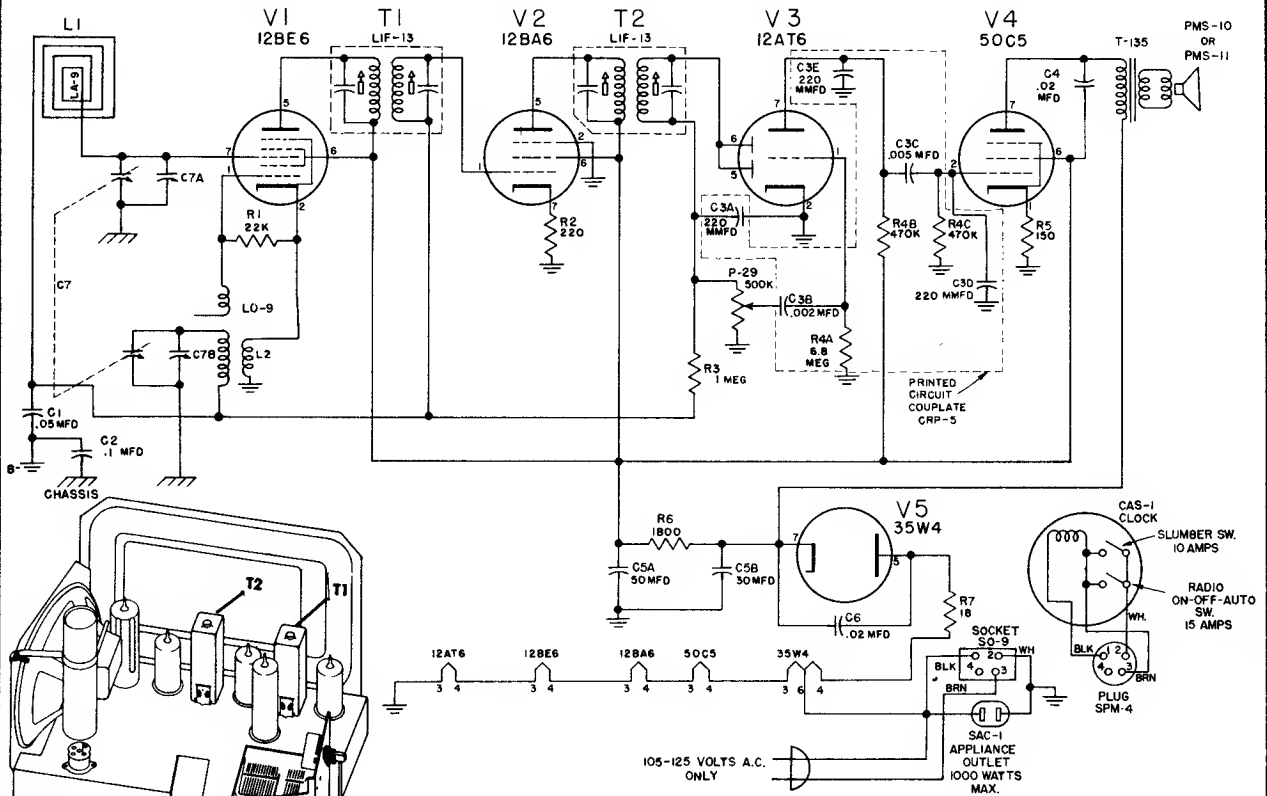

Frequency	Dummy Antenna	Connection to Radio	Position of Variable	Adjust for Maximum Output
455 KC	05	Pin 7 — 12BE6 Converter Grid	Rotor Open (Plates Out of Mesh)	T2 — Pri. and Sec.
455 KC	05	Pin 7 — 12BE6 Converter Grid	Rotor Open (Plates Out of Mesh)	T1 — Pri. and Sec.
1650 KC	05	Pin 7 — 12BE6 Converter Grid	Rotor Open (Plates Out of Mesh)	C7B — Osc. Trimmer
1500 KC		Several Turns Around Loop Ant.	1500 KC	C7A — Ant. Trimmer

MANUAL OF 1954 MOST-OFTEN-NEEDED RADIO DIAGRAMS

United Motors Buick Model 981550

(For alignment information see next page, over).

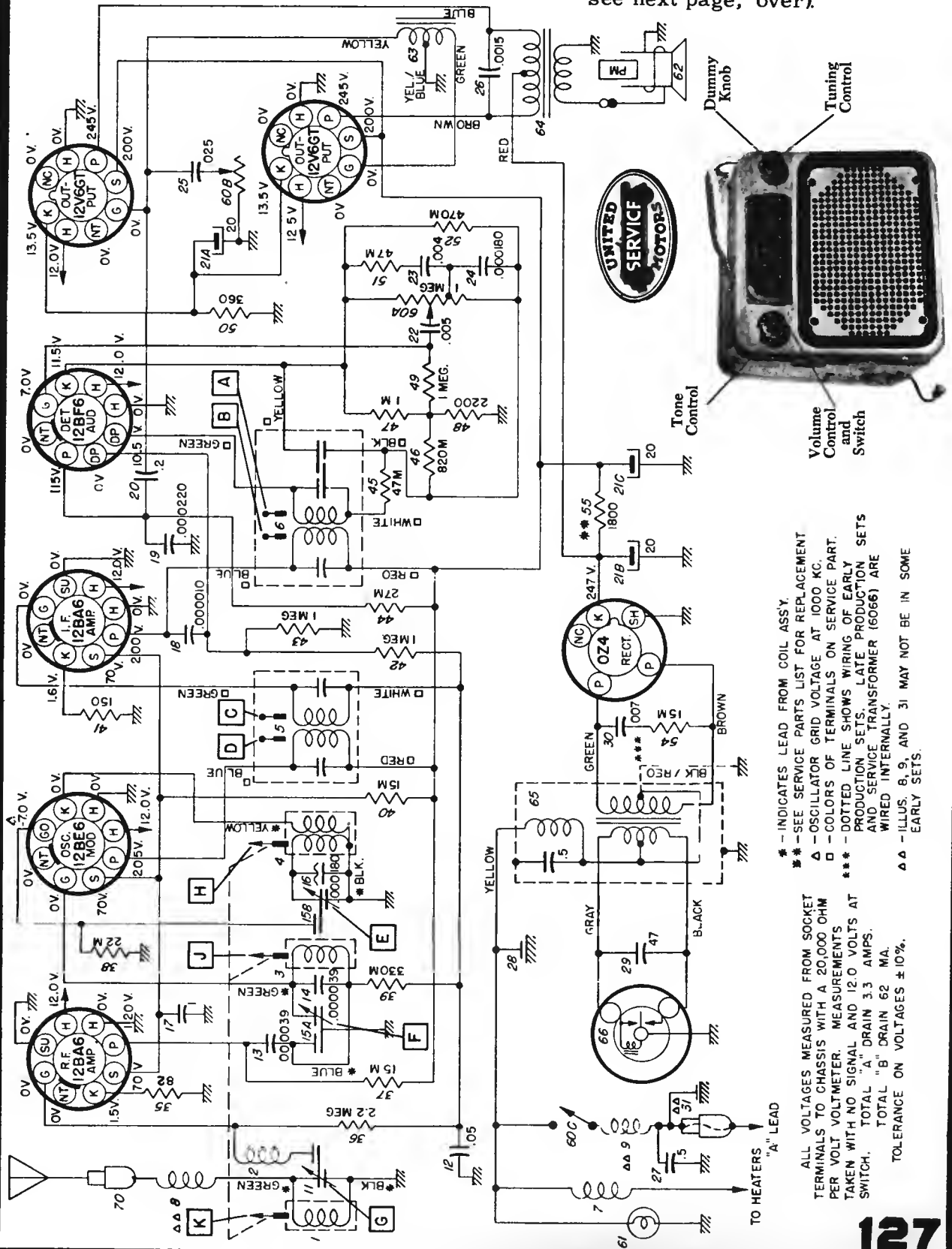

* - INDICATES LEAD FROM COIL ASS'Y
 ** - SEE SERVICE PARTS LIST FOR REPLACEMENT
 Δ - OSCILLATOR GRID VOLTAGE AT 1000 KC.
 □ - COLORS OF TERMINALS ON SERVICE PART.
 *** - DOTTED LINE SHOWS WIRING OF EARLY PRODUCTION SETS. LATE PRODUCTION SETS AND SERVICE TRANSFORMER (6066) ARE WIRED INTERNALLY.
 ΔΔ - ILLUS. B, 9, AND 31 MAY NOT BE IN SOME EARLY SETS.

ALL VOLTAGES MEASURED FROM SOCKET TERMINALS TO CHASSIS WITH A 20,000 OHM PER VOLT VOLTMETER. MEASUREMENTS TAKEN WITH NO SIGNAL AND 12.0 VOLTS AT SWITCH. TOTAL "A" DRAIN 3.3 AMPS. TOTAL "B" DRAIN 62 MA. TOLERANCE ON VOLTAGES ±10%.

MANUAL OF 1954 MOST-OFTEN-NEEDED RADIO DIAGRAMS

United Motors
Buick Model 981550
(Material continued)

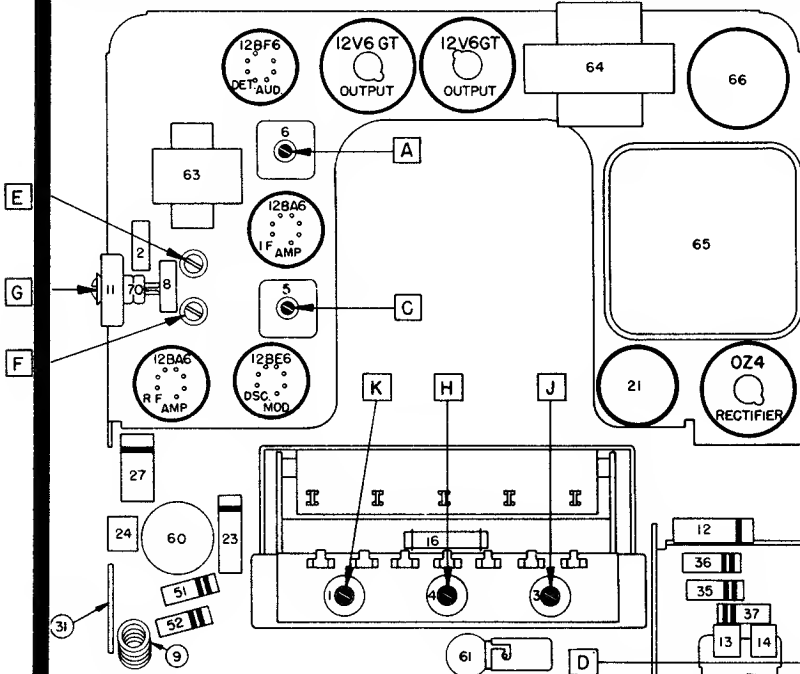

PARTS LAYOUT — TUBE VIEW

GENERAL

- MOUNTING—All 1954 Buick Cars.
- TUBES—Six, plus Rectifier.
- SPEAKER—6" x 9" Elliptical, Permanent Magnet.
- TUNING—Manual and 5 P.B. Mechanical.
- ANTENNA TRIMMER COMPENSATION—For Antennas Between 0.000050 - 0.000095 Mfd.
- TUNING RANGE—550 - 1600 KC.

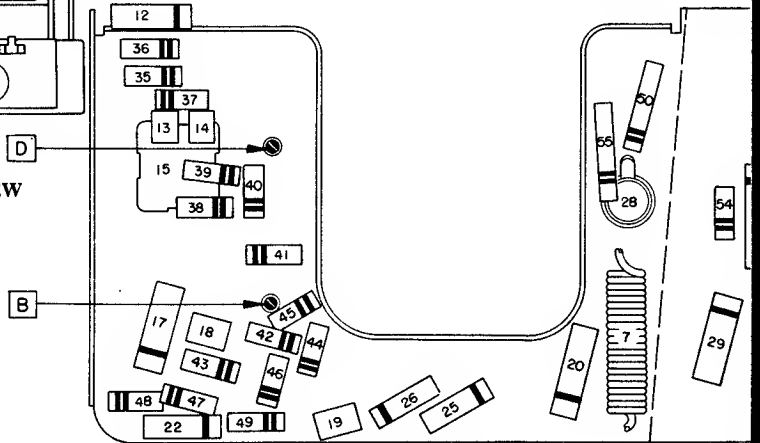

PARTS LAYOUT — CHASSIS VIEW

PUSH BUTTON SET-UP PROCEDURE

Pull Push Button to the right and out. Tune in desired station manually. Push button all the way in.

ALIGNMENT PROCEDURE

- Output Meter Connections Across Voice Coil
- Generator Return To Receiver Chassis
- Dummy Antenna In Series With Generator
- Volume Control Position Maximum Volume
- Tone Control Position Treble
- Generator Output Minimum for Readable Indication

Step	Series Condenser or Dummy Antenna	Connect Signal Generator To	Signal Generator Frequency	Tune Receiver to	Adjust in Sequence For Max. Output
1	0.1 Mfd.	12BE6 Grid (Pin #7)	262 KC	High Frequency Stop	A, B, C, D
2	.000082 Mfd.	Antenna Connector	1615 KC	High Frequency Stop	*E, F, G
3	.000082 Mfd.	Antenna Connector	1000 KC	Signal Generator Signal	J, K
4	.000082 Mfd.	Antenna Connector	1615 KC	High Frequency Stop	F, G
5	.000082 Mfd.	Antenna Connector	1000 KC	Signal Generator Signal	L**

*Before making this adjustment check mechanical setting of oscillator core "H." The rear of the core should be $1\frac{3}{32}$ " from the mounting end of the coil form. (This measurement is readily made by inserting a suitable plug in the mounting end of the coil form.) Core adjustment should be made with an insulated screwdriver, and core studs should be cemented in place with glyptal or household cement after alignment.

**L is the pointer adjustment screw which is on the connecting link, between the pointer assembly and the parallel guide bar. It should be adjusted so that the dial pointer corresponds with the 1000 KC mark on the dial. (On first "0" of "100.")

MANUAL OF 1954 MOST-OFTEN-NEEDED RADIO DIAGRAMS

UNITED MOTORS

Buick Model 981551

(Service information continued from preceding page).

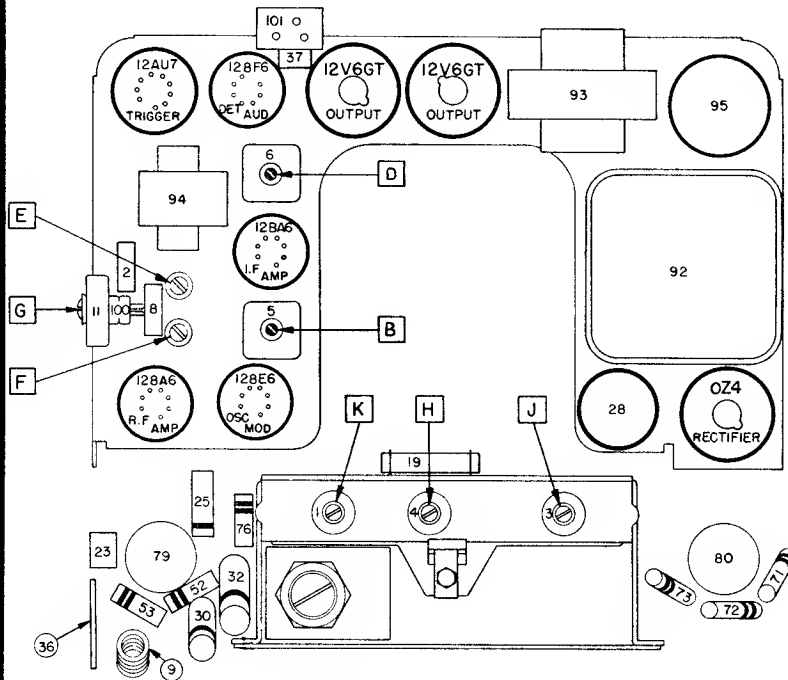

PARTS LAYOUT — TUBE VIEW

PUSH BUTTON SET-UP PROCEDURE

No push button set-up is necessary. However, the number of stations on which the tuner will stop can be controlled through use of the Sensitivity Control.

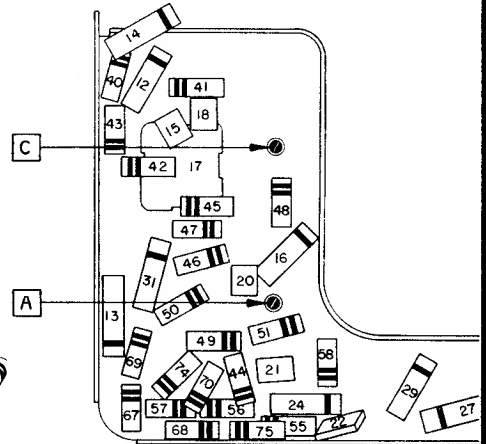

PARTS LAYOUT — CHASSIS VIEW

SIGNAL SEEKING TUNER ALIGNMENT PROCEDURE

NOTE: When aligning the signal seeker tuner type radio, be sure to use a vacuum tube voltmeter as indicated and be sure to follow the alignment sequence given—(Notice that the primary of the 2nd I.F. is aligned first.)

- Output Meter Connection VTVM from AVC Line to chassis (see parts layout.)
 Generator Return Receiver Chassis
 Dummy Antenna In Series With Generator
 Volume Control Maximum Volume
 Tone Control Treble
 Generator Output Not to exceed 2 volts at VTVM

Step	Dummy Antenna	Connect Signal Generator To	Signal Generator Frequency	Tune Receiver To	Adjust in Sequence For Output Indicated
1	0.1 Mfd.	12BE6 Grid (Pin 8)	262 KC	*High Frequency Stop	A, B, C (Max.)
2	0.1 Mfd.	12BE6 Grid (Pin 7)	262 KC	High Frequency Stop	D (Min.)
3	.000082 Mfd.	Antenna Connector	1615 KC	High Frequency Stop	**E, F, G (Max.)
4	.000082 Mfd.	Antenna Connector	600 KC	Signal Generator Signal	J, K (Max.)
5	.000082 Mfd.	Antenna Connector	1615 KC	Signal Generator Signal	F, G (Max.)
6	.000082 Mfd.	Antenna Connector	1000 KC	Signal Generator Signal	***L

*To tune to high frequency, put a 0.070" feeler gauge (or bare #13 wire) in slot against the high frequency stop. Depress station selector bar and allow the planetary arm to run against the feeler gauge. Turn the radio off and then back on.

**Before making this adjustment, check the setting of oscillator core "H." The rear of the core should be 1 3/8" from the mounting end of the coil form. This measurement is readily made by inserting a suitable plug in the mounting end of the coil form. The core adjustment is made from the mounting end of the coil form with an insulated screwdriver. (It will be necessary to steady the core guide bar while making these adjustments. This can be done by applying a downward pressure on the guide bar at the antenna coil end.) If this adjustment is necessary, first dissolve the glyptal seal on the core stud and be sure to re-seal after making the adjustment.

***"L" is the pointer adjustment screw on the end of the core guide bar—adjust so pointer reads 1000 KC.

With the radio installed and the antenna plugged in, adjust the antenna trimmer "G" for maximum volume with the radio tuned to a weak station between 600 and 1000 KC (see sticker on case.)

MANUAL OF 1954 MOST-OFTEN-NEEDED RADIO DIAGRAMS

United Motors Oldsmobile Model 983090 (Alignment data on the next page, over).

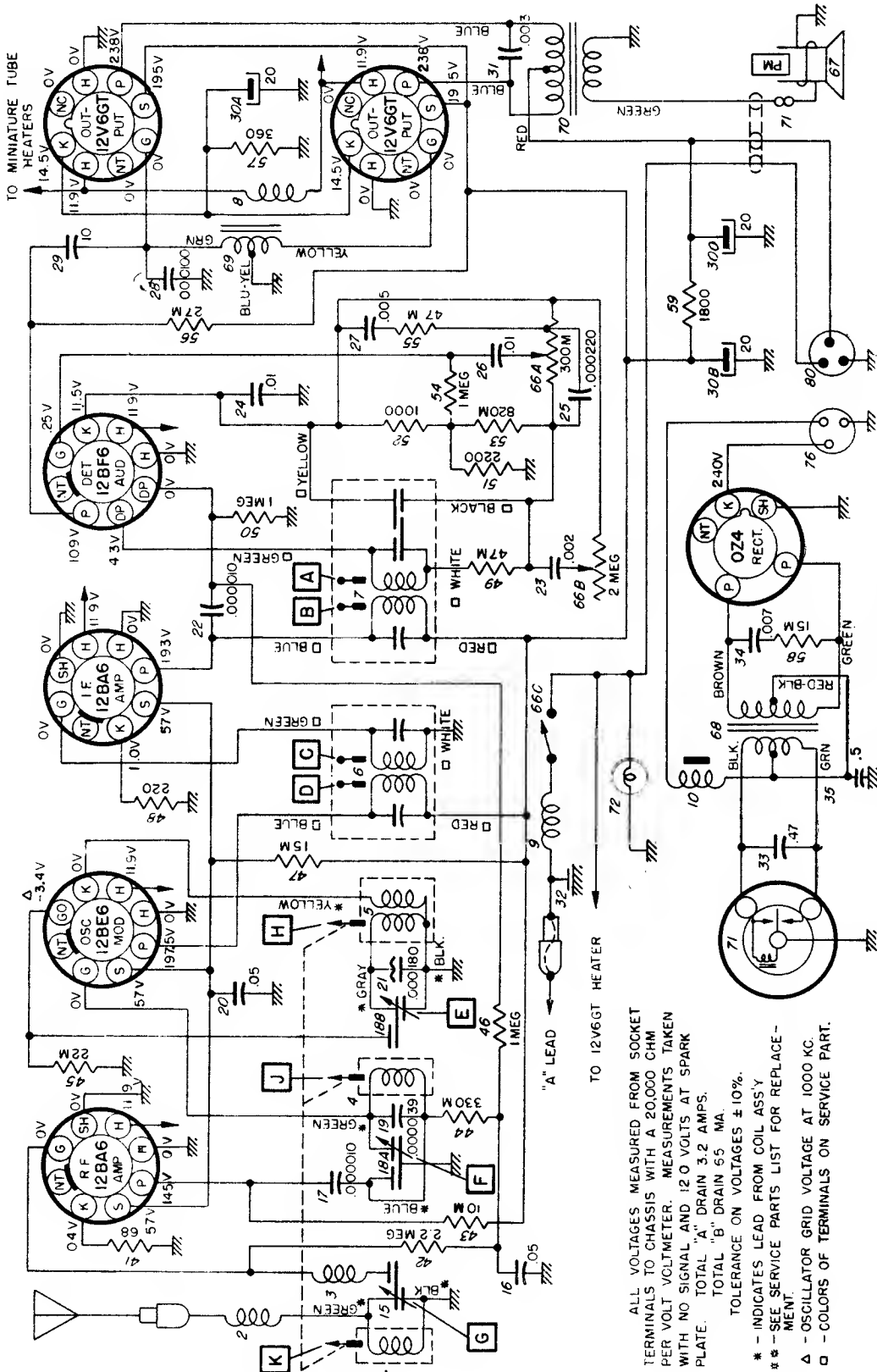

PUSHBUTTON SET-UP

Pull pushbutton to the right and out. Tune in desired station manually. Push button all the way in.

OLDSMOBILE MODEL 983090

TUNING—Manual and 5 P.B. Mechanical.

ANTENNA TRIMMER COMPENSATION

—For Antennas Between 0.000055 - 0.000073 Mfd.

TUNING RANGE—540 - 1600 KC.

ALL VOLTAGES MEASURED FROM SOCKET TERMINALS TO CHASSIS WITH A 20,000 OHM PER VOLT VOLTMETER. MEASUREMENTS TAKEN WITH NO SIGNAL AND 12.0 VOLTS AT SPARK PLATE. TOTAL "A" DRAIN 3.2 AMPS. TOTAL "B" DRAIN 55 MA.

* - INDICATES LEAD FROM COIL ASS'Y

** - SEE SERVICE PARTS LIST FOR REPLACEMENT.

Δ - OSCILLATOR GRID VOLTAGE AT 1000 KC

□ - COLORS OF TERMINALS ON SERVICE PART.

MANUAL OF 1954 MOST-OFTEN-NEEDED RADIO DIAGRAMS

United Motors
Oldsmobile
Model 983090
(Continued)



Speaker and Power Supply

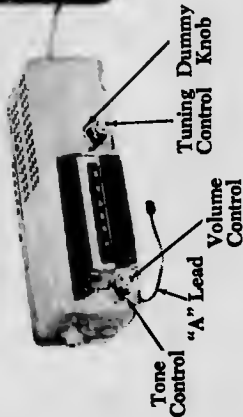

Tuning Dummy Knob

Volume Control

Tone Control

"A" Lead

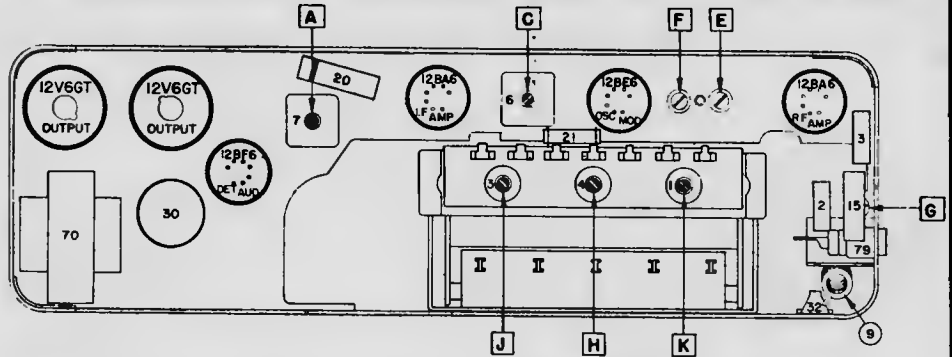

PARTS LAYOUT -- TUBE VIEW (RADIO)

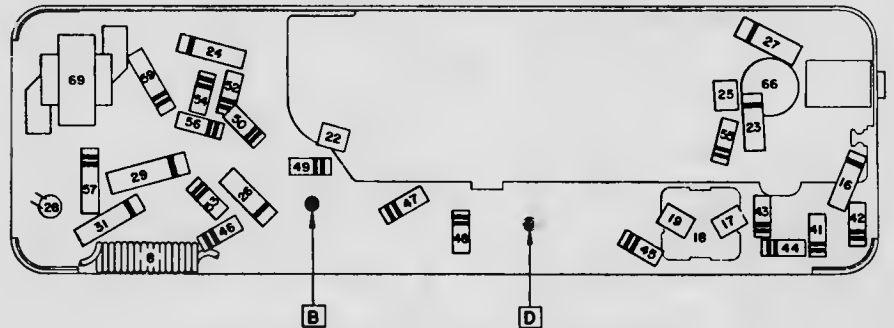

PARTS LAYOUT -- CHASSIS VIEW (RADIO)

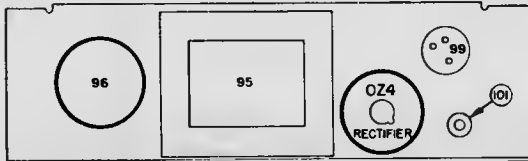

PARTS LAYOUT -- TUBE VIEW (POWER SUPPLY)

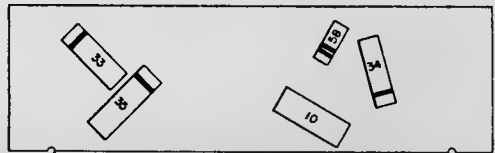

PARTS LAYOUT -- CHASSIS VIEW (POWER SUPPLY)

ALIGNMENT PROCEDURE:

Output Meter Connection Across Voice Coil
 Generator Return To Receiver Chassis
 Dummy Antenna In Series With Generator
 Volume Control Position Maximum Volume
 Tone Control Position Treble (max. clockwise)
 Generator Output Minimum for Readable Indication

Steps	Series Condenser or Dummy Antenna	Connect to	Signal Generator Frequency	Tune Receiver to	Adjust in Sequence For Max. Output
1	0.1 Mfd.	12BE6 Grid (Pin # 7)	262 KC	High Frequency Stop	A, B, C, D
2	0.000068 Mfd.	Antenna Connector	1615 KC	High Frequency Stop	*E, F, G
3	0.000068 Mfd.	Antenna Connector	1000 KC	Signal Generator Signal	J, K
4	0.000068 Mfd.	Antenna Connector	1615 KC	High Frequency Stop	F, G
5	0.000068 Mfd.	Antenna Connector	1000 KC	Signal Generator Signal	**L

*Before making this adjustment check the mechanical setting of the oscillator core "H." The slotted end of core should be 1 3/8" from the mounting end of the coil form. (This measurement is readily made by inserting a suitable plug in the mounting end of the coil form.) If adjustment is necessary, first dissolve the glyptal seal on the studs. Core adjustment should be made with an insulated screwdriver and core studs should be re-sealed in place with glyptal or household cement after alignment.

**"L" is the pointer adjustment screw which is on the pointer connecting link (see tuner drawing) and should be adjusted so the pointer reads 1000 KC. (On first "0" of "100.")

MANUAL OF 1954 MOST-OFTEN-NEEDED RADIO DIAGRAMS

United Motors Oldsmobile Model 983091 (Alignment data on the next page, over).

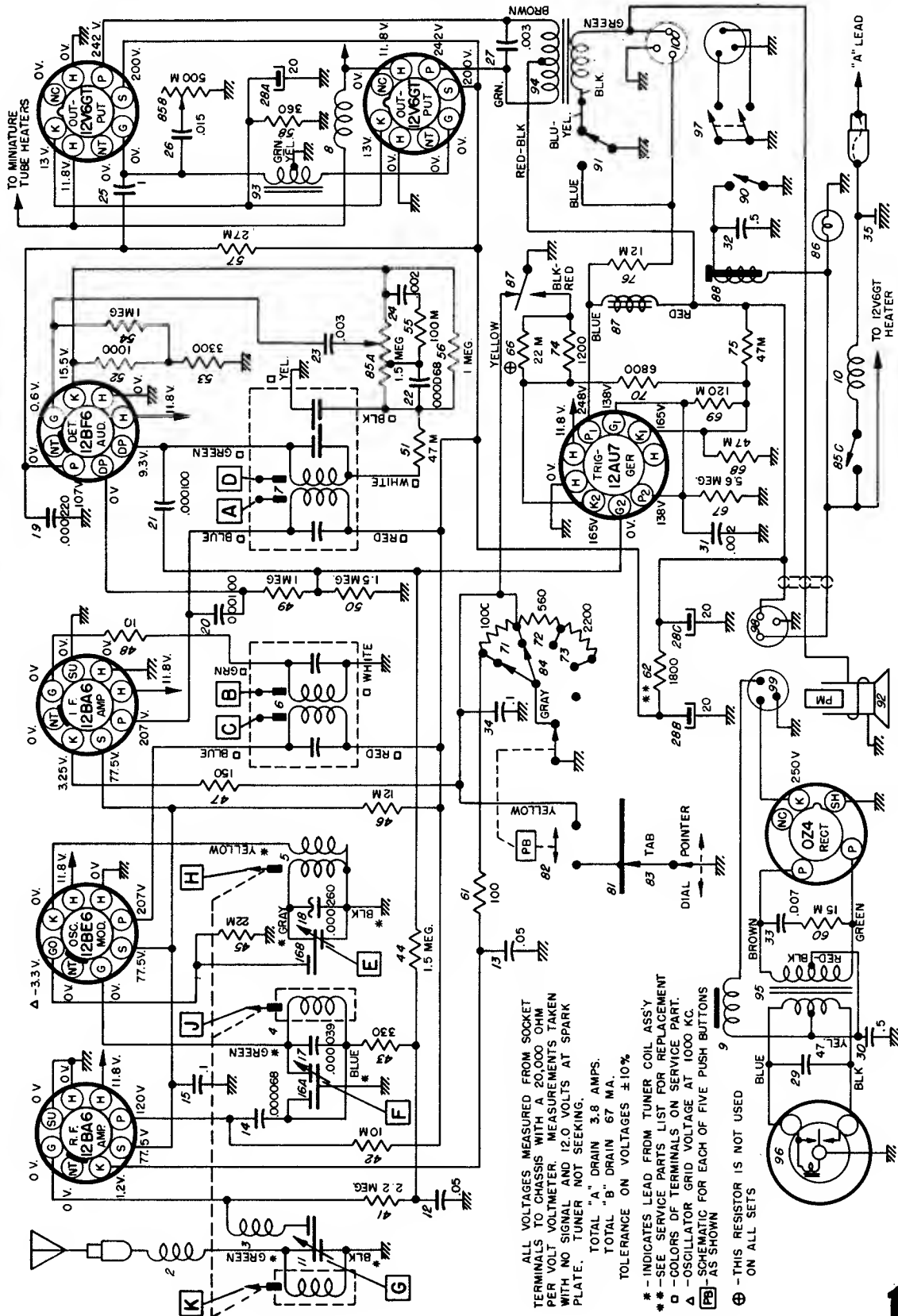

ALL VOLTAGES MEASURED FROM SOCKET TERMINALS TO CHASSIS WITH A 20,000 OHM PER VOLT VOLTMETER. MEASUREMENTS TAKEN WITH NO SIGNAL AND 12.0 VOLTS AT SPARK PLATE. TUNER NOT SEEKING.

TOTAL "A" DRAIN 3.8 AMPS.
TOTAL "B" DRAIN 67 MA.
TOLERANCE ON VOLTAGES ± 10%

* - INDICATES LEAD FROM TUNER COIL ASSY
** - SEE SERVICE PARTS LIST FOR REPLACEMENT
* - COLORS OF TERMINALS ON SERVICE PART.
Δ - OSCILLATOR GRID VOLTAGE AT 1000 KC.
[PA] - SCHEMATIC FOR EACH OF FIVE PUSH BUTTONS AS SHOWN
⊕ - THIS RESISTOR IS NOT USED ON ALL SETS

OLDSMOBILE MODEL 983091

MANUAL OF 1954 MOST-OFTEN-NEEDED RADIO DIAGRAMS

UNITED MOTORS

Oldsmobile 983091
(Continued from preceding page)

GENERAL MOUNTING—All 1954 Oldsmobile Cars.
TUBES—Six, Plus Rectifier and Trigger.
SPEAKER—8" Round Permanent Magnet.
TUNING—Electronic, Pushbutton, and Manual.—Series F-1.
ANTENNA TRIMMER COMPENSATION—For Antennas Between 0.000050 - 0.000070 Mfd.
TUNING RANGE—540 - 1600 KC.

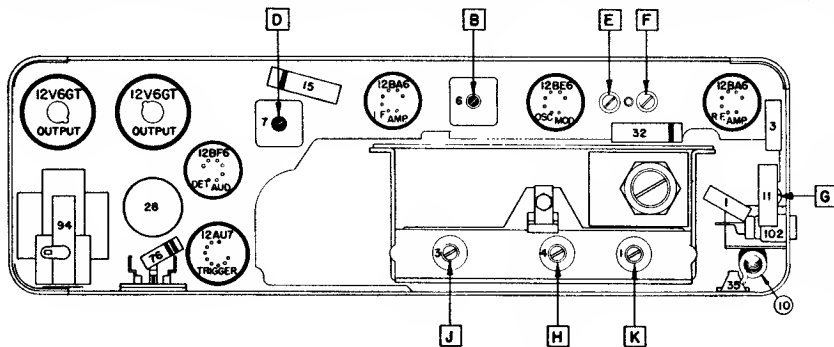

PARTS LAYOUT—TUNER VIEW

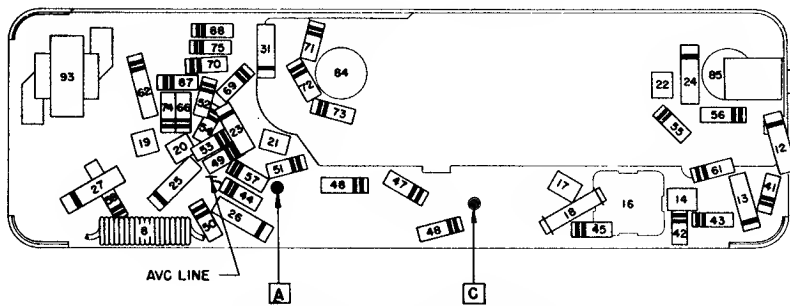

PARTS LAYOUT—CHASSIS VIEW

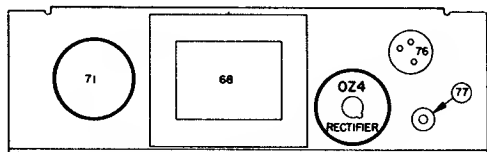

PARTS LAYOUT—TUBE VIEW

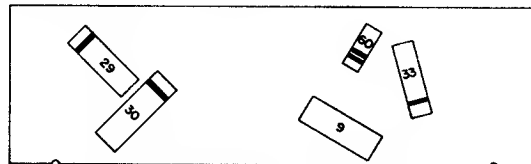

PARTS LAYOUT—CHASSIS VIEW

SIGNAL SEEKING TUNER ALIGNMENT PROCEDURE:

NOTE: When aligning the signal seeker tuner type radio, be sure to use a vacuum tube voltmeter as indicated and be sure to follow the alignment sequence given—(Notice that the primary of the 2nd I.F. is aligned first.)

- Output Meter Connection VTVM From AVC Line To Chassis (see Parts layout.)
 Generator Return Receiver Chassis
 Dummy Antenna In Series With Generator
 Volume Control Maximum Volume
 Sensitivity Control Position 2. (Position 1 is Maximum)
 Tone Control Treble (max. clockwise)
 Generator Output Not to Exceed 2 Volts at VTVM

Step	Dummy Antenna	Connect To	Signal Generator Frequency	Tune Receiver To	Adjust in Sequence
1	0.1 mfd.	12BE6 Grid (Pin 7)	262 KC	*High Frequency Stop	A, B, C (Max.)
2	0.1 mfd.	12BE6 Grid (Pin 7)	262 KC	High Frequency Stop	D (Min.)
3	0.000068 mfd.	Antenna Connector	1615 KC	High Frequency Stop	**E, F, G (Max.)
4	0.000068 mfd.	Antenna Connector	600 KC	Signal Generator Signal	J, K (Max.)
5	0.000068 mfd.	Antenna Connector	1615 KC	Signal Generator Signal	F, G (Max.)
6	0.000068 mfd.	Antenna Connector	1000 KC	Signal Generator Signal	***L

*To tune to high frequency, put a 0.070" feeler gauge (or bare #13 wire) in slot against the high frequency stop. (See tuner pictures). Turn manual control to allow the planetary arm to run against the feeler gauge.

**Before making this adjustment, check the setting of oscillator core "H." The rear of the core should be 1 1/2" from the mounting end of the coil form. This measurement is readily made by inserting a suitable plug in the mounting end of the coil form. The core adjustment is made from the mounting end of the coil form with an insulated screw driver. (It will be necessary to steady the core guide bar by applying a downward pressure at the antenna core end of the bar while making these adjustments.) If this adjustment is necessary, first dissolve the glyptal seal on the core stud and be sure to re-seal after making the adjustment.

***"L" is the pointer adjustment screw on the end of the core guide bar—adjust so pointer reads 1000 KC.

With the radio installed and the antenna plugged in, adjust the antenna trimmer "C" for maximum volume with the radio tuned to a weak station between 600 and 1000 KC (see sticker on case).

MANUAL OF 1954 MOST-OFTEN-NEEDED RADIO DIAGRAMS

United Motors Cadillac Models 7264165 and 7264185

(Continued on next page, over).

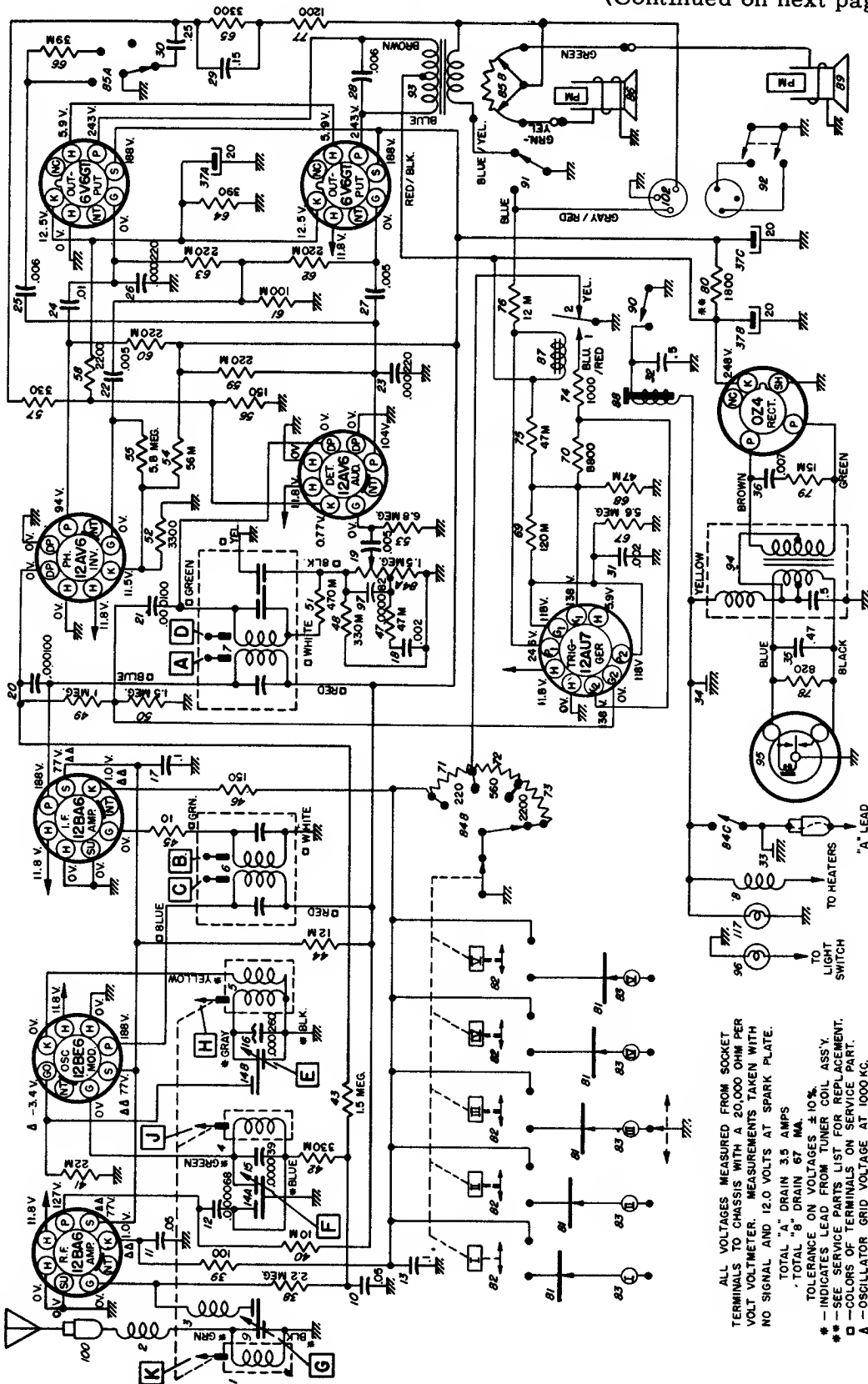

ALL VOLTAGES MEASURED FROM SOCKET TERMINALS TO CHASSIS WITH A 20,000 OHM PER VOLT VOLTMETER. MEASUREMENTS TAKEN WITH NO SIGNAL AND 12.0 VOLTS AT SPARK PLATE.
 TOTAL "A" DRAIN 3.5 AMPS
 TOTAL "B" DRAIN 67 MA.
 * - INDICATES LEAD FROM TUNER COIL ASS'Y.
 ** - SEE SERVICE PARTS LIST FOR REPLACEMENT.
 □ - COLORS OF TERMINALS ON SERVICE PART.
 A - OSCILLATOR GRID VOLTAGE AT 1000 KC.
 AA - MAXIMUM SENSITIVITY SETTING VOLTAGES.

NOTE: Illustration 85B will not be present in Model 7264185
 MODELS 7264165 and 7264185

(Model 7264195 is similar in all respects except for changes introduced because of the remote control circuit.)

MANUAL OF 1954 MOST-OFTEN-NEEDED RADIO DIAGRAMS

United Motors
Cadillac Models
7264165 and 7264185
(Continued from the
preceding page).

GENERAL

MOUNTING—Model 7264165 - All 1954 Cadillac Sedans. Model 7264185 - All 1954 Cadillac Convertibles.

TUBES—Seven, plus Rectifier and Trigger.

SPEAKER — 6" x 9" Elliptical, Permanent Magnet.

TUNING—Electronic.

ANTENNA TRIMMER COMPENSATION — 0.000060 - 0.000085 Mfd.

TUNING RANGE—540 - 1600 KC.

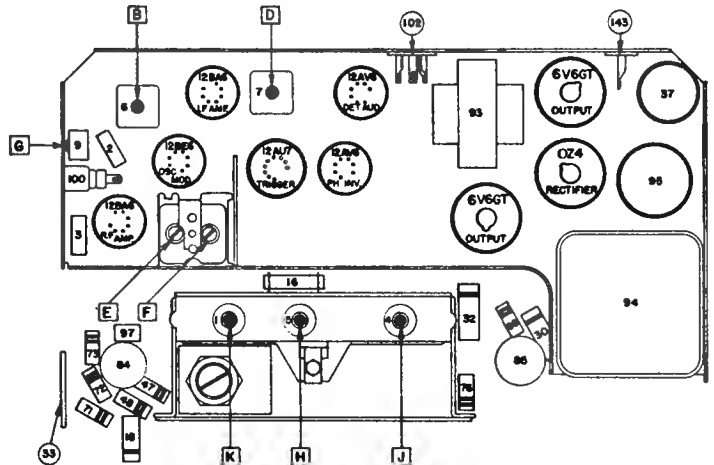

PARTS LAYOUT — TUBE VIEW

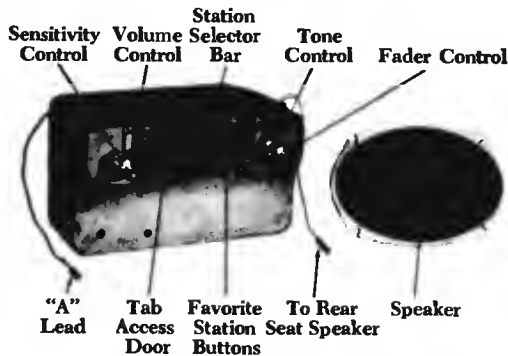

MODEL 7264165

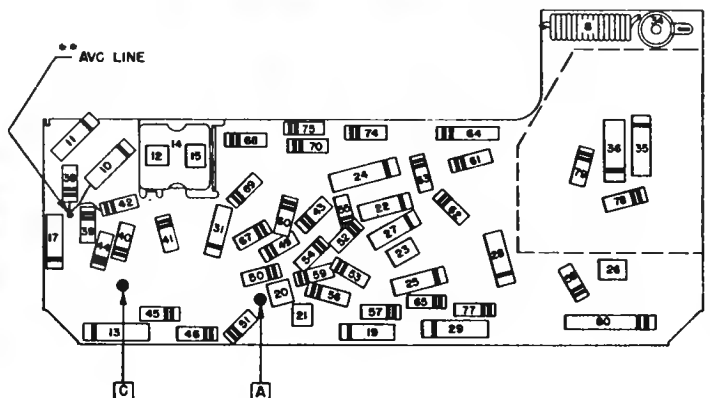

PARTS LAYOUT — CHASSIS VIEW

SIGNAL SEEKING TUNER ALIGNMENT PROCEDURE:

NOTE: When aligning the signal seeker tuner type radio, be sure to use a vacuum tube voltmeter as indicated and be sure to follow the alignment sequence given—(Notice that the primary of the 2nd I.F. is aligned first.)

Output Meter Connection VTVM From AVC Line To Chassis (see parts layout)
Generator Return Receiver Chassis
Dummy Antenna In Series With Generator
Volume Control Maximum Volume
Sensitivity Control Maximum Sensitivity
Tone Control Treble
Generator Output Not To Exceed 2 Volts at VTVM

Step	Dummy Antenna	Connect To	Signal Generator Frequency	Tune Receiver To	Adjust in Sequence for Output Indicated
1	0.1 mfd	12BE6 Grid (Pin 7)	262 KC	*High Frequency Stop	A, B, C (Max.)
2	0.1 mfd	12BE6 Grid (Pin 7)	262 KC	High Frequency Stop	D (Min.)
3	0.000088 mfd	Antenna Connector	1615 KC	High Frequency Stop	**E, F, G (Max.)
4	0.000088 mfd	Antenna Connector	600 KC	Signal Gen. Signal	J, K (Max.)
5	0.000088 mfd	Antenna Connector	1615 KC	Signal Gen. Signal	F, G (Max.)
6	0.000088 mfd	Antenna Connector	1000 KC	Signal Gen. Signal	***L

*To tune to high frequency, put a 0.070" feeler gauge (or bare # 13 wire) in slot against the high frequency stop. Depress station selector bar and allow the planetary arm to run against the feeler gauge. Turn the radio off and then on.

**Before making this adjustment, check the setting of oscillator core "H." The rear of the core should be 1 1/4" from the mounting end of the coil form. This measurement is readily made by inserting a suitable plug in the mounting end of the coil form. The core adjustment is made from the mounting end of the coil form with an insulated screwdriver. (It will be necessary to steady the core guide bar by applying a downward pressure at the antenna core end of the bar while making these adjustments.) If this adjustment is necessary, first dissolve the glyptal seal on the core stud and be sure to re-seal after making the adjustment.

***"L" is the pointer adjustment screw on the end of the core guide bar—adjust so pointer reads 1000 KC.

MANUAL OF 1954 MOST-OFTEN-NEEDED RADIO DIAGRAMS

Western Auto Supply Company

MODEL NOS. D2386, D2387, D2388

"Truetone" Model D2389 is a clock-type radio, but uses practically the identical circuit.

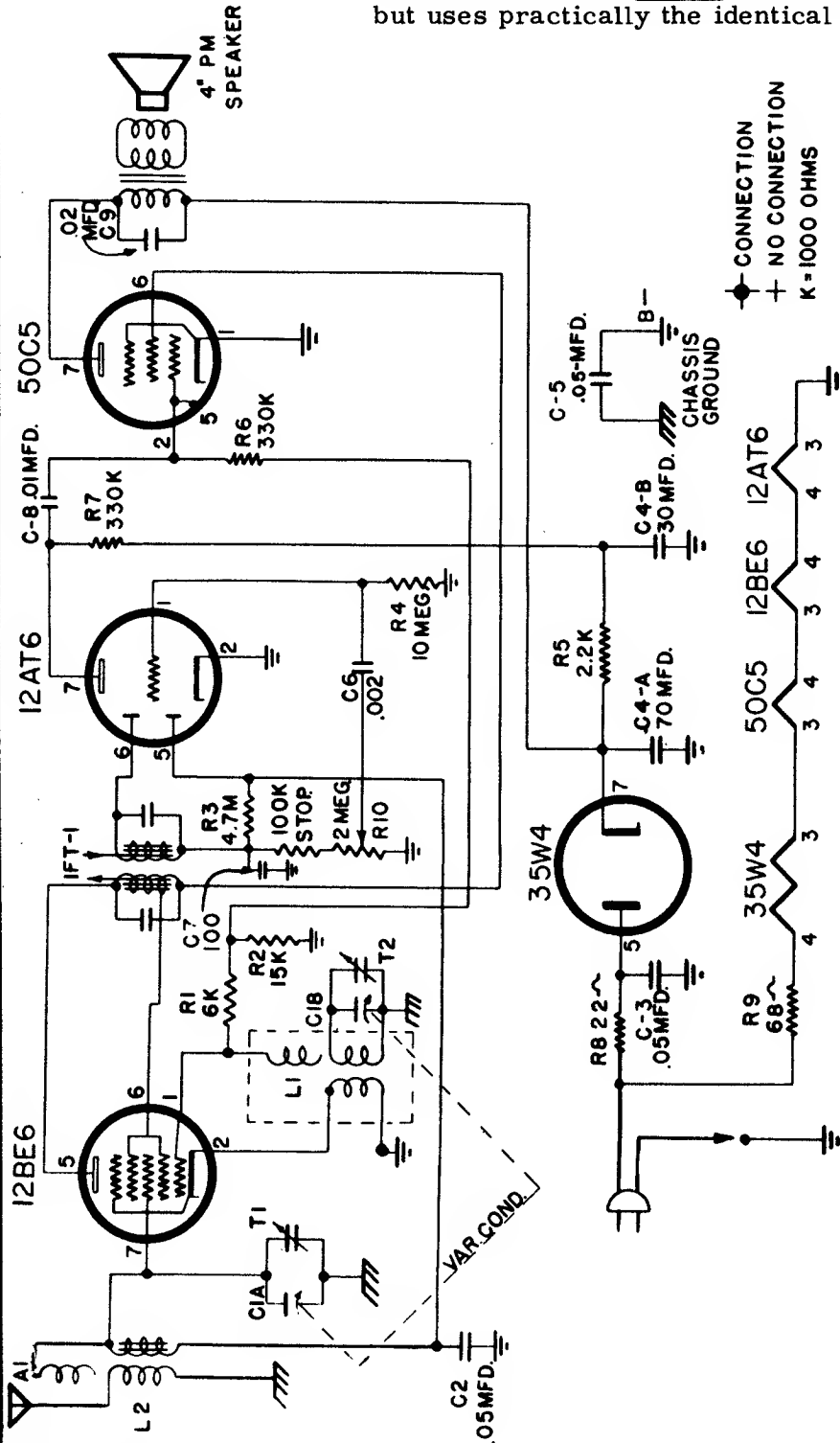

	SIGNAL GENERATOR			Trimmer Adjustments (In order shown)
	Frequency	Dummy Antenna	Ground Connection	
IF	455 kc.	.1 mfd	Grid of 12BE6 (Pin 7)	Input and Output Trimmers on i.F. Can T3 and T4
RF	1620 kc.	75 mmf	Antenna Hank	Oscillator Trimmer T2
	1400 kc.	75 mmf	Antenna Hank	Antenna Trimmer T1
	600 kc.	75 mmf	Antenna Hank	(Check Point)

MANUAL OF 1954 MOST-OFTEN-NEEDED RADIO DIAGRAMS

Western Auto Supply Company

MODEL NOS. D2410A, D2411A, D2412A, D2413A

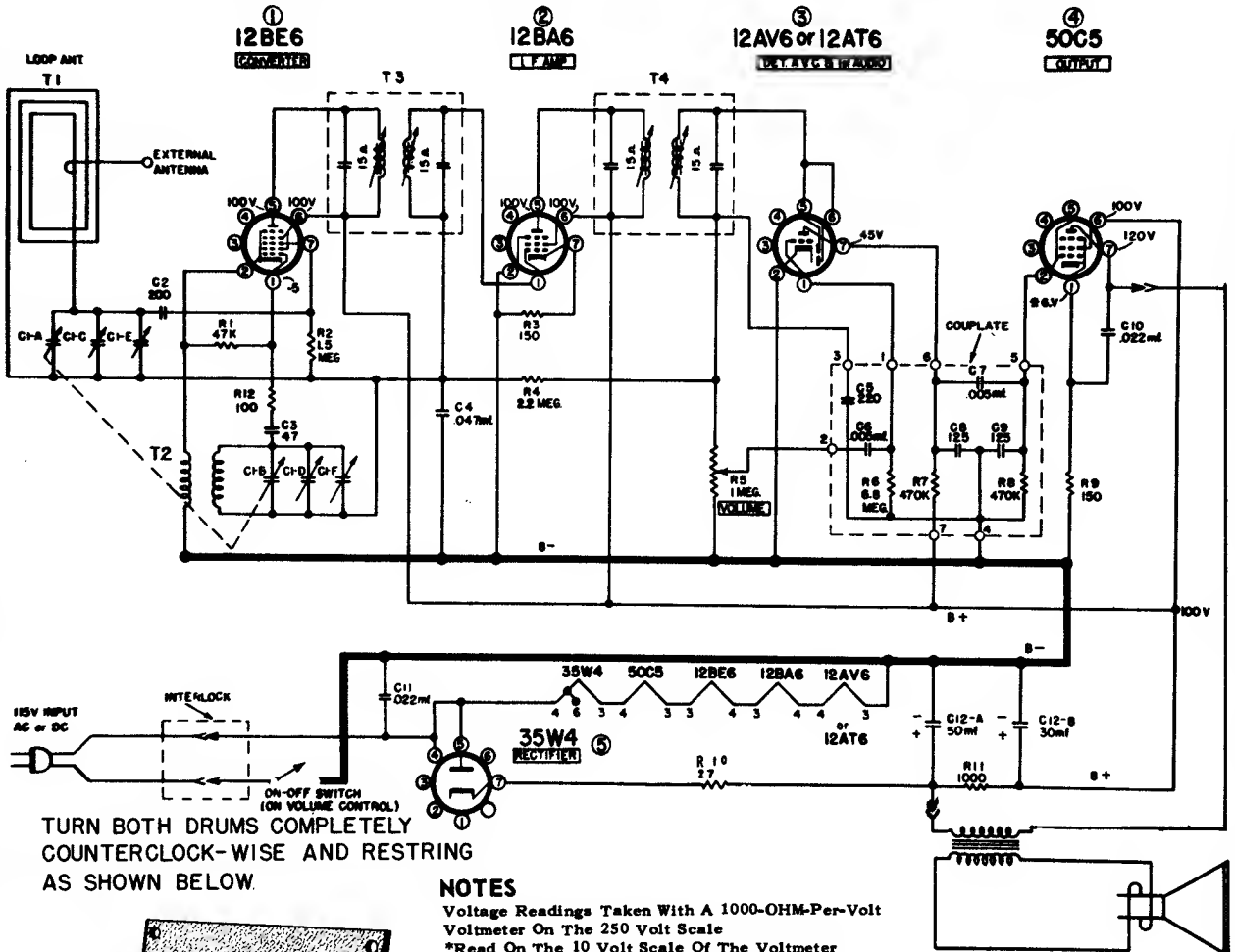

TURN BOTH DRUMS COMPLETELY COUNTERCLOCK-WISE AND RESTRING AS SHOWN BELOW.

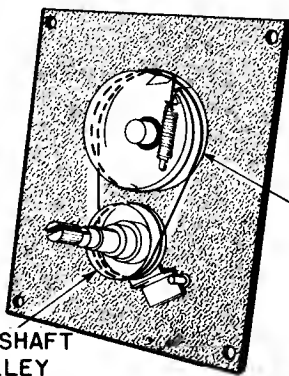

PULLEY ASSY.

TUNING SHAFT & PULLEY

NOTES

Voltage Readings Taken With A 1000-OHM-Per-Volt Voltmeter On The 250 Volt Scale
 *Read On The 10 Volt Scale Of The Voltmeter
 Line Voltage 115V. A.C.
 Unless Otherwise Shown Resistor Values Are In OHMS And Are 1/2 Watt
 Capacitor Values Are In Micro-Microfarads

ELECTRICAL SPECIFICATIONS:

Power Supply - 115 volts AC. or DC. Power consumption - 35. watts.
 Frequency Range - 535 to 1620 KC.
 I.F. Frequency - 455 KC.
 Selectivity - 40 KC. broad at 1000 times signal.
 Sensitivity (at .050 watt output) - 200 microvolt meter.
 Power Output - .7 watts undistorted, 1.5 watts Max.

ALIGNMENT PROCEDURE

SIGNAL GENERATOR				TUNER SETTING	ADJUST FOR MAXIMUM OUTPUT
FREQUENCY	COUPLING CAPACITY	CONNECTION TO RADIO	GROUND SIDE		
I.F.	455 KC	.1 mfd.	GREEN LOOP LEAD	SHELL OF LYTIC	GANG OPEN (plates out of mesh) Top and Bottom cores T4 and T3
Osc.	1620 KC	.1 mfd.	FRONT TRIMMER ON GANG	SHELL OF LYTIC	GANG OPEN (plates out of mesh) C1F Osc. trimmer on gang
Ant.	1400 KC	Connect 3 turn loop to generator place near loop on receiver		TUNE TO (1400 KC signal)	C1E Antenna trimmer on gang

MANUAL OF 1954 MOST-OFTEN-NEEDED RADIO DIAGRAMS

Western Auto Supply Company

MODEL NOS. D2418, D2419, D2420

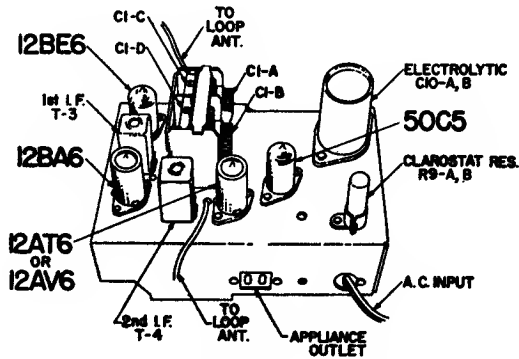

TURN DRUM COMPLETELY COUNTERCLOCK-WISE, RESTRICTING AS SHOWN.

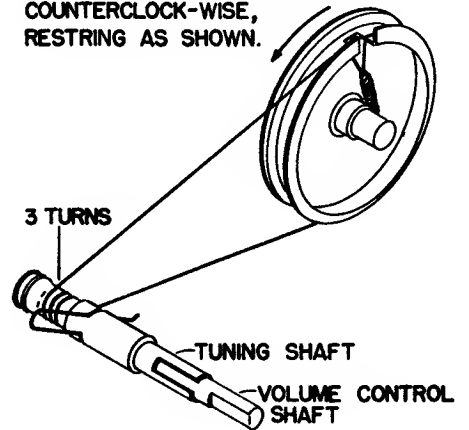

NOTE: Resistor R9A-B may be of either the Muter or Clarostat type as illustrated.

ALIGNMENT PROCEDURE

- Loop must be connected and volume set to maximum.

SIGNAL GENERATOR				TUNER SETTING	ADJUST FOR MAXIMUM OUTPUT
Frequency	Coupling Capacitor	Connection to Radio	Ground Connection		
455 kc.	.1 mf	12BE6, Pin 7	HEAVY BUSS LEAD ACROSS CENTER OF CHASSIS	Capacitor fully open (plates out of mesh)	Top and bottom Cores in output and input I.F. cans
1620 kc.	.1 mf	12BE6, Pin 7		Capacitor fully open (plates out of mesh)	Oscillator trimmer C1-D on gang
535 kc.	.1 mf.	12BE6, Pin 7		Capacitor fully closed	Check for adequate range
1400 kc.		Lay generator lead near back of cabinet		Tune in 1400 kc. signal	Antenna trimmer C-1C on gang

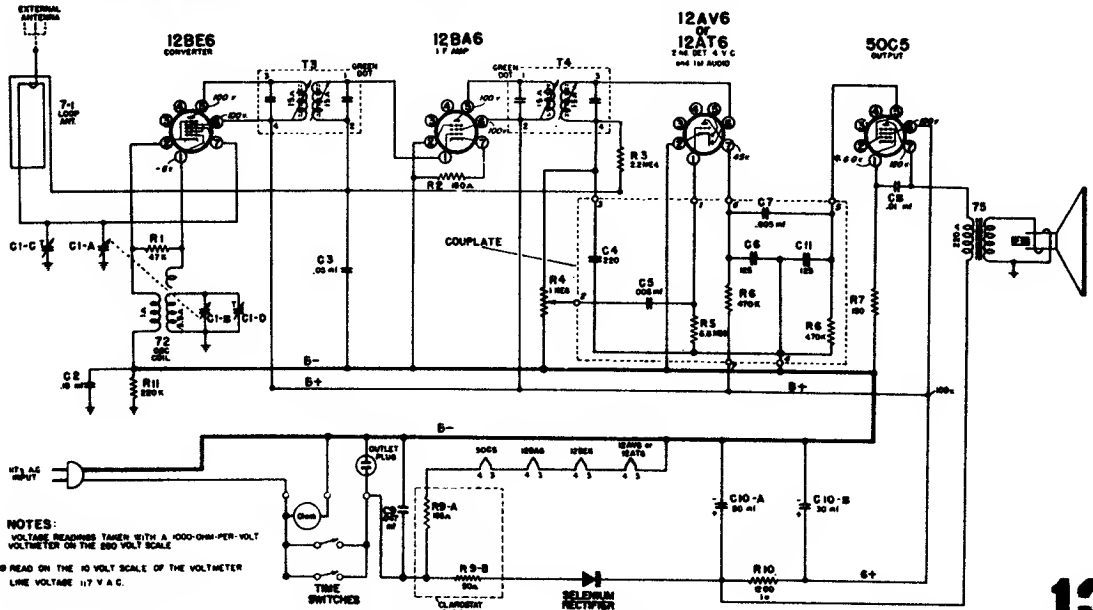

MANUAL OF 1954 MOST-OFTEN-NEEDED RADIO DIAGRAMS

Western Auto Supply Company

MODEL NO. D3300

tru-tone

BATTERY SAVER SWITCH

ON		OFF
1.5V	200 M.A.	250 M.A.
67.5V	5.4 M.A.	8.3 M.A.

Frequency Range.....532 to 1680 KCS
 Intermediate Frequency.....455 KCS
 Sensitivity.....250 microvolts per meter at 600 KCS
 Power Output.....150 milliwatts maximum
 Loud Speaker.....3" PM, V.C. impedance 3.3 ohms
 Tube Complement—1R5, Converter; 1U4, I.F. Amplifier;
 1U5, Detector, A.V.C., Audio Amplifier;
 3V4, Power Output.

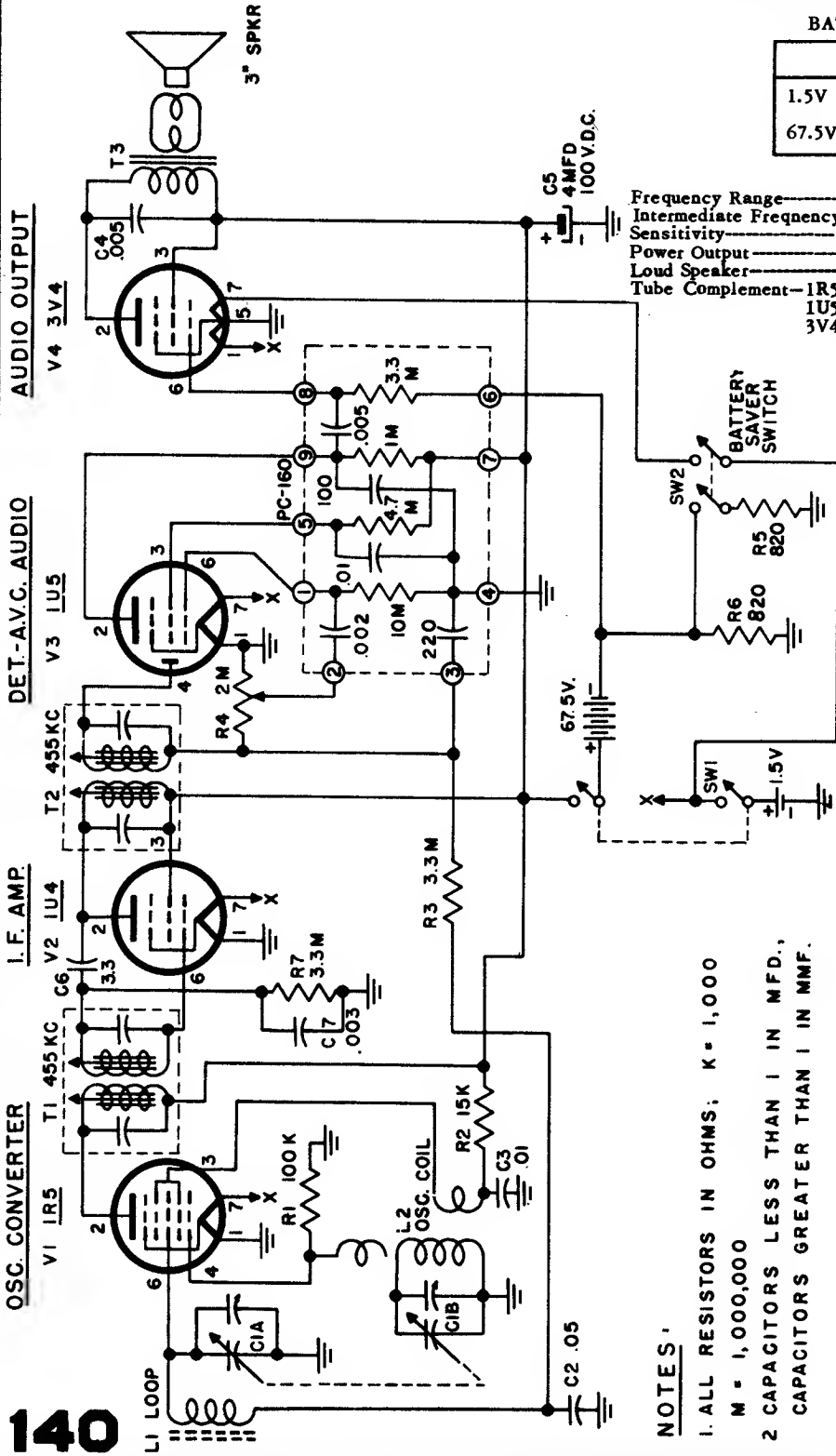

NOTES

- 1. ALL RESISTORS IN OHMS; K = 1,000
M = 1,000,000
- 2. CAPACITORS LESS THAN 1 IN MFD.,
CAPACITORS GREATER THAN 1 IN MMF.

Alignment Procedure

Output meter across voice coil (3.3 ohms)
 Volume control at maximum
 Align for maximum output.
 Reduce input as needed to keep output at
 0.4 volts (50 mw)

Frequency	Signal Generator	Connections To Receiver	Ground Connection	Adjust Trimmer To Maximum Output
I.F. 455kc	Coupling Capacitor 0.1mfd	12BE6 grid	chassis	Input and Output I.F. Slugs
OSC. 1650kc	0.1mfd	12BE6 grid	chassis	Oscillator Trimmer
ANT. 1500kc		Radiating Loop		Antenna Trimmer
				Tuner Setting
				Full Capacitance (plates in full mesh)
				Minimum Capacitance (Plates out of mesh)
				1500kc

MANUAL OF 1954 MOST-OFTEN-NEEDED RADIO DIAGRAMS

Western Auto Supply Company

MODEL D3351-RED; D3352-GRAY; D3353-GREEN

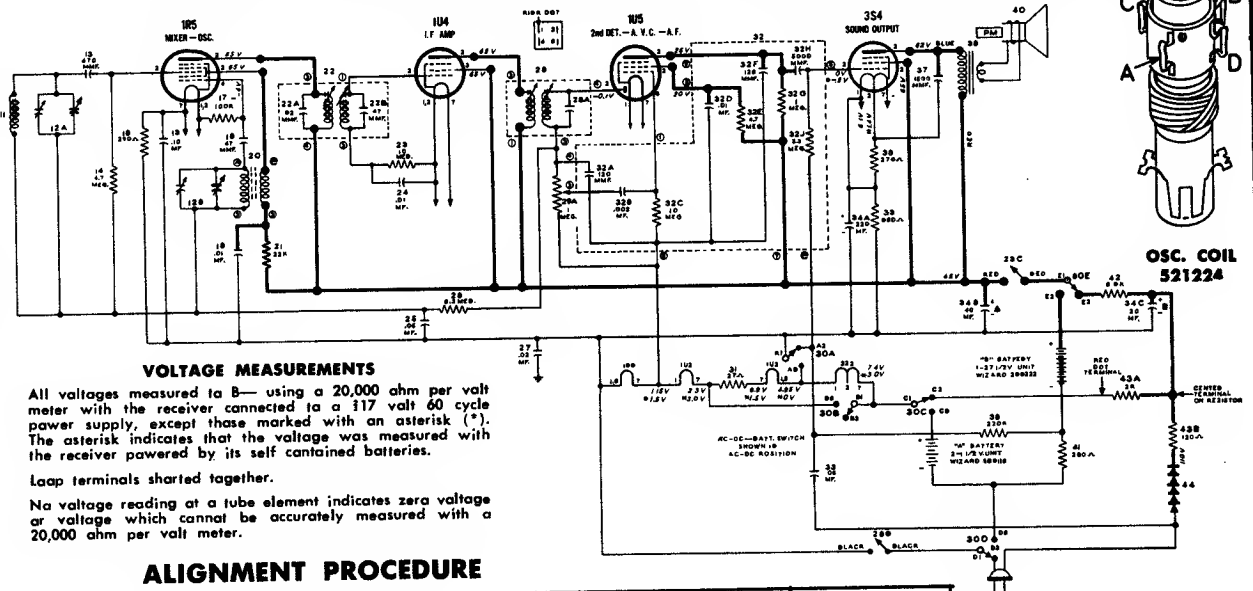

ALIGNMENT PROCEDURE

SIGNAL GENERATOR CONNECTIONS		SIGNAL GENERATOR FREQUENCY	RECEIVER DIAL SETTING	TRIMMER OR SLUG NUMBER	TRIMMER DESCRIPTION	TYPE OF ADJUSTMENT
CONNECT HIGH SIDE OF SIGNAL GENERATOR TO	CONNECT GROUND LEAD OF SIGNAL GENERATOR TO					
Lug an trimmer #6 at side of gang (see chart below for location of trimmer).	Any B— terminal in chassis. CAUTION If your signal generator is designed with an AC-DC type power supply, connect ground lead of signal generator to receiver through a .25 Mfd. condenser.	455 KC	Any point where it does not affect the signal.	1 and 2	2nd I.F.	Adjust for maximum output. Then repeat adjustment.
				3 and 4	1st I.F.	
<p>IMPORTANT: Before undertaking alignment of the oscillator and antenna trimmers it is necessary to reassemble the chassis in the cabinet. The tuning knob should be installed on the gang condenser shaft so that when the condenser is fully meshed, the dot under the smaller 5 of the 55 an dial scale is directly opposite the pointer (gold mark on cabinet). As battery position slightly affects R.F. alignment, it is preferable to have batteries in proper place. To gain access to oscillator and antenna trimmers, it will be necessary to open back of cabinet. In order to provide a coupling for the signal generator, during this part of the procedure, wind several turns of wire in a circular shape to form a radiating loop that may be placed adjacent (axes parallel) to the loop antenna. Now complete the alignment procedure as follows.</p>		1600 KC	1600 KC	5	Broadcast Oscillator	Adjust for maximum output.
Connect directly to radiating loop. (See above for instructions on radiating loop.) Rotate and adjust loop for maximum input.		1500 KC	Tune to 1500 Kc. generator signal.	6	Broadcast Antenna	Adjust for maximum output.
Same as above.						

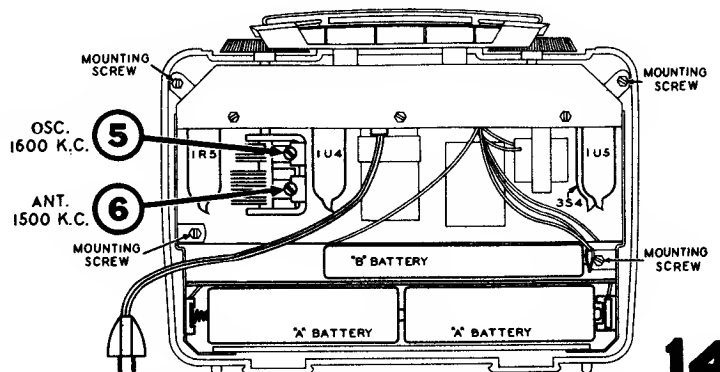
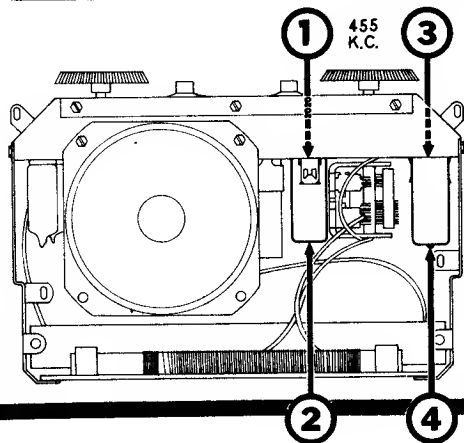

MANUAL OF 1954 MOST-OFTEN-NEEDED RADIO DIAGRAMS

Western Auto Supply Company MODEL NO. D3465A

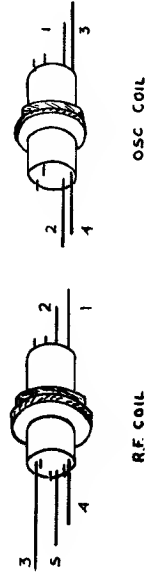
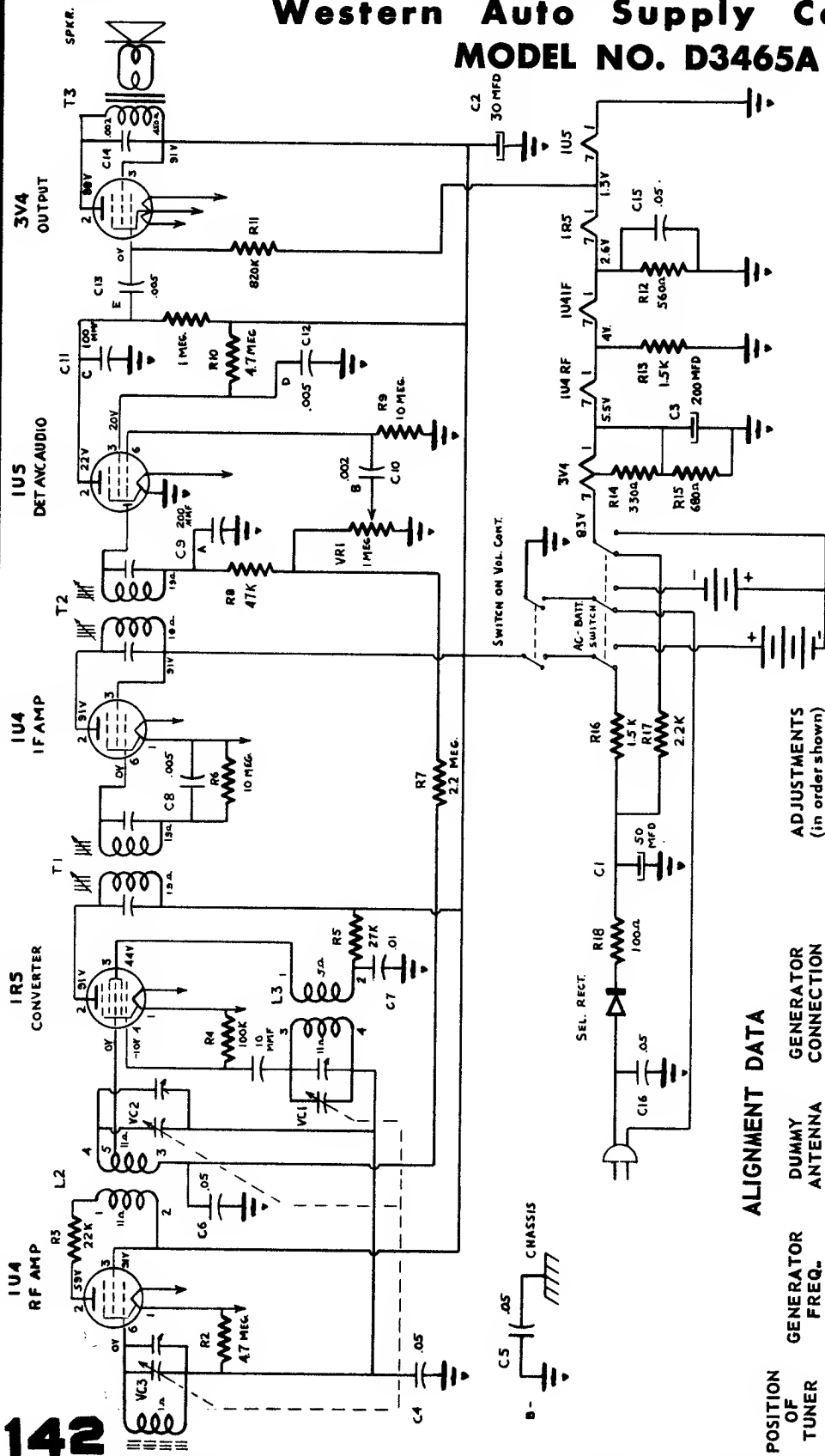

ALIGNMENT DATA

POSITION OF TUNER	GENERATOR FREQ.	DUMMY ANTENNA	GENERATOR CONNECTION	ADJUSTMENTS (in order shown)
Min. Cap.	455 kc	0.1 mfd.	Pin #6 of IUS Conv.	T2 Top & Bottom T1 Top & Bottom
Min. Cap.	1610 kc	0.1 mfd.	Stator ant. tuner (C4)	VC1 Trimmer
1400 kc	1400 kc	0.1 mfd.	Stator ant. tuner (C4)	VC2 Trimmer
1400 kc	1400 kc	Loosely coupled to loop		VC3 Trimmer

MANUAL OF 1954 MOST-OFTEN-NEEDED RADIO DIAGRAMS

Western Auto

MODEL NOS.

D2584, D2585

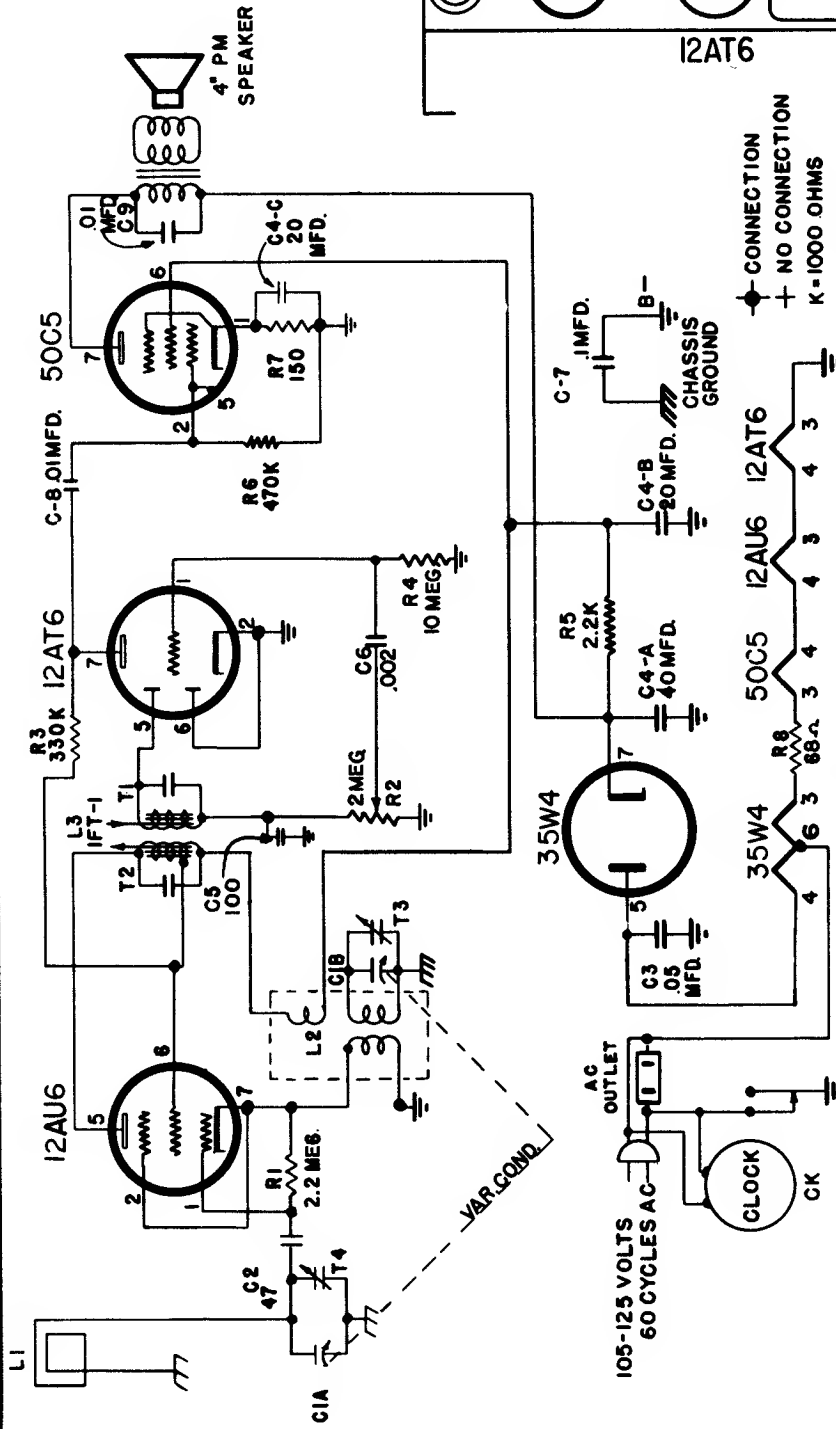
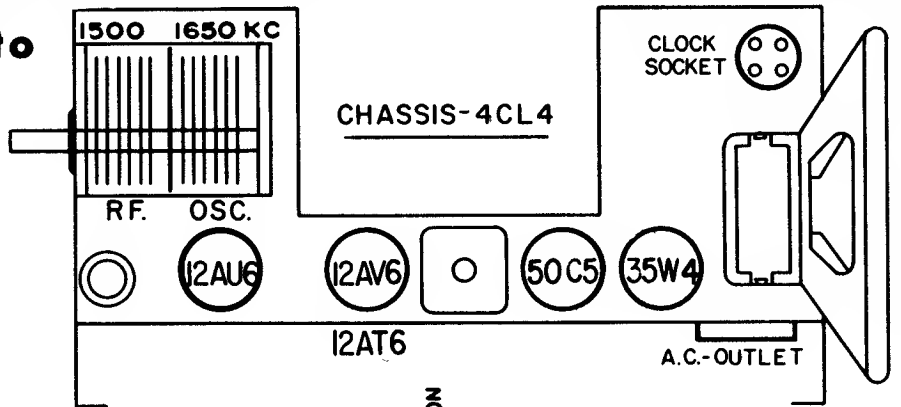

POSITION OF VARIABLE	SIGNAL GENERATOR DUMMY CONNECTION TO RECEIVER		TRIMMER ADJUSTMENTS (in order shown)
	FREQUENCY	ANTENNA CONNECTION	
IF	455 kc.	.1 mfd.	Stator of RF section of var. condenser
RF	1650 kc.		Stator of RF section of var. condenser
	1500 kc.		Oscillator Trimmer T3
	600		RF Trimmer T4
			Check Point

Fashion loop of several turns of wire and radiate sig. into loop of receiver adj. for max. output.

MANUAL OF 1954 MOST-OFTEN-NEEDED RADIO DIAGRAMS

Western Auto Supply Company

MODEL NO. D4320 B

REMOVING CHASSIS FROM CASE

The Chassis can be removed to permit service of Major Components, such as Vibrator, tubes, Capacitors, Resistors etc., by removing 3 Hex Head Mtg. screws, and disconnecting the Speaker leads and sliding the chassis out of the housing.

NOTE: VOLTAGE READINGS TAKEN WITH A GOOD OHM PLOT METER BETWEEN POINTS SHOWN AND CHASSIS. VALUES ARE IN OHMS UNLESS OTHERWISE INDICATED. CAPACITOR VALUES ARE IN MICRO-MICRO FARADS.

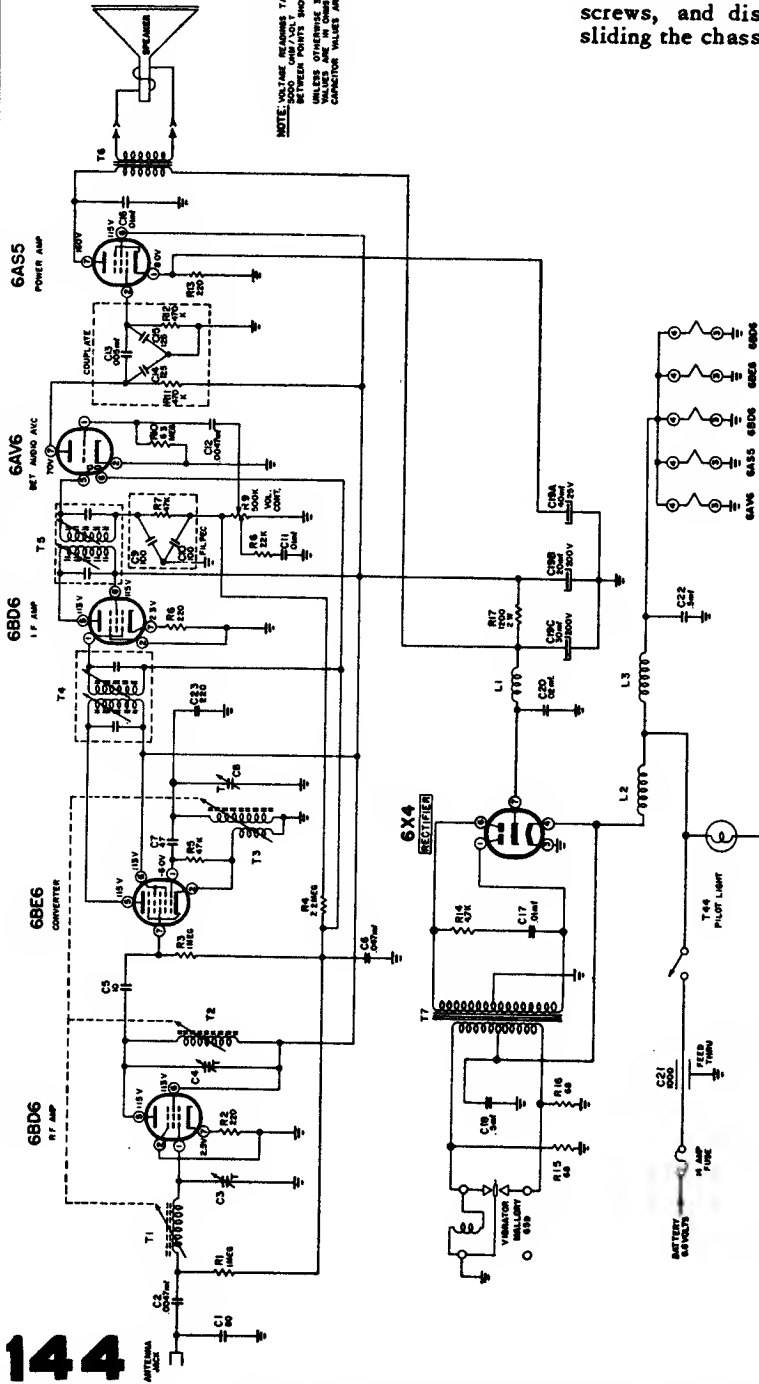

ALIGNMENT PROCEDURE

Connect an output meter to the speaker leads. The output meter should present a load of 3.2 ohms. Connect the ground lead of the signal generator to the chassis base.

IF ALIGNMENT:

1. Connect the hot lead of the signal generator through a .10 mfd. capacitor to Pin 7 of the converter (6BE6) tube. Apply a 400 cycle, 30% modulated carrier of 455 KC at about 150 microvolts.
2. Set the volume control at maximum and adjust the top and bottom cores of the first and second IF transformers (T4 and T5) for maximum output, as indicated on the output meter. Keep signal generator level low.

RF ALIGNMENT:

1. Set the signal generator to 1620KC and turn tuning control fully counter-clockwise.
 2. Adjust oscillator trimmer C8 for maximum deflection.
 3. Disconnect the hot signal generator lead and .10 mfd. capacitor and reconnect to the antenna jack through a 50 mmf capacitor.
 4. Set the signal generator to 1300 KC and tune in the receiver for maximum reading on output meter. Keep signal generator level low.
 5. Adjust antenna and R.F. trimmers C3 and C4 for maximum reading.
- The tuner cores are adjusted and sealed at the factory, therefore core adjustments are not necessary.

MANUAL OF 1954 MOST-OFTEN-NEEDED RADIO DIAGRAMS

Westinghouse CHASSIS ASSEMBLY V-2189-2

MODELS H-434T5 H-435T5 H-436T5 H-437T5 H-438T5

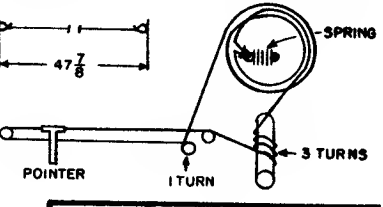
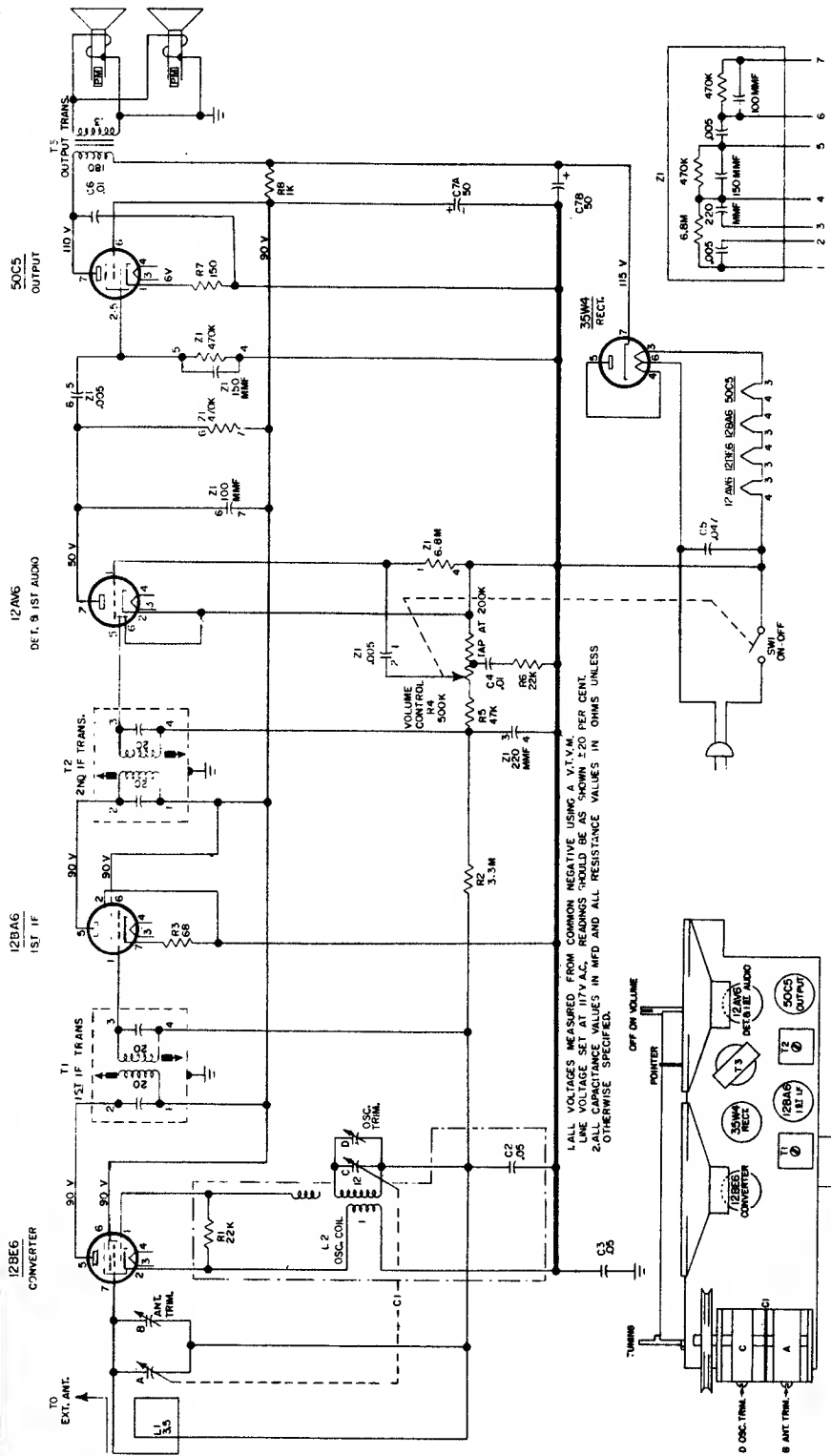

ALIGNMENT

Step	Connect Signal Generator to -	Signal Generator Frequency	Radio Dial	Adjust for Maximum Output -
1.	Stator of ant. tuning capacitor (A) through a 200 muf capacitor	455 kc.	Minimum capacity	Top and bottom slugs of T2 and T1 in order given
2.	Same as Step 1	1625 kc.	Minimum capacity	Oscillator trimmer (D)
3.	Radiated signal	1400 kc.	1400 kc.	Antenna trimmer (B)

MANUAL OF 1954 MOST-OFTEN-NEEDED RADIO DIAGRAMS

Westinghouse Models H-405P5 and H-406P5 Chassis V-2156-2

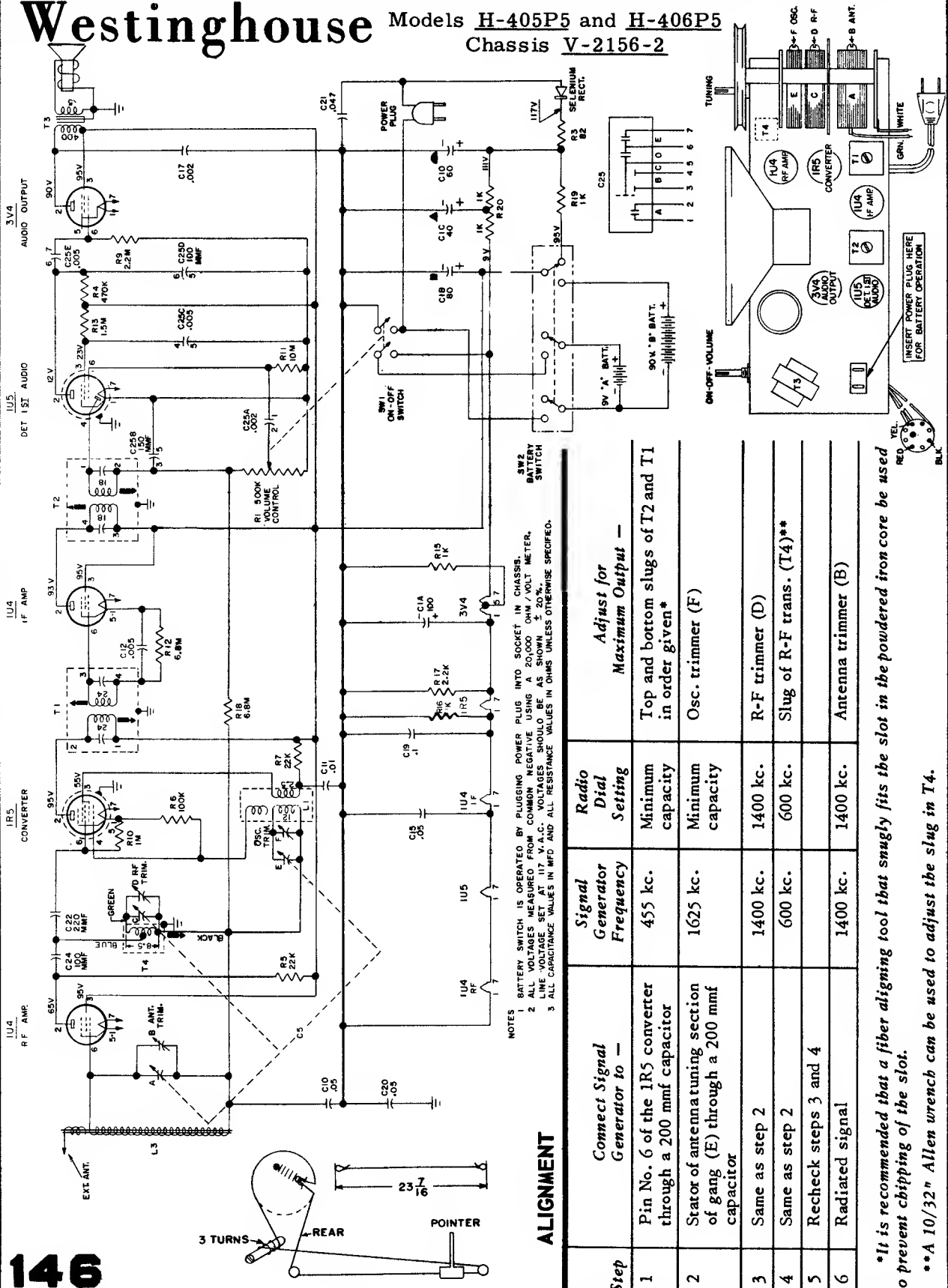

NOTES
 1 BATTERY SWITCH IS OPERATED BY PLUGGING POWER PLUG INTO SOCKET IN CHASSIS.
 2 ALL VOLTAGES MEASURED FROM COMMON NEGATIVE USING A 20000 OHM / VOLT METER.
 LINE VOLTAGE SET AT 117 V.A.C. VOLTAGES SHOULD BE ADJUSTED TO CORRECT VALUES.
 3 ALL CAPACITANCE VALUES IN MFD. AND ALL RESISTANCE VALUES IN OHMS, UNLESS OTHERWISE SPECIFIED.

ALIGNMENT

Step	Connect Signal Generator to —	Signal Generator Frequency	Radio Dial Setting	Adjust for Maximum Output —
1	Pin No. 6 of the IRS converter through a 200 mmf capacitor	455 kc.	Minimum capacity	Top and bottom slugs of T2 and T1 in order given*
2	Stator of antenatuning section of gang (E) through a 200 mmf capacitor	1625 kc.	Minimum capacity	Osc. trimmer (F)
3	Same as step 2	1400 kc.	1400 kc.	R-F trimmer (D)
4	Same as step 2	600 kc.	600 kc.	Slug of R-F trans. (T4)**
5	Recheck steps 3 and 4			
6	Radiated signal	1400 kc.	1400 kc.	Antenna trimmer (B)

*It is recommended that a fiber aligning tool that snugly fits the slot in the powdered iron core be used to prevent chipping of the slot.

**A 10/32" Allen wrench can be used to adjust the slug in T4.

MANUAL OF 1954 MOST-OFTEN-NEEDED RADIO DIAGRAMS

Westinghouse

Models H-391T5, H-392T5, H-394T5,
and H-404T5, Chassis V-2157-14.

Similar Models are H-420T5, H-421T5, using Chassis V-2157-13.

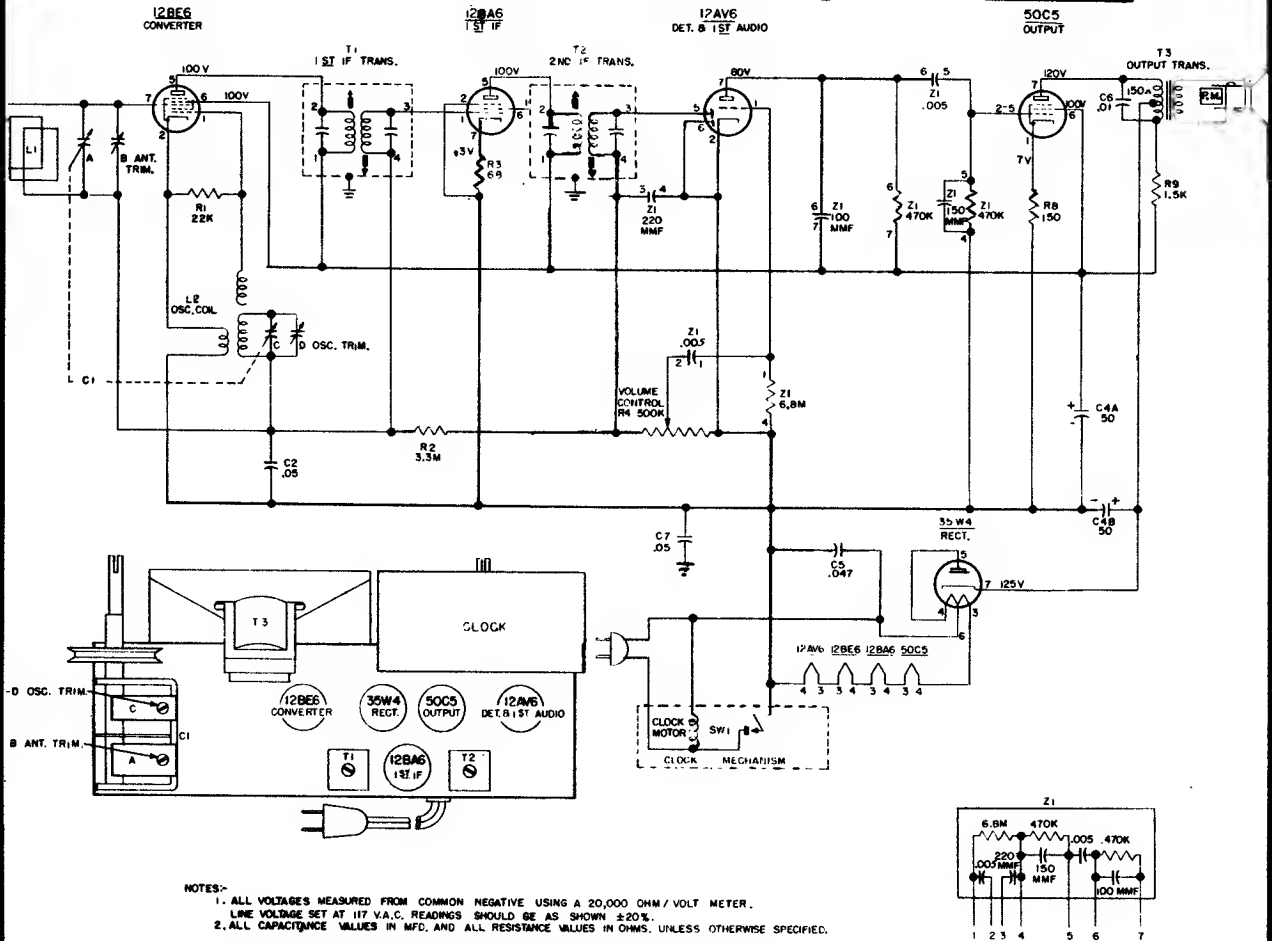

REMOVAL OF CHASSIS FROM CABINET

1. Remove the four control knobs by pulling them off the shafts.
2. Remove the transparent shield which protects the radio dial pointer by pressing the left edge (as viewed from the front) toward the hub of the dial pointer. This unlocks the shield from the cabinet.
3. Pull the dial pointer off its shaft.
4. Remove the two screws from the bottom of the cabinet, and slide out the chassis.

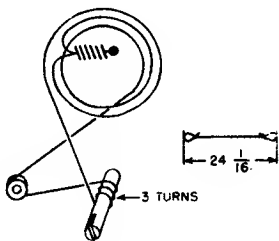

ALIGNMENT

Step	Connect Signal Generator to —	Signal Generator Frequency	Radio Dial	Adjust for Maximum Output
1	Stator of ant. tuning capacitor (A) through a 200 mmf capacitor	455 kc.	Minimum capacity	Top and bottom slugs of T2 and T1 in order given*
2	Same as step 1	1625 kc.	Minimum capacity	Oscillator trimmer (D)
3	Radiated signal	1400 kc.	1400 kc.	Antenna trimmer (B)

*It is recommended that a fiber aligning tool that snugly fits the slot in the powdered iron core be used to prevent chipping of the slot.

MANUAL OF 1954 MOST-OFTEN-NEEDED RADIO DIAGRAMS

WESTINGHOUSE Chassis V-2182-2
 Models H-414P4, H-415P4, H-461P4,
H-462P4, H-463P4, H-464P4, H-479P4.

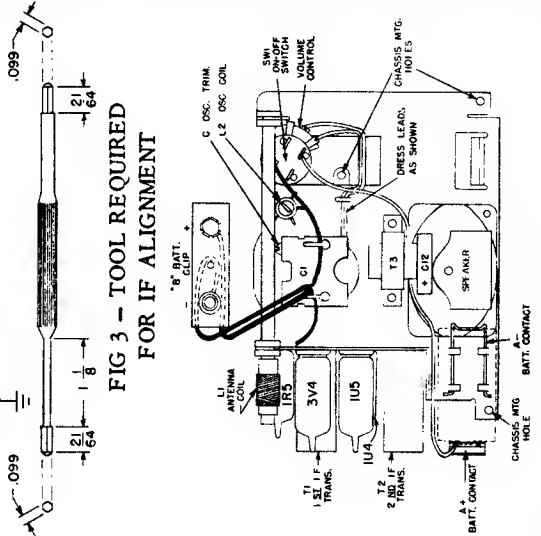
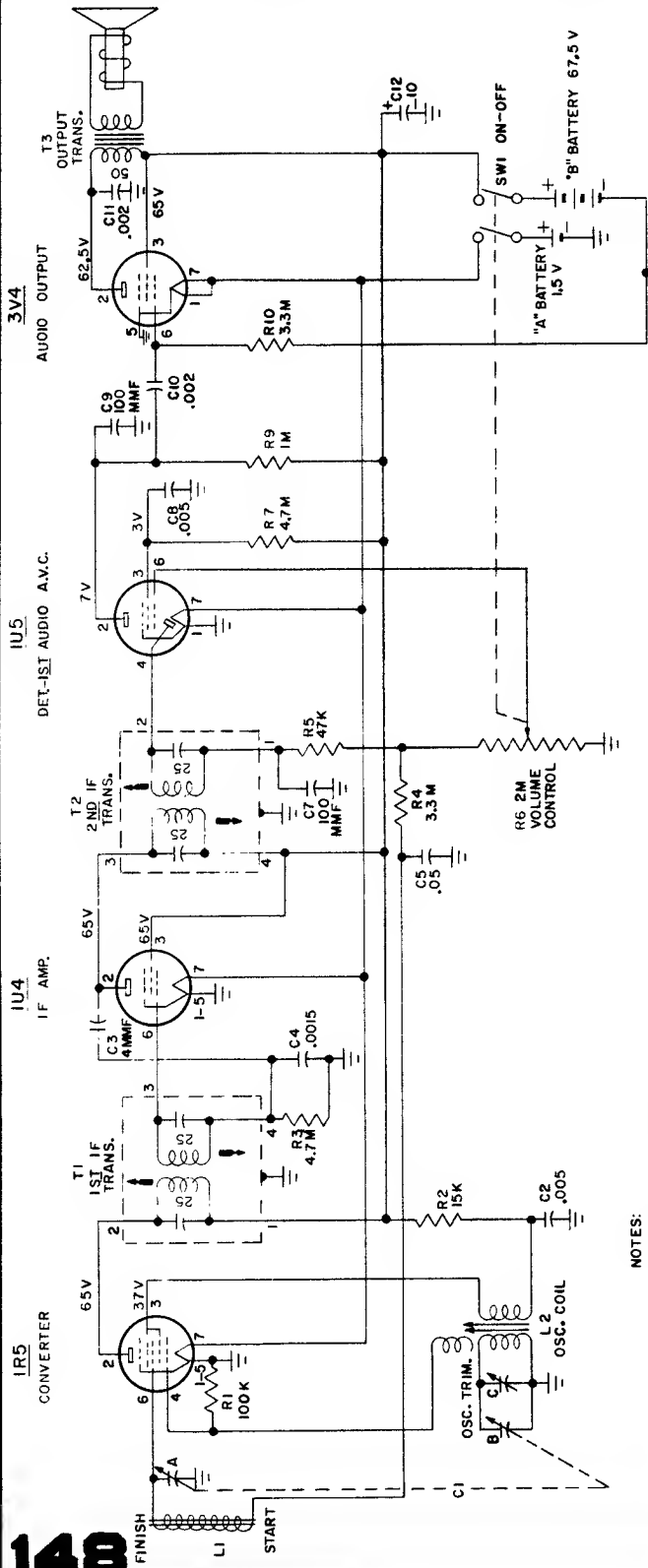

FIG 3 - TOOL REQUIRED FOR IF ALIGNMENT

- NOTES:
1. ALL CAPACITANCE VALUES IN MFD. AND ALL RESISTANCE VALUES IN OHMS UNLESS OTHERWISE SPECIFIED.
 2. ALL VOLTAGES MEASURED FROM CHASSIS (GND.) USING A 20,000 OHM/VOLT METER. VOLTAGES SHOWN ARE BATTERY READINGS AND SHOULD BE ± 20 PER CENT.

ALIGNMENT

Step	Connect Signal Generator to -	Signal Generator Frequency	Radio Dial	Adjust for Maximum Output -
1	Stator of RF section of tuning capacitor C1 through a .01 mfd capacitor.	455 kc.	Minimum capacity	Top and bottom slugs of 2nd and 1st IF transformers in order given. SEE NOTE.
2	Radiated signal	1400 kc.	1400 kc.	Osc. trimmer 'C' (rock-in)
3	Radiated signal	600 kc.	600 kc.	Slug in osc. coil (L2) (rock-in)
4	Repeat steps 2 and 3			

NOTE: An aligning tool with a slender shaft and a hex head is required to align the IF transformers. A suitable tool is illustrated in Fig. 3. The bottom slugs are adjusted from the top of the transformers. To reach the bottom slug, insert the slender shaft end of the aligning tool all the way through the top slug.

MANUAL OF 1954 MOST-OFTEN-NEEDED RADIO DIAGRAMS

Westinghouse

CHASSIS V-2184-2

MODELS H-397T5 AND H-398T5

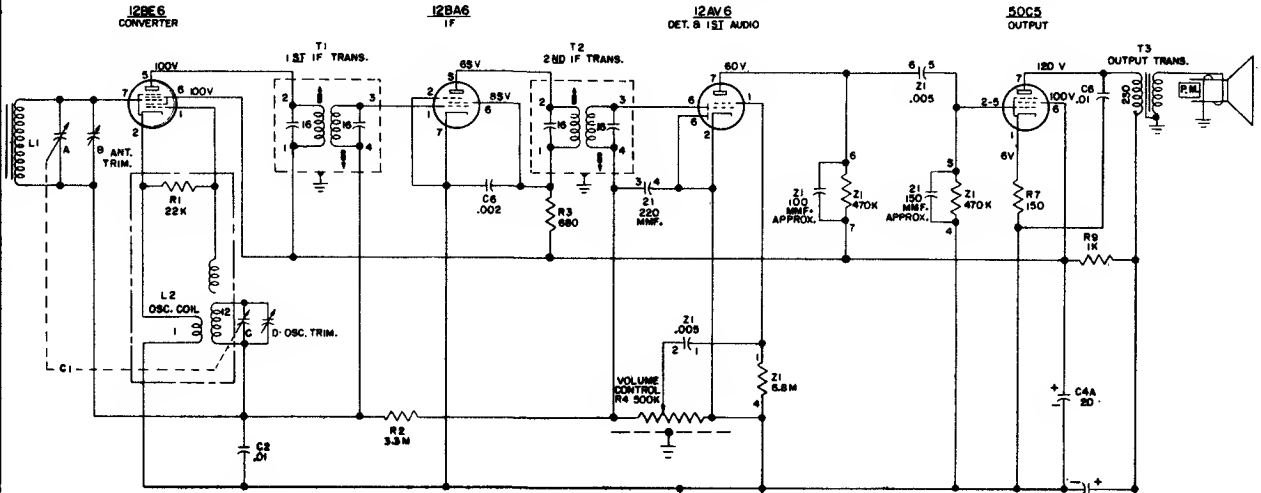

- NOTES:
1. ALL VOLTAGES MEASURED FROM COMMON NEGATIVE USING A 20,000 OHM/VOLT METER. LINE VOLTAGE SET AT 117 V.A.C. READINGS SHOULD BE AS SHOWN $\pm 20\%$.
 2. ALL CAPACITANCE VALUES IN MFD, AND ALL RESISTANCE VALUES IN OHMS UNLESS OTHERWISE SPECIFIED.

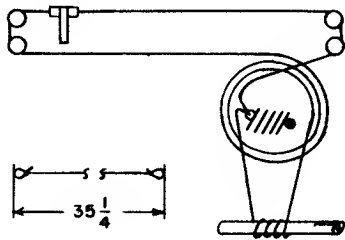

DIAL STRINGING

The contact pins and shields of the tube sockets are replaceable. To replace a contact pin, simply push the pin out through the top of the socket and insert a new pin. To replace a center shield, push it out through the bottom, and insert a new shield.

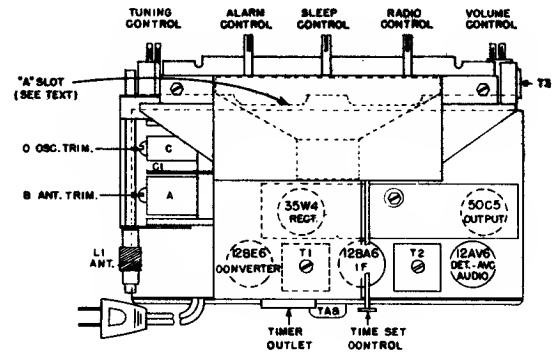
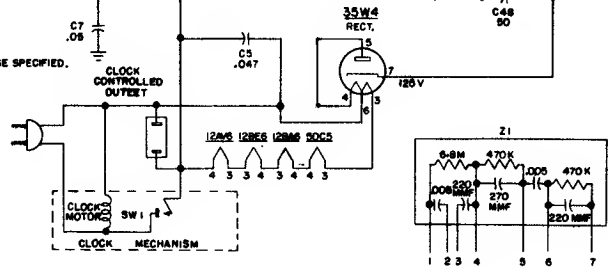

ALIGNMENT

It is recommended that the chassis be isolated from the power line by means of an isolation transformer.

While making the following adjustments, keep the volume control set for maximum output and the signal generator output attenuated to avoid AVC action.

Step	Connect Signal Generator to —	Signal Generator Frequency	Radio Dial	Adjust for Maximum Output —
1	Stator of ant. tuning capacitor (A) through a 200 mfd capacitor	455 kc.	Minimum capacity	Bottom and top slugs of T2 and T1 in order given*
2	Same as step 1	1625 kc.	Minimum capacity	Oscillator trimmer (D)
3	Radiated signal	1400 kc.	1400 kc.	Antenna trimmer (B)

*It is recommended that a fiber aligning tool that snugly fits the slot in the powdered iron core be used to prevent chipping of the slot.

Westinghouse H-409P4

H-410P4 H-411P4

CHASSIS V-2185-1

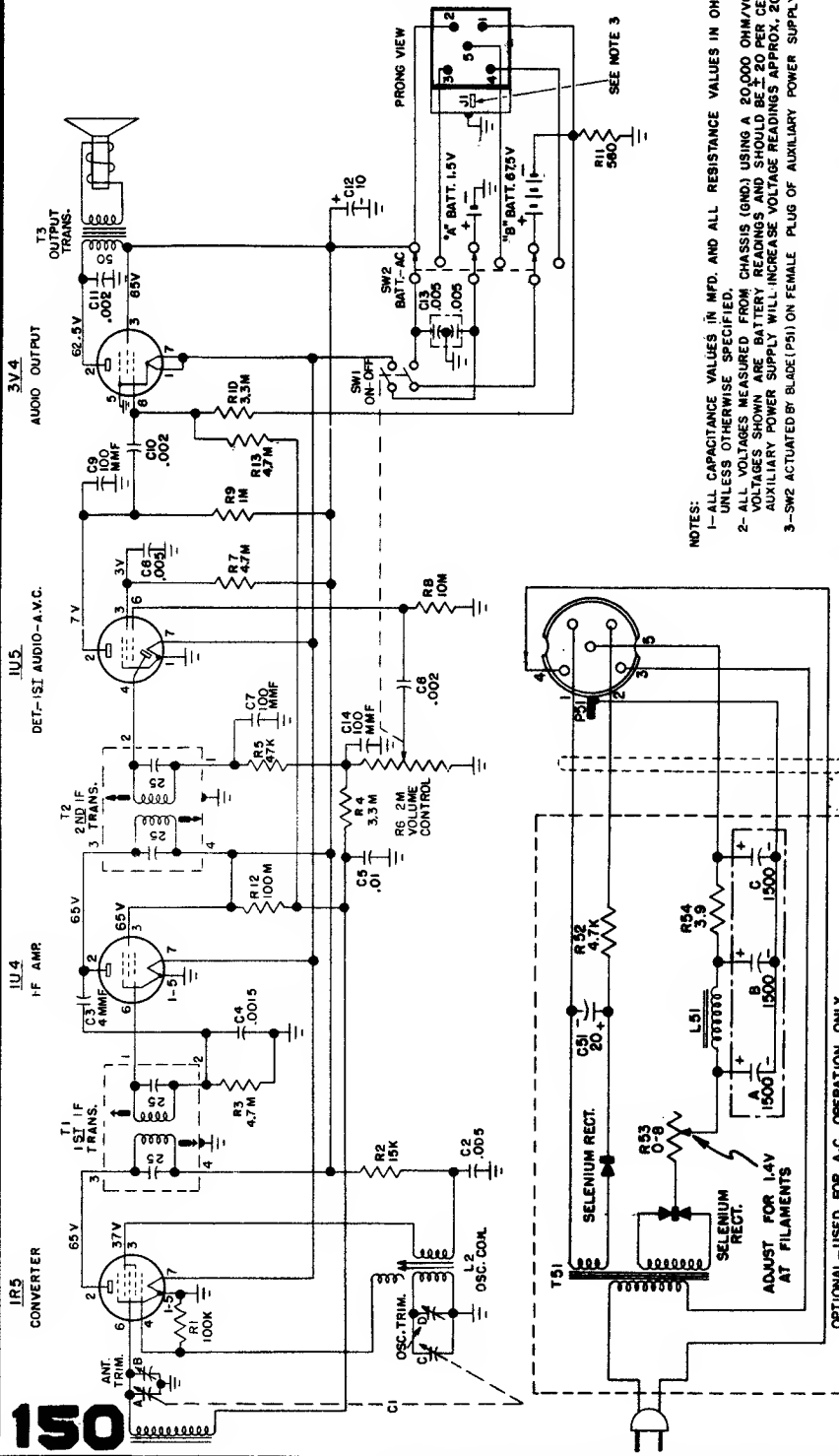

NOTES:
 1—ALL CAPACITANCE VALUES IN MFD. AND ALL RESISTANCE VALUES IN OHMS UNLESS OTHERWISE SPECIFIED.
 2—ALL VOLTAGES MEASURED FROM CHASSIS (GND.) USING A 20,000 OHM/VOLT METER. VOLTAGES SHOWN ARE BATTERY READINGS AND SHOULD BE ± 20 PER CENT. AUXILIARY POWER SUPPLY WILL INCREASE VOLTAGE READINGS APPROX. 20 PER CENT.
 3—SW2 ACTUATED BY BLADE (P51) ON FEMALE PLUG OF AUXILIARY POWER SUPPLY THROUGH J1.

ALIGNMENT H-377

Step	Connect Signal Generator to —	Signal Generator Frequency	Radio Dial	Adjust for Maximum Output —
1	Stator of RF section of tuning capacitor C1 through a .01 mfd capacitor	455 kc.	Minimum capacity	Top and bottom slugs of 2nd and 1st IF transformers in order given. SEE NOTE.
2	Radiated signal	1625 kc.	1625 kc.	Osc. trimmer "D" (rock-in)
3	Radiated signal	1400 kc.	1400 kc.	Ant. trimmer "B"
4	Repeat steps 2 and 3			

NOTE: When adjusting the IF transformers, it is recommended that a fiber aligning tool which snugly fits the slot in the powdered iron core be used to prevent chipping of the slot.

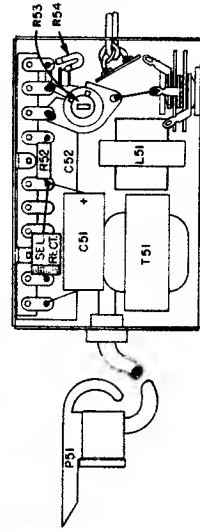

MODEL H-377

AC POWER SUPPLY (OPTIONAL)

MANUAL OF 1954 MOST-OFTEN-NEEDED RADIO DIAGRAMS

Westinghouse H-422P4 H-423P4

H-424P4 H-425P4

CHASSIS V-2188-1

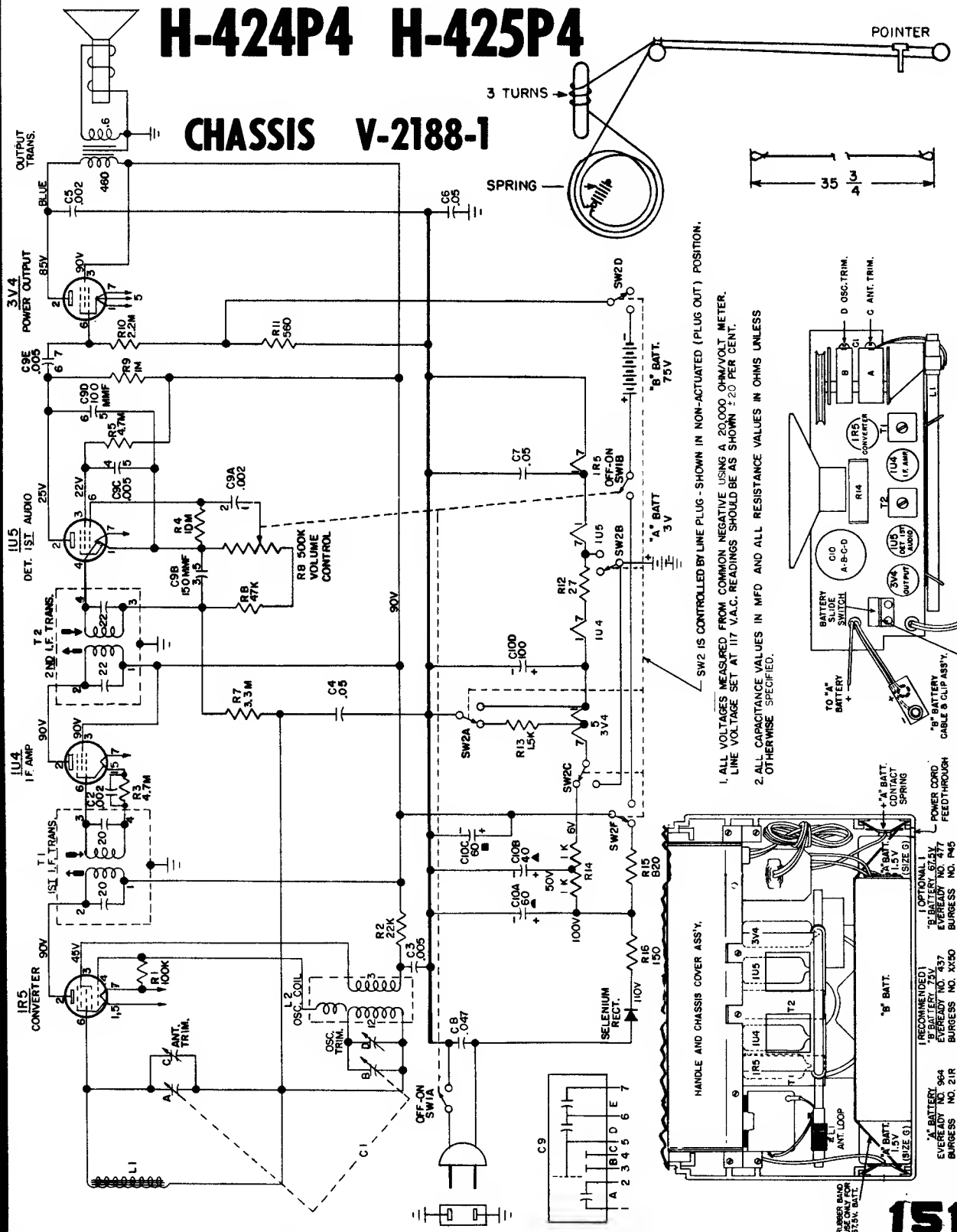

SW2 IS CONTROLLED BY LINE PLUG - SHOWN IN NON-ACTUATED (PLUG OUT) POSITION.

1. ALL VOLTAGES MEASURED FROM COMMON NEGATIVE USING A 20,000 OHM/VOLT METER. LINE VOLTAGE SET AT 117 V.A.C. READINGS SHOULD BE AS SHOWN ± 20 PER CENT.

2. ALL CAPACITANCE VALUES IN MFD AND ALL RESISTANCE VALUES IN OHMS UNLESS OTHERWISE SPECIFIED.

- 1. OPTIONAL
- 2. RECOMMENDED
- 3. 'A' BATTERY 90V
- 4. EVEREADY NO. 964
- 5. BURGESS NO. 21R
- 6. RAY-CHEM. NO. 8R
- 7. 'B' BATTERY 7.5V
- 8. EVEREADY NO. 437
- 9. BURGESS NO. X350
- 10. RAY-CHEM. NO. 8R
- 11. 'C' BATTERY 1.5V (SIZE G)
- 12. 'D' BATTERY 1.5V (SIZE G)
- 13. POWER CORD
- 14. FEEDTHROUGH
- 15. ANT. LOOP
- 16. ANT. TRIM.
- 17. 'A' BATTERY CONTACT SPRING
- 18. 'B' BATTERY CONTACT SPRING
- 19. 'C' BATTERY CONTACT SPRING
- 20. 'D' BATTERY CONTACT SPRING
- 21. 'A' ANT. TRIM.
- 22. 'B' ANT. TRIM.
- 23. 'C' ANT. TRIM.
- 24. 'D' ANT. TRIM.

MANUAL OF 1954 MOST-OFTEN-NEEDED MODELS H-417T5 H-418T5

Westinghouse

CHASSIS V-2186-1

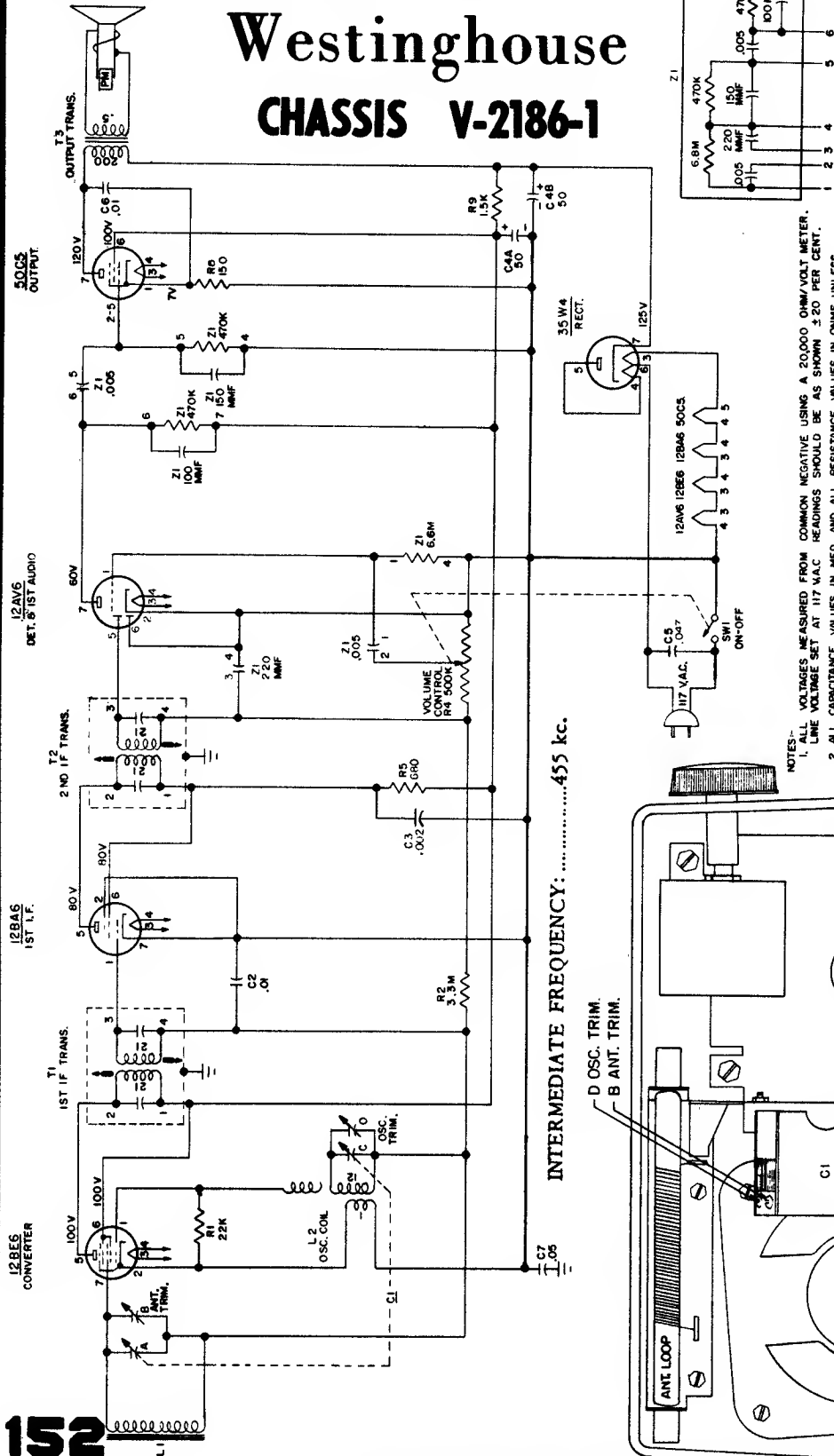

INTERMEDIATE FREQUENCY:455 kc.

D OSC. TRIM.

B ANT. TRIM.

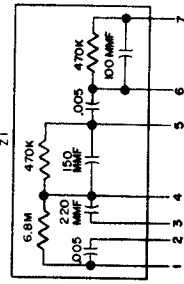

NOTES:-
 1. ALL VOLTAGES MEASURED FROM COMMON NEGATIVE USING A 20,000 OHM/VOLT METER.
 LINE VOLTAGE SET AT 117 VAC. READINGS SHOULD BE AS SHOWN ± 20 PER CENT.
 2. ALL CAPACITANCE VALUES IN MFD. AND ALL RESISTANCE VALUES IN OHMS UNLESS OTHERWISE SPECIFIED.

Step	Connect Signal Generator to -	Signal Generator Frequency	Radio Dial	Adjust for Maximum Output -
1	Stator of ant. tuning capacitor (A) through a 200 mmf capacitor	455 kc.	Minimum capacity	Bottom and top slugs of T2 and T1 in order given
2	Same as step 1	1625 kc.	Minimum capacity	Oscillator trimmer (D)
3	Radiated signal	1400 kc.	1400 kc.	Antenna trimmer (B)
4	Repeat steps 2 and 3			

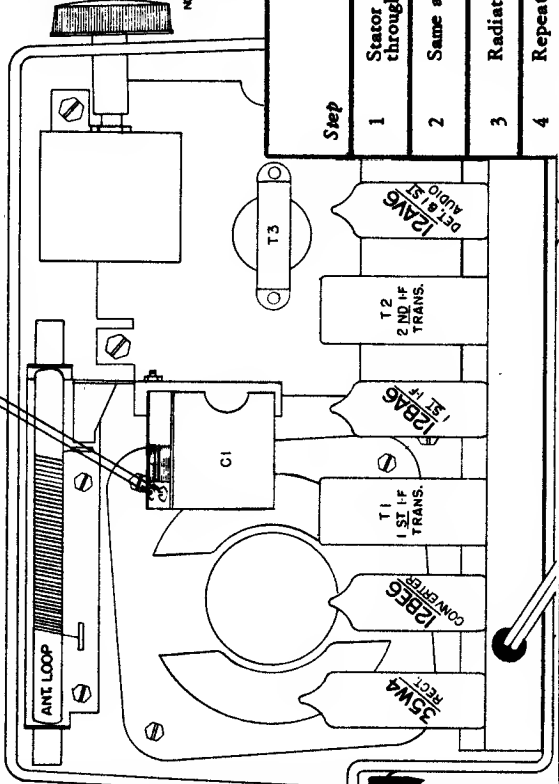

MANUAL OF 1954 MOST-OFTEN-NEEDED RADIO DIAGRAMS

ZENITH RADIO CORPORATION

MODELS HF14, HF14E, HF15R & HF15E

CHASSIS 3M02

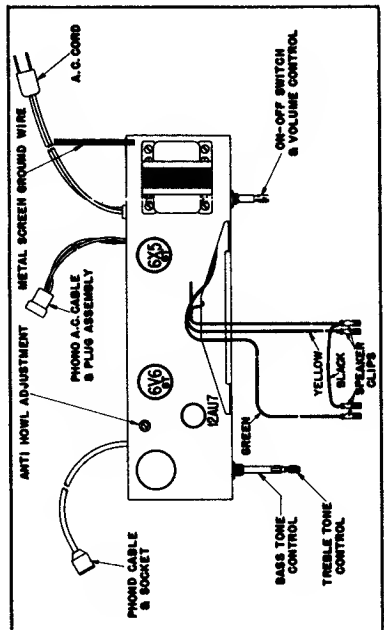
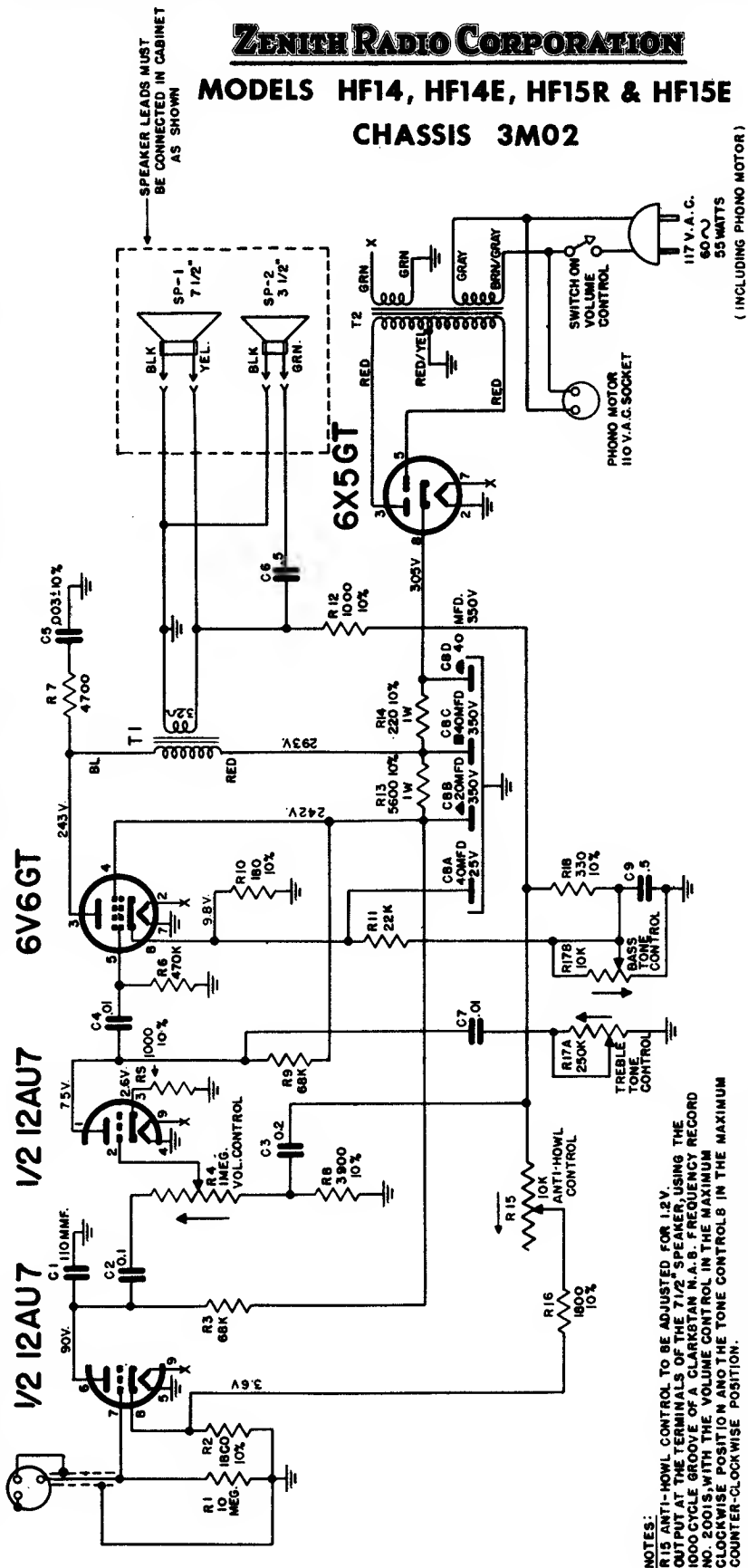

NOTES:
 R15 ANTI-HOWL CONTROL TO BE ADJUSTED FOR 1.2V. OUTPUT AT THE TERMINALS OF THE 7 1/2" SPEAKER, USING THE 1000 CYCLE GROOVE OF A CLARKSTAN N.A.B. FREQUENCY RECORD NO. 2001S, WITH THE VOLUME CONTROL IN THE MAXIMUM COUNTER-CLOCKWISE POSITION AND THE TONE CONTROL IN THE MAXIMUM COUNTER-CLOCKWISE POSITION.
 ARROW INDICATES CLOCKWISE ROTATION.
 ALL RESISTORS ARE ±20% TOLERANCE UNLESS OTHERWISE SPECIFIED. ALL VOLTAGES ARE D.C. UNLESS OTHERWISE SPECIFIED AND ARE MEASURED FROM POINTS INDICATED TO CHASSIS WITH AN A.C. VACUUM TUBE VOLTMETER WITH ANTI-HOWL CONTROL IN THE MAXIMUM CLOCKWISE POSITION.

REF. NO.	DESCRIPTION	DESIGNATES CHASSIS
CHASSIS PARTS		
C7	Line Cord	
C1	Socket Shell (part of S-20584)	
C5	.01 Mfd. Ceramic Disc	10% (2 used)
C2	500V	10% (2 used)
C3	110 Mmf. Ceramic Disc	10%
C4	600V	20%
C6, C9	200V	20%
C8, B, C, D	.1 Mfd.	10%
	.5 Mfd.	10%
	120V (2 used)	10%
	Electrolytic	
R18	330 Ohm	10%
R5, R12	1 K Ohm	10%
R2, R16	1.8 K Ohm	10%
R8	3.9 K Ohm	10%
R7	4.7 K Ohm	20%
R11	22 K Ohm	20%
R3, R9	68 K Ohm	20%
R6	470 K Ohm	20%
R1	10 Megohm	20%
R10	180 Ohm	10%
R15	Feed-Back Control	
R17A, B	Bass & Treble Tone Control	
R4	Volume Control & Switch	
R14	220 Ohm	10%
R13	5.6 Ohm	10%

MANUAL OF 1954 MOST-OFTEN-NEEDED RADIO DIAGRAMS

ZENITH RADIO CORPORATION

MODEL S-9011 and S-9012
CHASSIS 3L01

REF. NO.	DESCRIPTION		
C1, 2, 3, 6, 12	.01 Mfd Ceramic	500V (5 used)	
C8	470 Mmfd Ceramic disc.	500V	
C9	.006 Mfd	600V	
C5	.1 Mfd	400V	
C7	.001 Mfd Molded	600V	
C4	.002 Mfd	200V	
C11	.01 Mfd	400V	
C10A, B, C, D	Electrolytic 60 x 40 x 20 - 150V x 20 - 25V		
R10	150 ohm	1/2 W W	10% Ins.
R13	150 ohm	1/2 W	10% Ins.
R3	22 ohm	1/2 W W	10% Ins.
R12	1200 ohm	1/2 W	10% Ins.
R11	1500 ohm	1/2 W	10% Ins.
R8	6800 ohm	1/2 W	10% Ins.
R7	22K ohm	1/2 W	10% Ins.
R3	68K ohm	1/2 W	10% Ins.
R5	120K ohm	1/2 W	10% Ins.
R7	1 Meg ohm	1/2 W	10% Ins.
R2	3.3 Meg ohm	1/2 W	10% Ins.
R1	4.7 Meg ohm	1/2 W	10% Ins.
R14	150 ohm	5 W W	10% Ins.

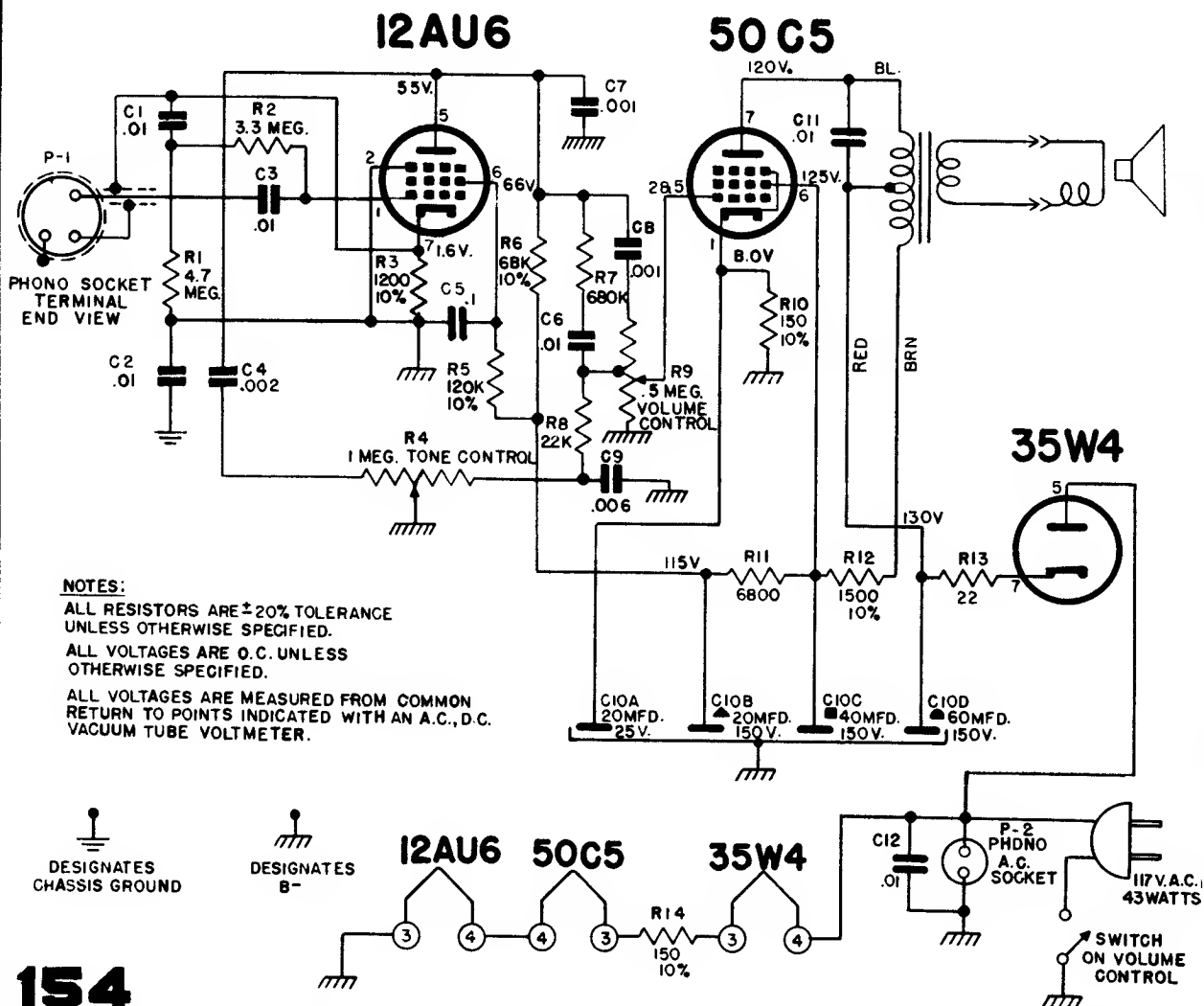
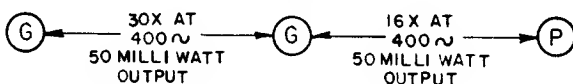
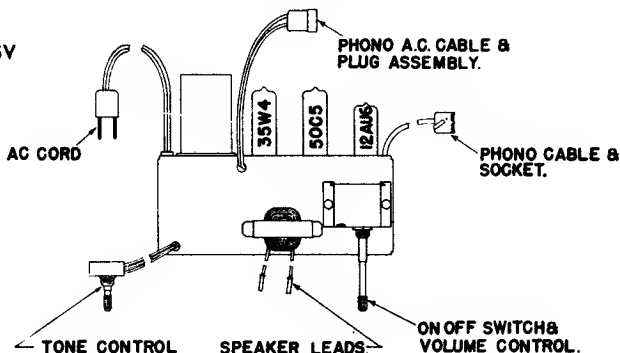

NOTES:

ALL RESISTORS ARE $\pm 20\%$ TOLERANCE UNLESS OTHERWISE SPECIFIED.
ALL VOLTAGES ARE O.C. UNLESS OTHERWISE SPECIFIED.
ALL VOLTAGES ARE MEASURED FROM COMMON RETURN TO POINTS INDICATED WITH AN A.C., D.C. VACUUM TUBE VOLTMETER.

DESIGNATES CHASSIS GROUND

DESIGNATES B-

MANUAL OF 1954 MOST-OFTEN-NEEDED RADIO DIAGRAMS

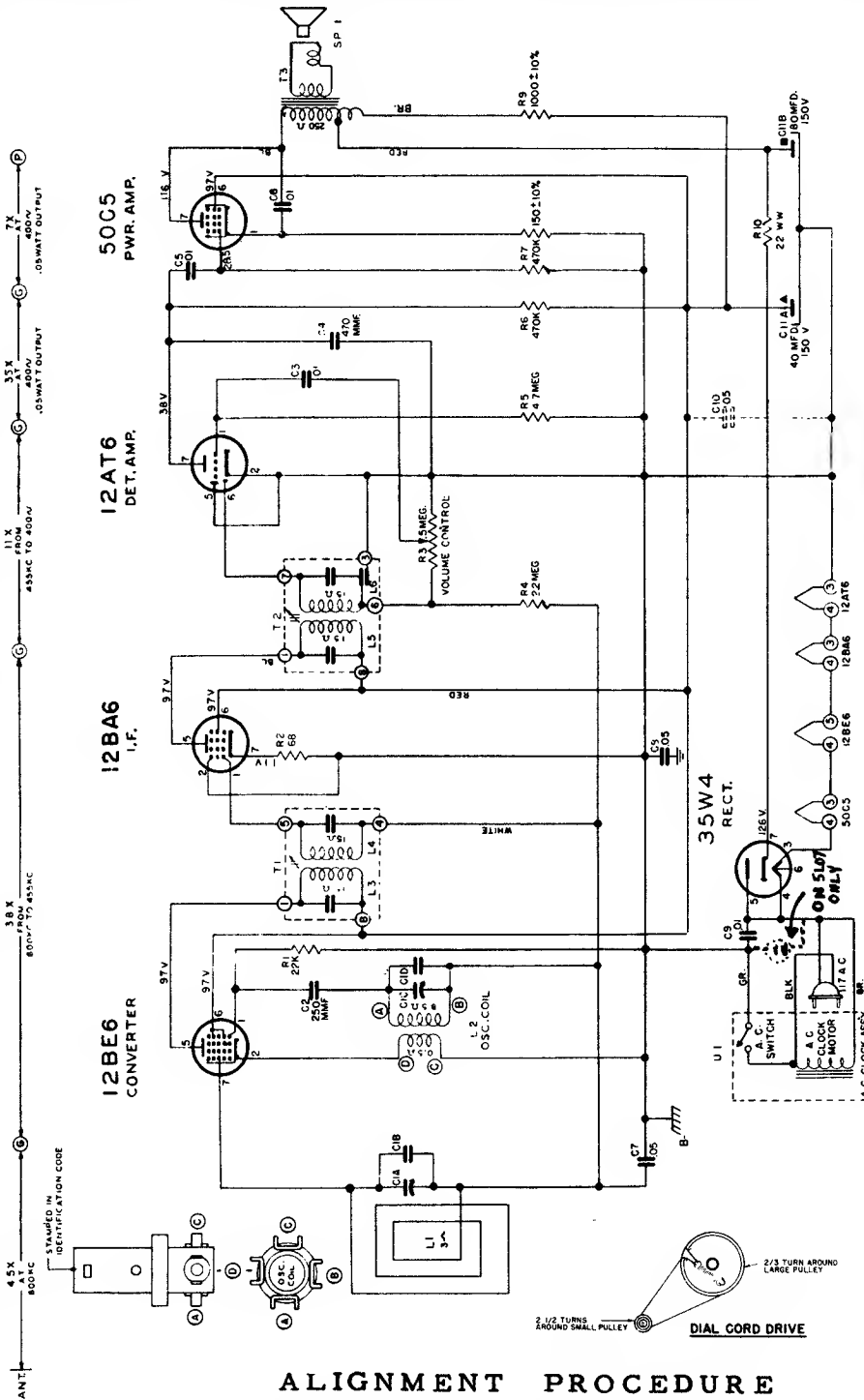

IF TRANSFORMER NUMBERING STARTS WITH #1 TERMINAL NEAR NON-INDUCTIVE ELECTROLYTIC CAPACITOR. IF OTHER TYPE OF ELECTROLYTIC IS USED, IT WILL BE NECESSARY TO ADD C.O. SHOWN IN DOTTED LINES.

I.F. FREQUENCY 455KC.

TUNING RANGE 535-1620MC

ALL VOLTAGES MEASURED FROM COMMON UNLESS OTHERWISE SPECIFIED

ALL RESISTORS 1% TOLERANCE UNLESS OTHERWISE SPECIFIED

1.5 C. 5-1000K 455K

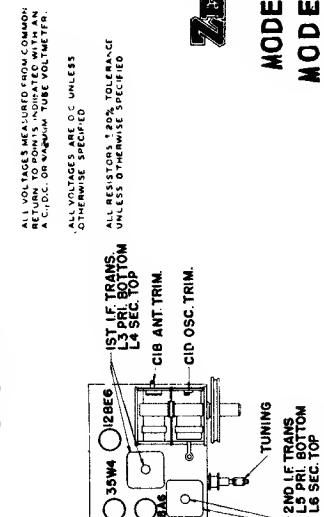

ALIGNMENT PROCEDURE

OPERATION	CONNECT OSCILLATOR TO	DUMMY ANTENNA	INPUT SIG. FREQUENCY	SET DIAL AT	TRIMMERS	PURPOSE
1	Converter Grid	.5 Mfd.	455 Kc.	600 Kc.	L 3,4,5,6	For I.F. Alignment
2	One Turn Loop Coupled Loosely to Wave Magnet	---	1600 Kc.	1600 Kc.	CID	Set Oscillator to Dial Scale
3		---	1400 Kc.	1400 Kc.	CIB	Align Antenna Stage

ZENITH RADIO CORPORATION

MODEL L515
MODEL L520

CHASSIS 5L06
CHASSIS 5L07

MANUAL OF 1954 MOST-OFTEN-NEEDED RADIO DIAGRAMS

ZENITH RADIO CORPORATION

CHASSIS 4LO3 USED ON MODEL L2281

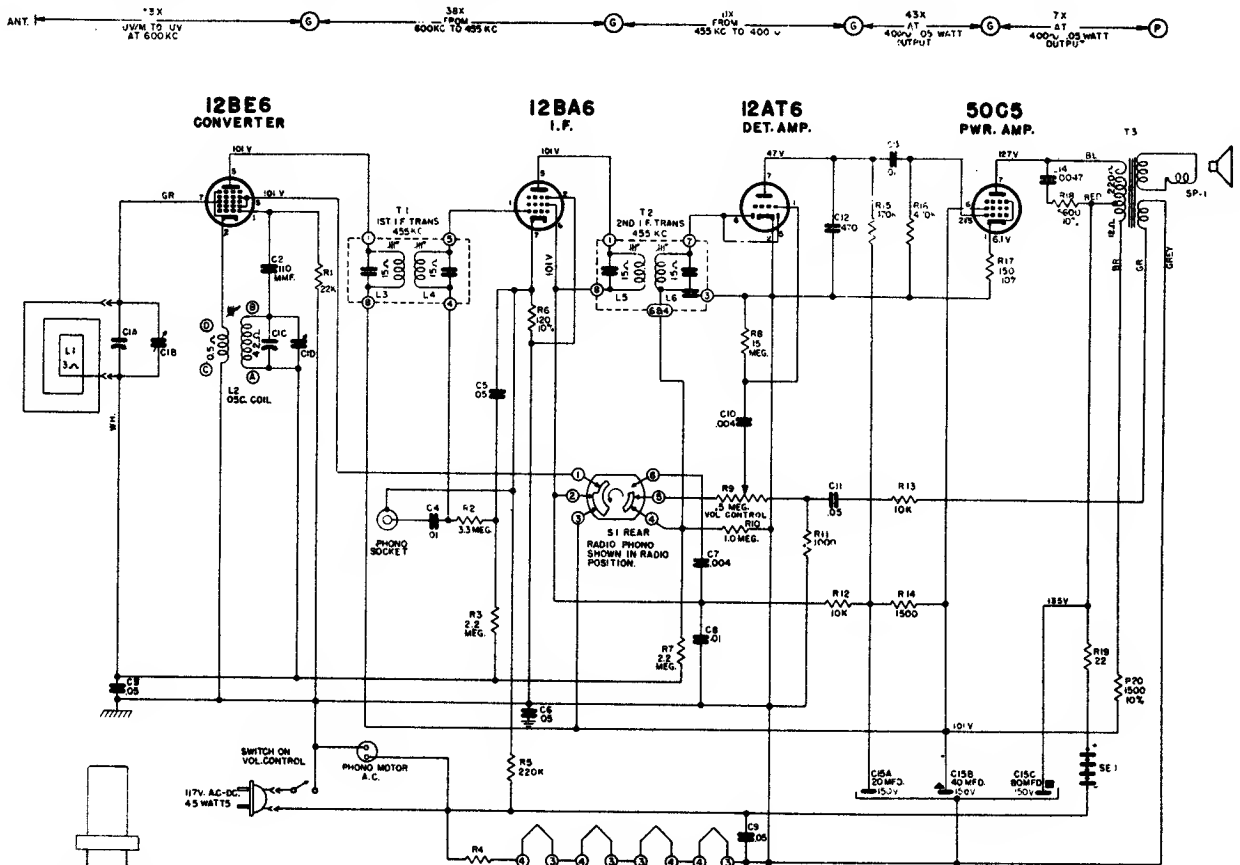

NOTES
 ALL VOLTAGES MEASURED FROM COMMON RETURN TO POINTS INDICATED WITH AN A.C. D.C. OR VACUUM TUBE VOLT METER.
 ALL VOLTAGES ARE D.C. UNLESS OTHERWISE SPECIFIED.
 ALL RESISTORS 1% TOLERANCE UNLESS OTHERWISE SPECIFIED.
 USE ONLY ZENITH NON-INDUCTIVE ELECTROLYTIC CONDENSERS FOR REPLACEMENT.

⊥ DENOTES CHASSIS

⊥ DENOTES COMMON RETURN B-

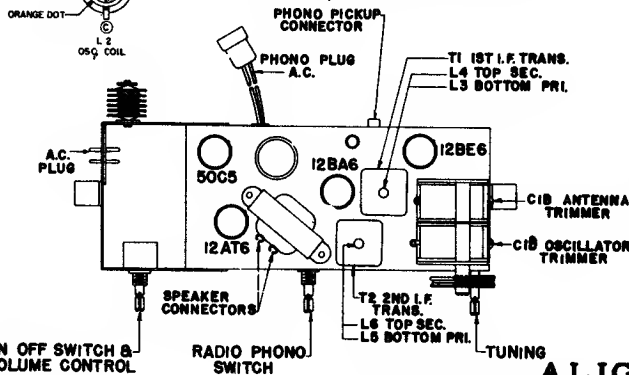

The I.F. transformers incorporated in this receiver are of the new permeability tuned type. The advantage of an I.F. transformer of this type is its extreme stability under various humidity and temperature conditions. The upper coil is the secondary and the lower the primary. When adjusting these I.F. transformers the tuning wrench 68-19 can be inserted into the top slug, rotated until maximum output is obtained and then dropped down to the lower slug and the same operation repeated. The tuning wrench is so designed that turning one slug does not affect the adjustment of the other.

ALIGNMENT PROCEDURE

OPERATION	CONNECT OSCILLATOR TO	DUMMY ANTENNA	INPUT SIG. FREQUENCY	SET DIAL AT	TRIMMERS	PURPOSE
1	Converter Grid	.5 Mfd.	455 Kc.	600 Kc.	3, 4, 5, 6	For I.F. Alignment
2	Single Turn Loosely Coupled to Wave Magnet	--	1620 Kc.	1620 Kc.	C1D	Set Oscillator to Dial Scale.
3		--	1400 Kc.	1400 Kc.	C1B	Antenna Alignment

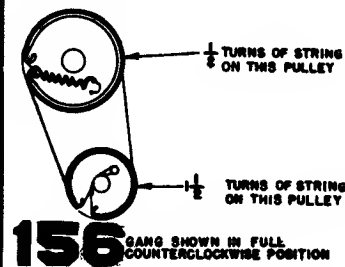

156

GANG SHOWN IN FULL COUNTERCLOCKWISE POSITION

MANUAL OF 1954 MOST-OFTEN-NEEDED RADIO DIAGRAMS



Models L565E and L565R, Chassis 5L09
Model L566, Chassis 5L08, is similar.

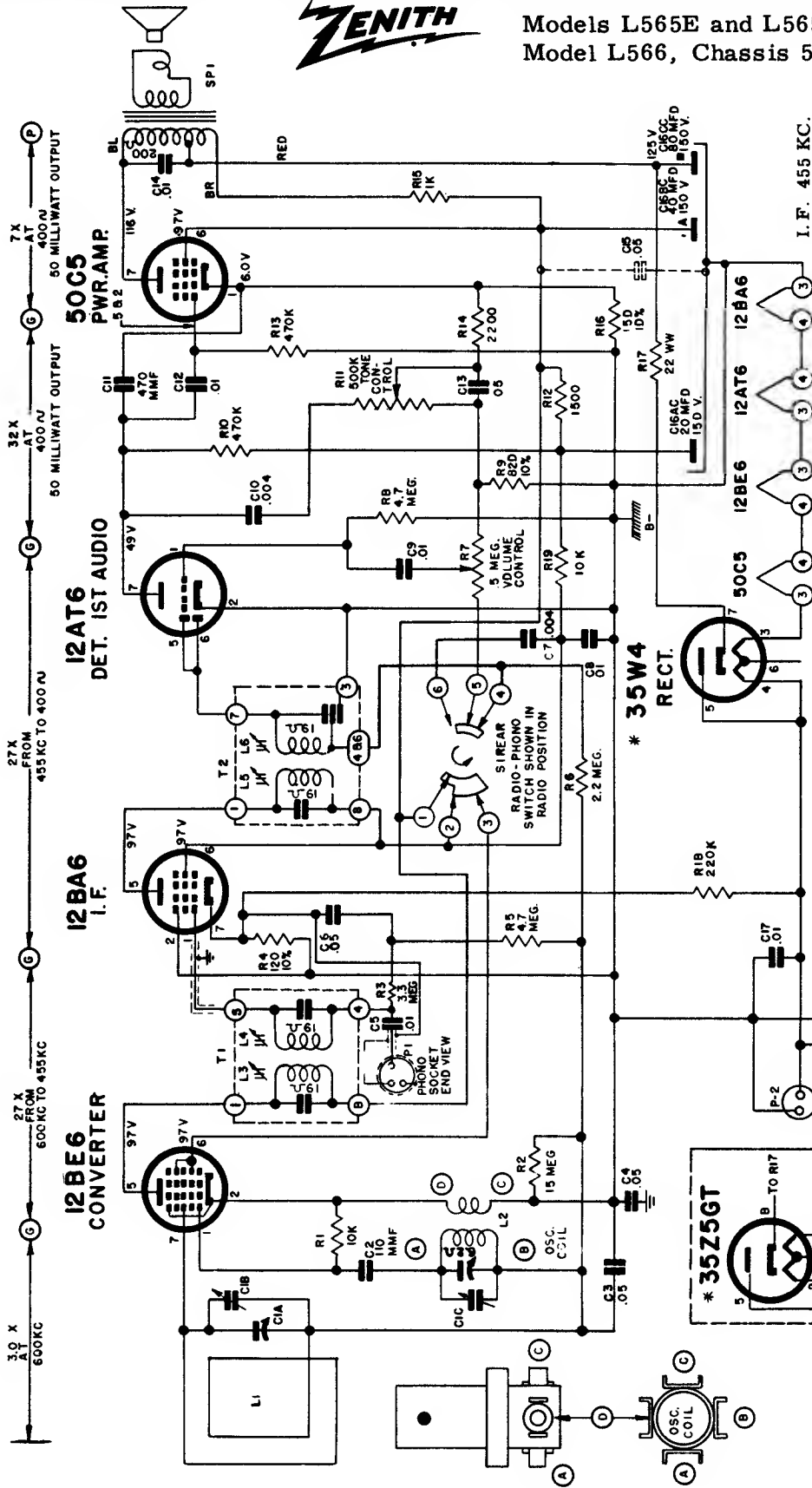

NOTES:
ALL VOLTAGES MEASURED FROM COMMON RETURN TO POINTS INDICATED WITH A D.C. VACUUM TUBE VOLTMETER & THE SET OPERATING ON 117 V.A.C.
ALL VOLTAGES ARE D.C. UNLESS OTHERWISE SPECIFIED
ALL RESISTORS ± 20% TOLERANCE UNLESS OTHERWISE SPECIFIED.
USE ONLY ZENITH NON-INDUCTIVE ELECTROLYTIC CONDENSER FOR REPLACEMENT.
IF ANY OTHER TYPE OF ELECTROLYTIC IS USED IT WILL BE NECESSARY TO ADD PARTS SHOWN IN DOTTED LINES.
I.F. TRANSFORMER NUMBERING STARTS WITH #1 TERMINAL CLOCKWISE AND ADJACENT TO MARKER AS VIEWED FROM BOTTOM OF CHASSIS

117 V.A.C.
40 WATTS
I.F. FREQUENCY 455 KC
TUNING RANGE 535-1620KC

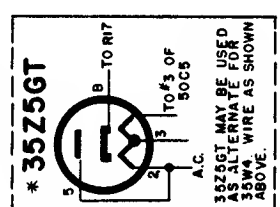

⊕
DENOTES CHASSIS

DENOTES B-

MANUAL OF 1954 MOST-OFTEN-NEEDED RADIO DIAGRAMS

ZENITH RADIO MODELS M510R, Y, G & W CHASSIS 5M02

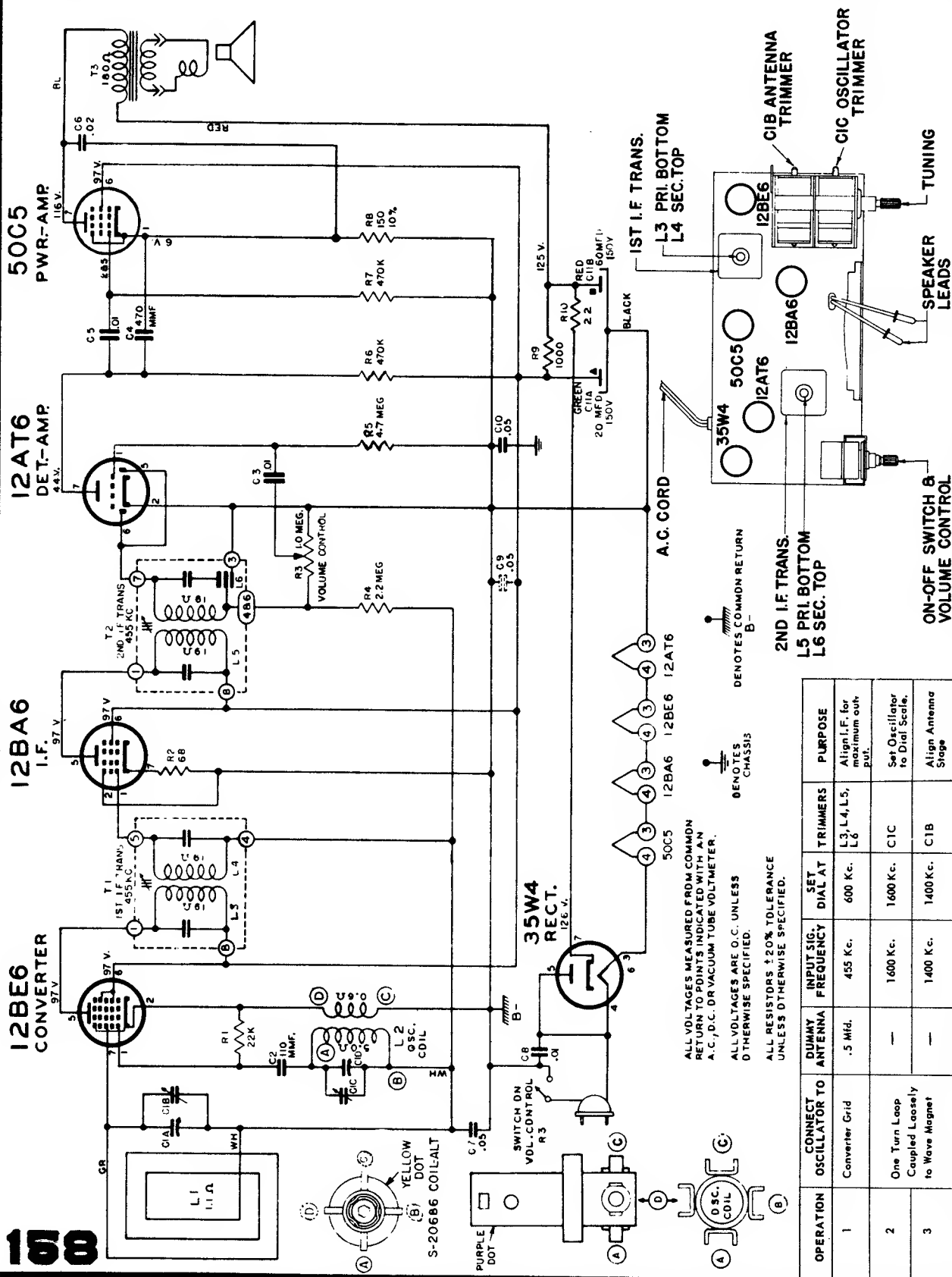

OPERATION	CONNECT TO OSCILLATOR TO	DUMMY ANTENNA	INPUT SIG. FREQUENCY	SET DIAL AT	TRIMMERS	PURPOSE
1	Converter Grid	.5 Mfd.	455 Kc.	600 Kc.	L3, L4, L5, L6, L7, L8, L9	Align I.F. for maximum out. put.
2	One Turn Loop Coupled Loosely to Wave Magnet	—	1600 Kc.	1600 Kc.	C1C	Set Oscillator to Dial Scale.
3	—	—	1400 Kc.	1400 Kc.	C1B	Align Antenna Stage.

MANUAL OF 1954 MOST-OFTEN-NEEDED RADIO DIAGRAMS

ZENITH RADIO CORPORATION

MODELS L677R & L677E

CHASSIS 6L20

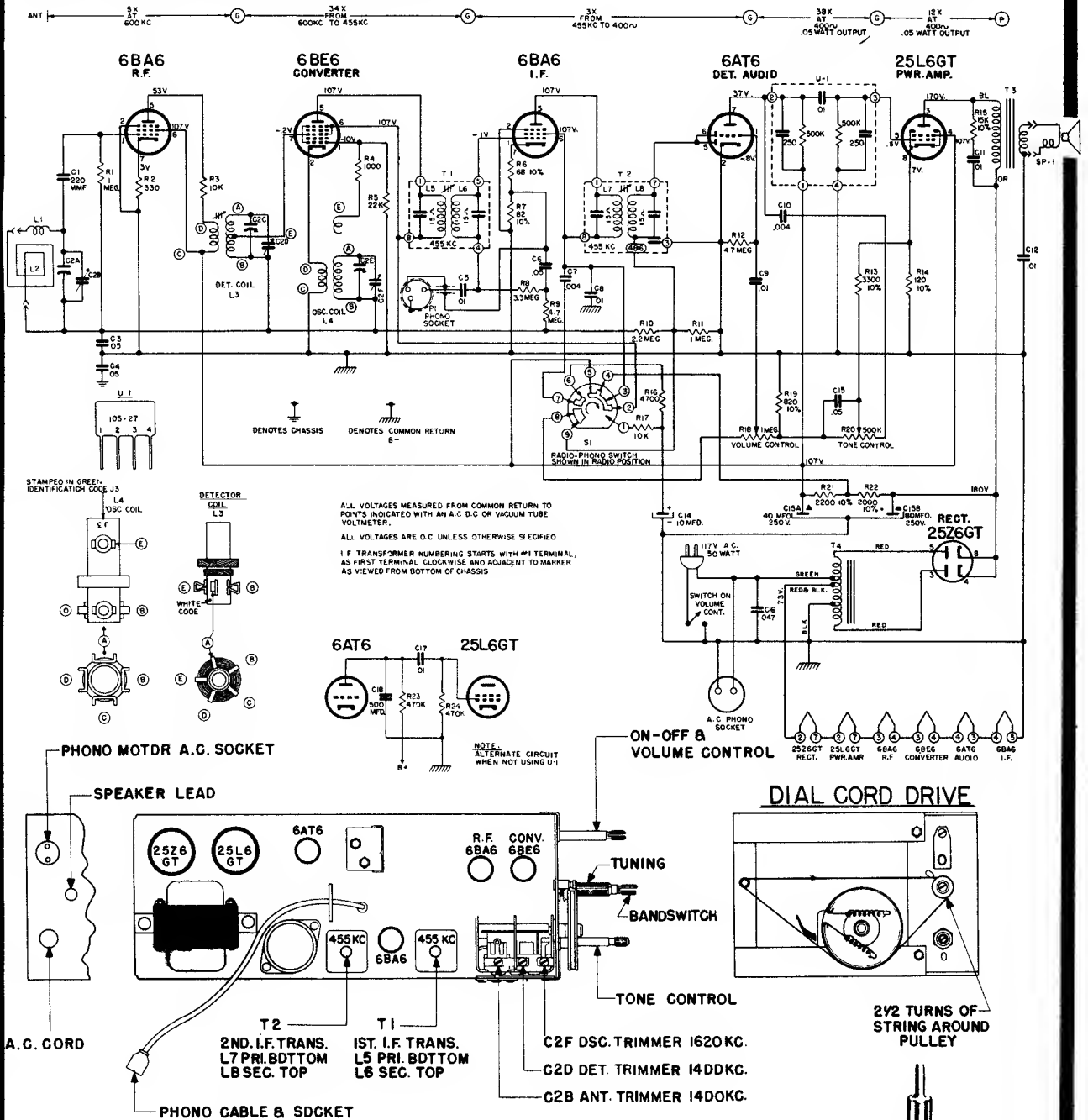

ALIGNMENT PROCEDURE

OPERATION	CONNECT OSCILLATOR TO	DUMMY ANTENNA	INPUT SIG. FREQUENCY	SET DIAL AT	TRIMMERS	PURPOSE
1	Converter Grid	.5 Mfd.	455 Kc.	600 Kc.	L 5, 6, 7, 8	For I.F. Alignment
2	Single Turn Loosely Coupled to Wave Magnet	--	1620 Kc.	1620 Kc.	C 2 F	Set Oscillator to Dial Scale.
3		--	1400 Kc.	1400 Kc.	C 2 D	Detector Alignment
4		--	1400 Kc.	1400 Kc.	C 2 B	Antenna Alignment

MANUAL OF 1954 MOST-OFTEN-NEEDED RADIO DIAGRAMS

ZENITH RADIO CORPORATION

Models L1083E - L1086R

Chassis 10L20

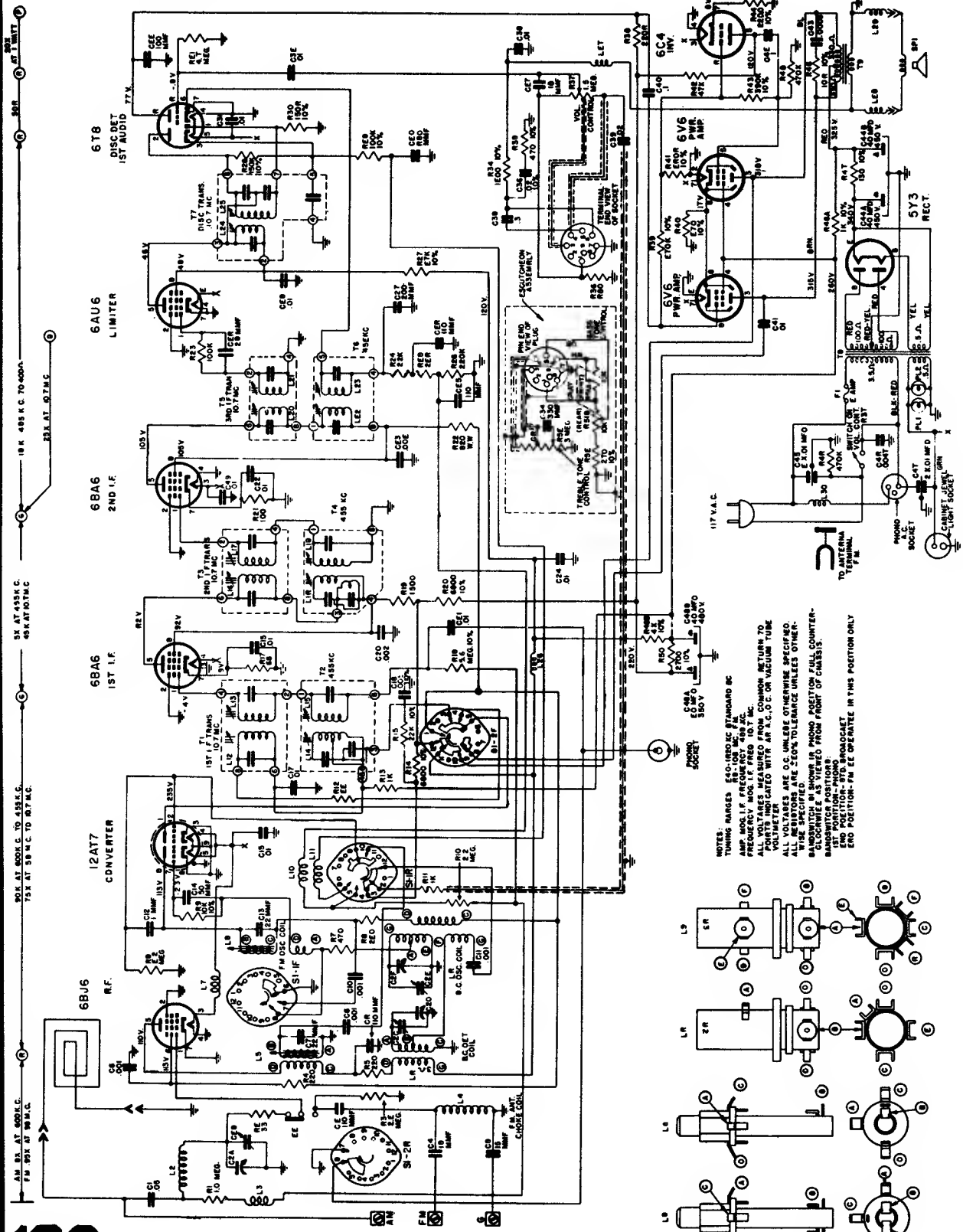

AM 83 AT 600 K.C.
 FM 193 AT 93.5 K.C.
 60 K AT 600 K.C. TO 435 K.C.
 75 X AT 50 K.C. TO 87 K.C.
 5K AT 435 K.C.
 45 X AT 107 K.C.
 18 K 485 K.C. TO 400 K.
 23 X AT 40.7 K.C.
 20 K AT 17.7 K.C.
 20 K AT 17.7 K.C.

NOTES:
 TUNING RANGES 540-1600 KC. STANDARD BC
 AMP. MOD. I.F. FREQUENCY 107 K.C.
 ALL VOLTAGES MEASURED FROM COMMON RETURN TO
 VOLTMETER UNLESS OTHERWISE SPECIFIED.
 ALL VOLTAGES ARE O.C. UNLESS OTHERWISE SPECIFIED.
 BANDWIDTHS AS SHOWN IN PHONO POSITION FULL COUNTER-
 POINT POSITION—PHONO POSITION—PHONO POSITION
 END POSITION—FM EE OPERATE IN THIS POSITION ONLY

